

VERSALINE LC



Versaline LC

The Versaline L.C. is a "lower cost" version of the popular Versaline pressure sensitive labeling system. It combines robust construction and design efficiency to set a new price/performance standard. Configurations include front/back, wrap, 3 panel or custom at speeds up to 300 ppm with +/-1/32" accuracy.

The M3 microprocessor features "flash" memory. This replaces 'prom chip' technology and allows programming upgrades by email. The M3 also includes 'self teach' for instant set-up and changeover.

Component choices include servo or stepping motor label drive, dual feed screws, chain aligners, orienting devices, powered impressers, bar code scanners, vision systems, eject station, ect.

Versaline's **quality** surpasses all equipment in its price range, making it suitable for multishift operations where long term reliability is important.

Versaline's **flexibility** is ideal for contract packagers or *any* company requiring frequent changeovers on a wide variety of products.



7670 Jenther Drive, Mentor, Ohio 44060
440-602-4700 Fax: 440-602-4701 E-Mail: labeling@quadrel.com

Packaging - Processing

Bid on Equipment

1-847-683-7720

www.bid-on-equipment.com

CAPABILITIES PROFILE

SPECIFICATIONS

VERSALINE SYSTEM

Speed: Up to 300 products per minute (dependent upon label/product dimensions)

Applied Accuracy: Up to +/- 1/32" (1mm) @ Sigma 2

Maximum Product Height: 14" (356mm)*

Minimum Product/Label Dimensions: Consult factory

Overall System Length: 120" (3.05m) standard*

Standard Width: (Single Head) 48" (1.2m)
(Dual Head) 72.25" (1.7m)

Utilities: 220/208VAC/Single Phase/60Hz

Approximate Net Shipping Weight: 1500 lbs. (682kg)
(dependent upon system configuration)

*CONSULT FACTORY FOR CUSTOM CAPABILITIES

PRODUCT HANDLING

- Variable speed D.C.
- Optional A.C. frequency inverter control
- 4-1/2" width x 120" length conveyor
- Feedscrew drive or chain aligners for product alignment
- Wrap station for round containers available in 12", 18" or 24" length

OPTIONS

- Recommended spare parts kit
- Right or left-hand versions
- Low label detection
- End of web detection
- Broken web detection
- Hot Stamp Imprinter
- Clear label sensor
- Missing label on product detection
- Missing imprint detection on label
- Loose loop thermal transfer printers

Q60C LABELING HEAD

Accuracy: Up to +/-1/32" (1mm)

Dispensing Speed: Variable, up to 1200"(30m) per minute: 2200" per minute drive also available

Label Drive: Digital stepping motor standard
Optional Closed loop servo

Design Features: Outboard supported label drive
Stainless steel/aluminum construction
Precision sealed bearing

Label Dimensions:

Maximum width = 4 3/8" (114mm), optional 6 7/8"(174mm), 9 7/8" (254mm)

Maximum length = required length

Minimum width 1/2" (13mm)

Minimum length = 1/2" (13mm)

Roll Capacity: 16" (406mm) O.D. on 3" (76mm) I.D. core

Web Width: Overall 4 1/2"(114mm), optional 7" and 10"

Label Format: Die cut, waste removed (minimum 1/8" [3mm] between labels)

Label Sensing: Photoelectric

Utilities: 220v AC, 50/60Hz, 10amps@

M3.0 MICROPROCESSOR CONTROL

- Flash memory, computer programmable
- Self teach feature: instant setup and changeover
- Password protected
- Display in English or Metric units
- Onboard Diagnostics
- Product counter, label counter, elapsed hour meter, dispense speed and product per minute display
- Soft-touch keypad
- Rate compensation synchronizes label to changing line speeds

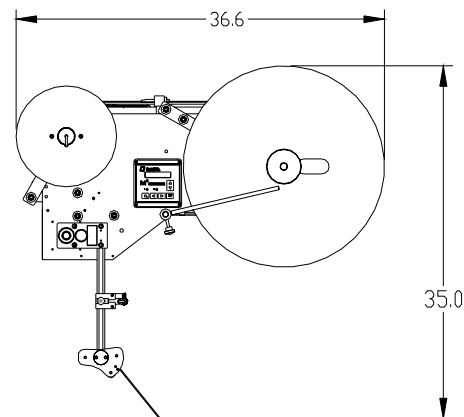
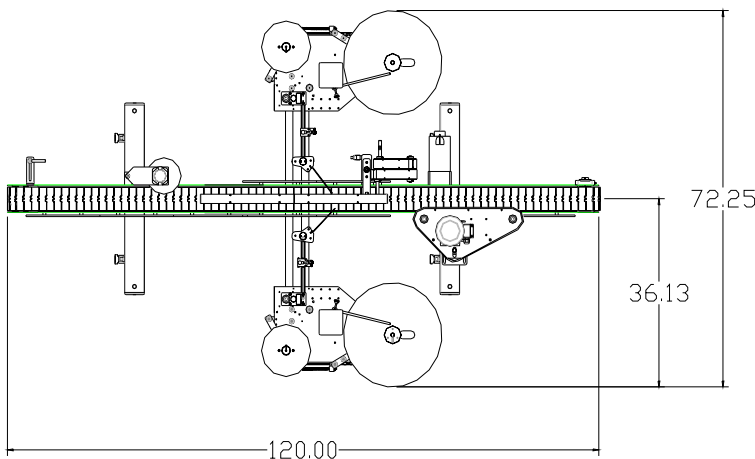

QUADREL
LABELING SYSTEMS

7670 Jenther Drive, Mentor, Ohio 44060

440-602-4700 Fax: 440-602-4701 E-Mail: labeling@quadrel.com

Packaging - Processing

Bid on Equipment

1-847-683-7720

www.bid-on-equipment.com