

CAPABILITIES PROFILE

Q55 LABEL APPLICATOR



SIMPLE, RUGGED, RELIABLE

The Q55 is a new, compact, heavy duty applicator capable of speeds to 1000" per minute with +/-1/32" accuracy. This applicator features stepper driven label feed and built-in microprocessor control. The compact size, rugged design, and intuitive operation make the Q55 the most versatile and reliable applicator in its class.

The Q55 is a simplified version of Quadrel's high performance Q60 applicator, an industry standard for more than 20 years. In fact, much of the Q55 is interchangeable with the Q60.

The Q55 may be used as a stand alone applicator or integrated into the ModuLine or VersaLine Labeling Systems.

ADVANCED CONTROLS

The user friendly M3 microprocessor features 'self teach' set up, allowing for one button product setups and instant changeover with the capacity to retain 50 label formats. In addition, the M3 features on-board diagnostics for fault conditions and 'soft touch' operator interface.



QUADREL
LABELING SYSTEMS

7670 Jenther Drive, Mentor, Ohio 44060
440-602-4700 Fax: 440-602-4701 E-Mail: labeling@quadrel.com

Packaging - Processing

Bid on Equipment

1-847-683-7720

www.bid-on-equipment.com

CAPABILITIES PROFILE

M3.0 MICROPROCESSOR CONTROL

Flash memory, computer programmable
Self teach feature: instant setup and changeover
Password protected
Display in English or Metric units
Onboard Diagnostics
Product counter, label counter, elapsed hour meter,
dispense speed and product per minute display
Soft-touch keypad
Rate compensation synchronizes label to changing line
speeds

STEPPING MOTOR DRIVE

Increases speed and accuracy
Minimizes downtime/maintenance
Eliminates clutch/brake wear components

Q55 SPECIFICATIONS

Size: 21.49"(546mm) width x 30.31" (770mm) length
Approximate Net Shipping Weight: 50 lbs.
Actual Labeling Rate: Dependent upon label length and
product size (up to 180 products per minute)
Accuracy: Up to +/-1/32" (1mm)
Dispensing Speed: Variable, up to 1000"(24m) per minute
Label Drive: Digital stepping motor standard
Label Peel Plate: Pivots for maximum flexibility
Label Dimensions:
Maximum width = 6 7/8"(174mm)
Minimum width 1/2" (13mm)
Minimum length = 1/2" (13mm)
Roll Capacity: 12" (304mm) O.D. on 3" (76mm) I.D. core
Web Width: 7" (177mm)
Label Format: Die cut, waste removed (minimum 1/8" [3mm]
between labels)
Label Sensing: Photoelectric
Utilities: 220v AC, 50/60Hz, 10amps

OPTIONS

Recommended spare parts kit
Right or left-hand versions
Low label detection
End of web detection
Broken web detection
Adjustable Support Stand
Hot Stamp Imprinter
Missing imprint detection on label
Loose loop thermal transfer printers
Tamp unit

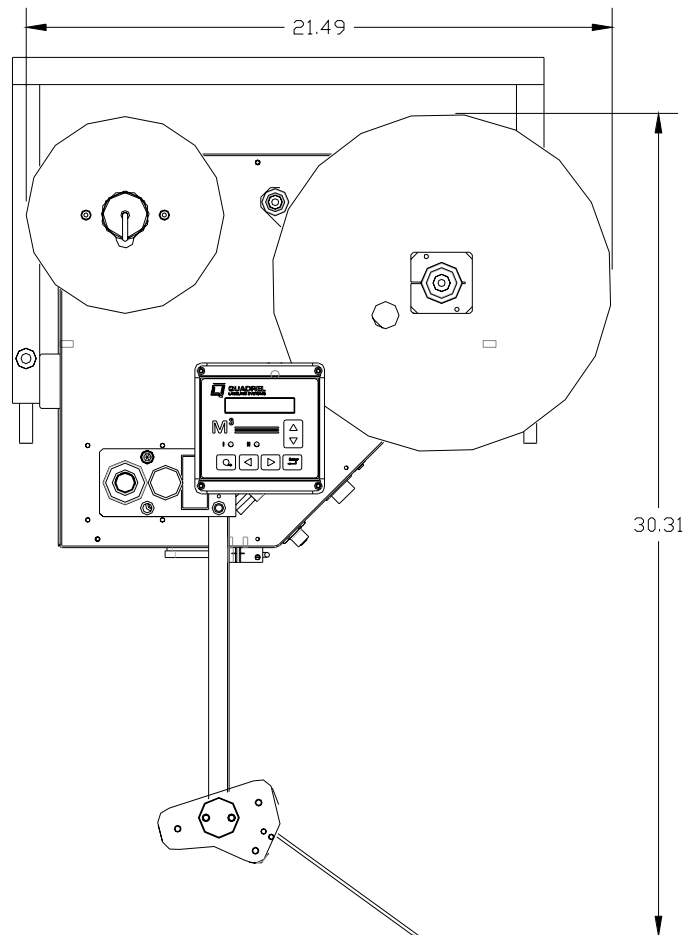

QUADREL
LABELING SYSTEMS

7670 Jenther Drive, Mentor, Ohio 44060
440-602-4700 Fax: 440-602-4701 E-Mail: labeling@quadrel.com

Packaging - Processing

Bid on Equipment

1-847-683-7720

www.bid-on-equipment.com