

MODULINE



Moduline

The Moduline is a compact, rugged, yet economically priced pressure sensitive labeling system for front/back, side panel or full wrap applications.

The system was designed to compete with low cost imported systems and is ideal for packaging lines with a production rate of 140 ppm or less.

The Moduline sets a new price threshold for an American made labeling system and is built with quality and durability from top to bottom.

The M3 microprocessor features "flash" memory. This replaces 'prom chip' technology and allows programming upgrades by email. The M3 also includes 'self teach' for instant set-up and changeover.

Additional features such as heavy gauge stainless steel construction and 'no change parts' product alignment make this system ideal for many pharmaceutical, cosmetic and personal care applications. Moduline is also popular with contract packagers looking for maximum flexibility at a competitive price.



QUADREL
LABELING SYSTEMS

7670 Jenther Drive, Mentor, Ohio 44060
440-602-4700 Fax: 440-602-4701 E-Mail: labeling@quadrel.com

Packaging - Processing

Bid on Equipment

1-847-683-7720

www.bid-on-equipment.com

CAPABILITIES PROFILE

SPECIFICATIONS

MODULINE

Speed: Up to 140 products per minute (dependent upon label/product dimensions)
Applied Accuracy: Up to +/- 1/32" (1mm) @ Sigma 2
Maximum Product Height: 14" (356mm)*
Minimum Product/Label Dimensions: Consult factory
Overall System Length: 120" (3.05m) standard*
Standard Width: (Single Head) 48" (1.2m)
(Dual Head) 86.7" (2.2m)
Utilities: 110/208VAC/Single Phase/60Hz
Approximate Net Shipping Weight: 1500 lbs. (682kg)
(dependent upon system configuration)

*CONSULT FACTORY FOR CUSTOM CAPABILITIES

PRODUCT HANDLING

- Fixed speed AC motors: conveyor speed 480" per minute (Optional variable speed package: up to 1000" per minute)
- 4-1/2" width x 120" length conveyor
- Chain aligners for product alignment
- Wrap station for round containers available in 12", 18" or 24" length

OPTIONS

Variable AC speed package: Up to 1000" per minute
Recommended spare parts kit
Right or left-hand versions
Low label detection
End of web detection
Broken web detection
Hot Stamp Imprinter
Clear label sensor
Missing imprint detection on label
Loose loop thermal transfer printers

Q55 LABELING HEAD

Accuracy: Up to +/-1/32" (1mm)
Dispensing Speed: Variable, up to 1000"(25m) per minute
Label Dimensions:
Maximum width = 6 7/8"(174mm)
Minimum width 1/2" (13mm)
Minimum length = 1/2" (13mm)
Roll Capacity: 12" (304mm) O.D. on 3" (76mm) I.D. core
Web Width: 7" (177mm)
Label Format: Die cut, waste removed (minimum 1/8" [3mm] between labels)
Label Sensing: Photoelectric
Utilities: 110v AC, 50/60Hz, 10amps@

M3.0 MICROPROCESSOR CONTROL

- Flash memory, computer programmable
- Self teach feature: instant setup and changeover
- 50 label presets
- Password protected
- Display in English or Metric units
- Onboard Diagnostics
- Product counter, label counter, elapsed hour meter, dispense speed and product per minute display
- Soft-touch keypad



Round Product Labeling System

Q55 Label Applicator

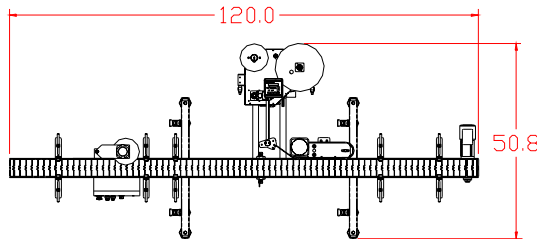
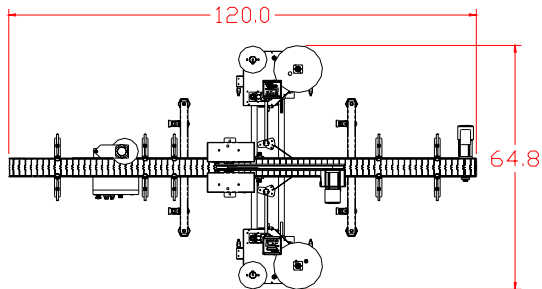
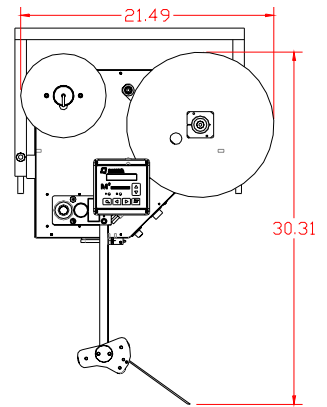

7670 Jenther Drive, Mentor, Ohio 44060
440-602-4700 Fax: 440-602-4701 E-Mail: labeling@quadrel.com

QLS, Incorporated reserves the right to modify specifications without notice 7/07

Packaging - Processing

Bid on Equipment

1-847-683-7720

www.bid-on-equipment.com