



800-523-3654

BALER & COMPACTOR

www.ptrco.com

Self-Contained Compactors



PT-300

(30 Cubic Yards)



The PT-300 Compactor has been engineered and manufactured to provide many years of reliable service. The heavy-duty structural steel components are welded by AWS certified technicians and water tested to ensure leak proof containment under high compaction forces. This unit has total U.L. approval, standard 3 button controls, On/Off key switch, mushroom stop, auto reverse and a *Sure-Tite*™ door seal.

Specifications

Charge Box Capacity	2 Cu Yd
Container Capacity	30 Cu Yd
Clear Top Opening (L x W)	41" x 60"

Electrical Equipment

Electrical Motor	208/230/460v	3 Phase
Horse Power		10
Electrical Control Voltage		120 VAC

Performance Characteristics

Cycle Time	31 sec
Total Normal Force	42,708 lbs
Total Maximum Force	51,250 lbs
Normal Ram Face Pressure	23.8 psi
Maximum Ram Face Pressure	28.5 psi

Hydraulic Equipment

Hydraulic Pump Capacity	10.5 gpm
Normal Pressure	2000 psi
Maximum Pressure	2400 psi
Hydraulic Cylinder (2) Bore	4"
Hydraulic Cylinder Rod	2.5"



PTR Baler & Compactor Company • 2207 E Ontario St. • Philadelphia, PA 19134
 215-533-5100 • (FAX) 215-533-8907 • 800-523-3654 • www.PTRCO.com



TITLE: PT-300 SELFCONTAINED REAR FEED EXAMPLE
 DWG. NO: AC401506

ELECTRICAL
 220V / 3 PHASE
 60 AMP. WALL DISCONNECT
 TIME DELAY FUSES

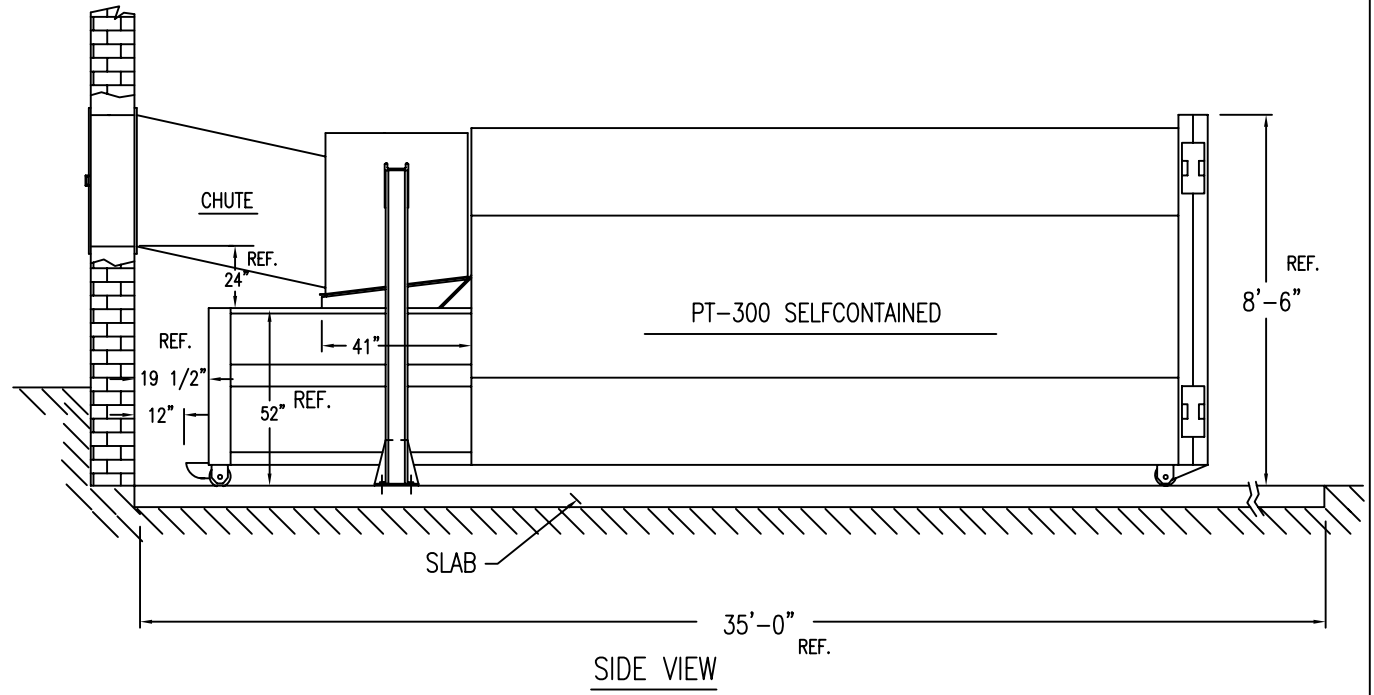
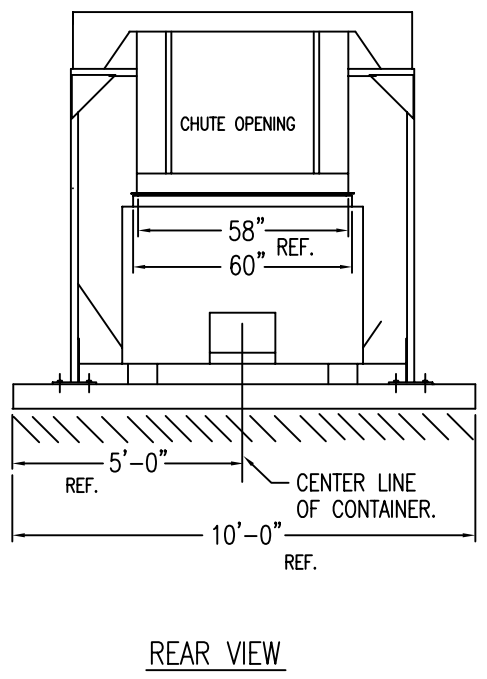
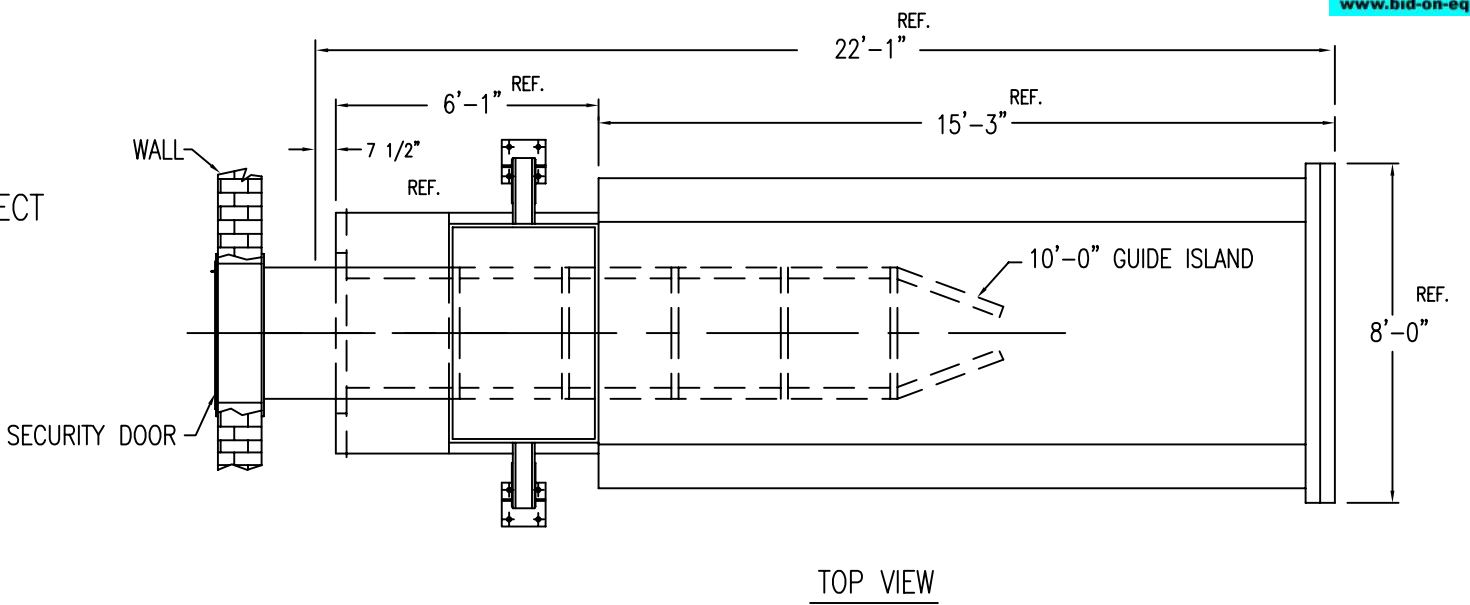

PAD MAT'L: MIN. 3000 CONCRETE WITH 12GA. SCREEN 6" SQ. MIN 6" THICK

PTR BALER & COMPACTOR

TITLE: PT-300 SELFCONTAINED SIDE FEED EXAMPLE

DWG. NO: AC401507

ELECTRICAL
 220V / 3 PHASE
 60 AMP. WALL DISCONNECT
 TIME DELAY FUSES

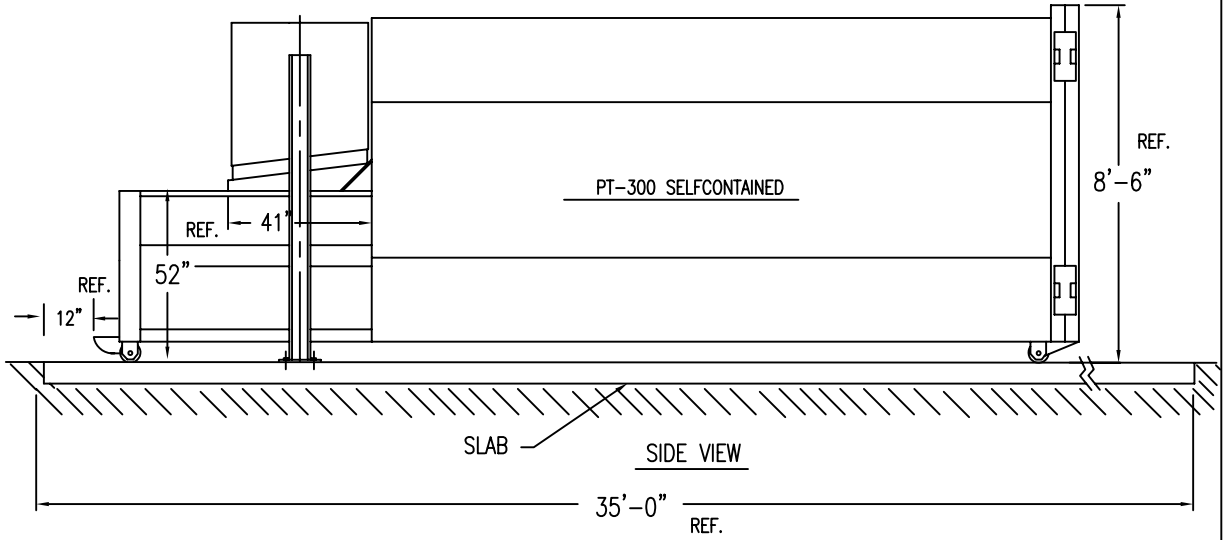
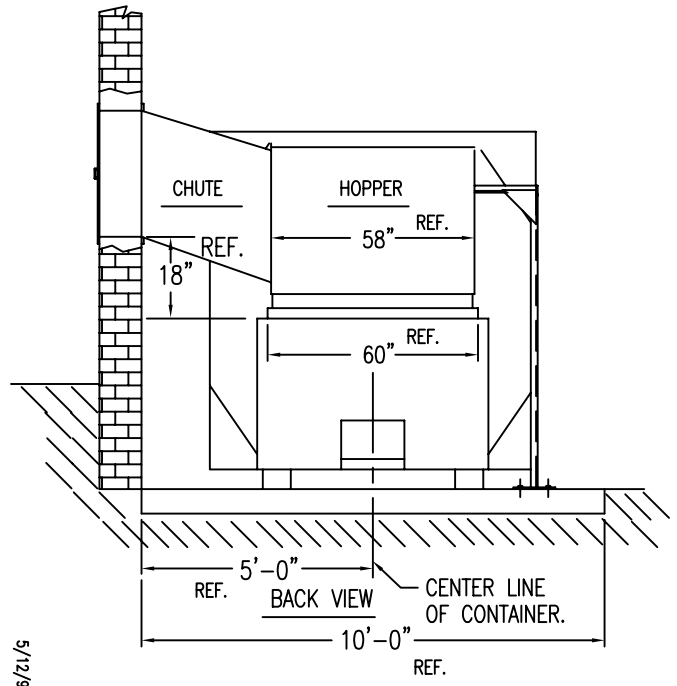
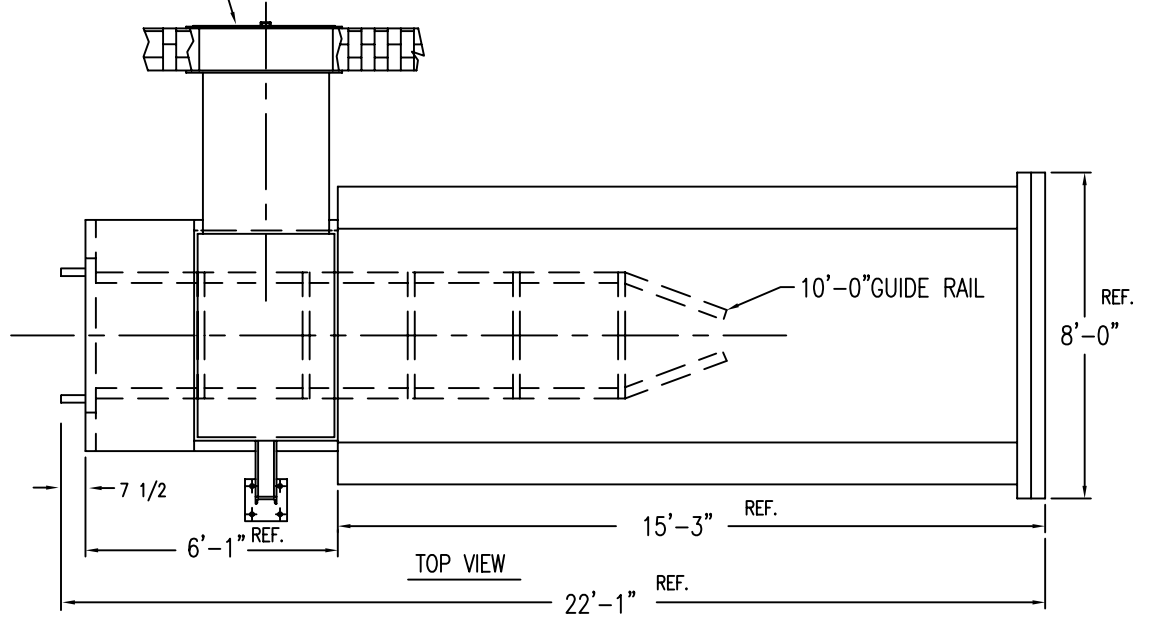
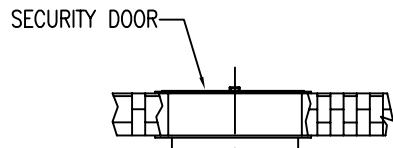

PAD MAT'L: MIN. 3000 CONCRETE WITH 12GA. SCREEN 6" SQ. MIN 6" THICK

PTR BALER & COMPACTOR

5/12/98

PTR BALER & COMPACTOR

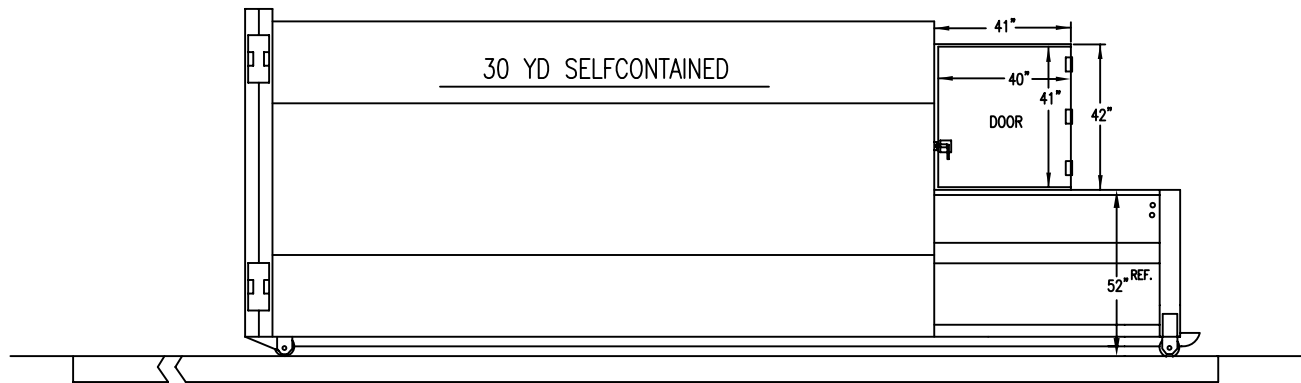
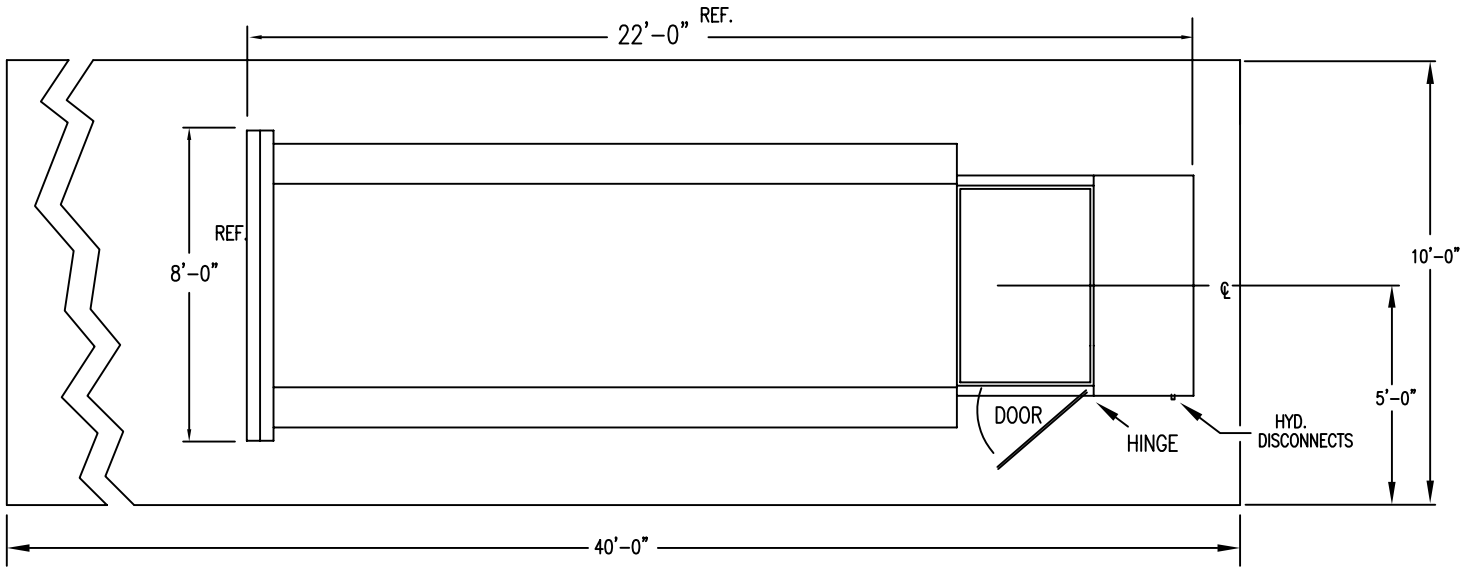

SIGN AND RETURN TO AUTHORIZE CONSTRUCTION

PAD = 3000 CONCRETE 6" THICK WITH MIN. 12 GAUGE SCREEN REINFORCEMENT

3/25/02