

PTR

800-523-3654

BALER & COMPACTOR

www.ptrco.com

Vertical Balers



324HD

Vertical Downstroke Baler

Designed For:

* Supermarkets * Retail Chains * Hospitals * Hotels * Malls *

This small but powerful machine has been specifically engineered for applications with limited space or budget. The 324HD Series has all of the important safety features that make us the leader in the vertical baler industry.

Dimensional Data

Overall (Width x Depth x Height)	39" x 34" x 95.5"
Feed Height	32"
Baler Chamber (Depth x Height)	24" x 28"
Load Opening (Width x Height)	30" x 19"

Bale Size

Bale Width	30"
Bale Depth	24"
Bale Height	30"
Bale Weight	50 to 200 lbs

Performance Characteristics

Cylinder Bore	4" x 2.5"
Rod Stroke	32"
Motor	3 hp
Cycle Time	54.2 sec
Systems Pressure	1600 – 2100 psi
Platen Force	20,100 lbs
Control Voltage	110 – 120 VAC
Electrical Motor	3 Phase
	208 / 230 / 460



PTR Baler & Compactor Company • 2207 E Ontario St. • Philadelphia, PA 19134
215-533-5100 • (FAX) 215-533-8906 • 800-523-3654 • www.PTRCO.com



Printed in the U.S.A.
© PTR Baler & Compactor

PTR BALER & COMPACTOR

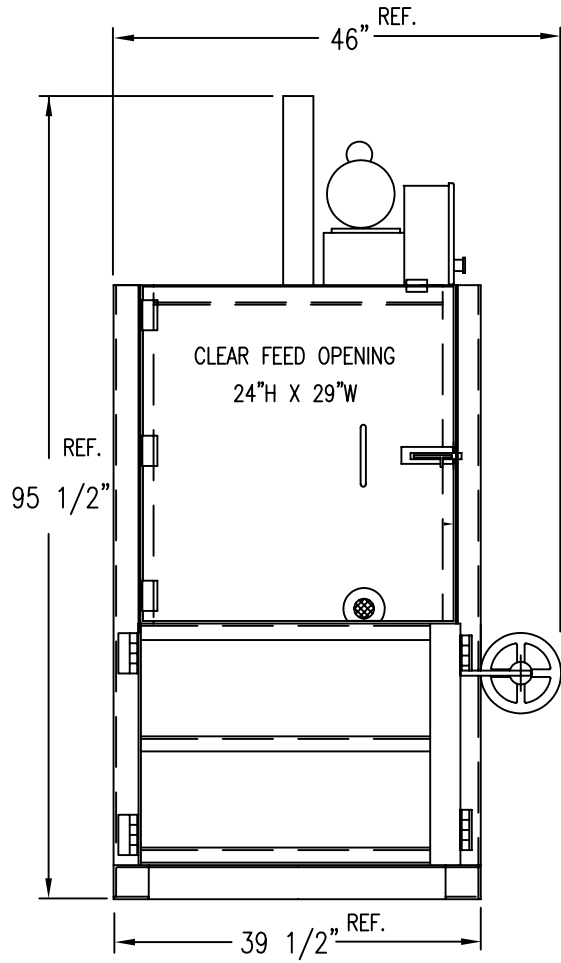

FRONT VIEW

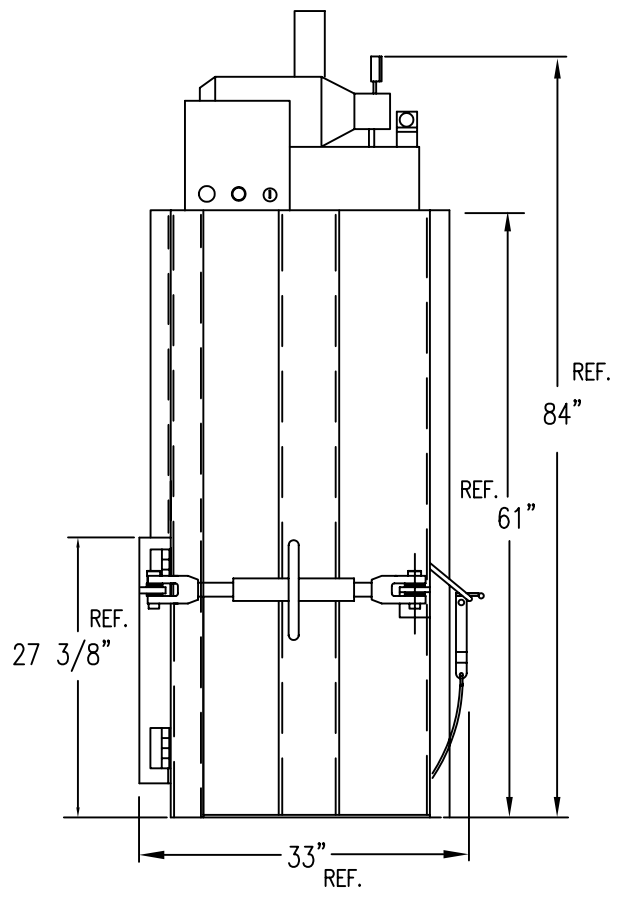

SIDE VIEW