



800-523-3654

BALER & COMPACTOR

www.ptrco.com

Vertical Balers

Totally

Listed!



2300HD

Vertical Downstroke Baler

Designed For:

* Warehouses * Retail Chains * Distribution Centers * Manufacturing Plants *

Our most popular high density downstroke 60" baler the 2300HD is constructed with heavy duty structural steel and produces bales up to 1,100 lbs.

Dimensional Data

| | |
|----------------------------------|------------------|
| Overall (Width x Depth x Height) | 78" x 41" x 152" |
| Feed Height | 54.5" |
| Baler Chamber (Depth x Height) | 30" x 48" |
| Load Opening (Width x Height) | 60" x 27" |

Bale Size

| | |
|-------------|------------------|
| Bale Width | 60" |
| Bale Depth | 30" |
| Bale Height | 48" |
| Bale Weight | 850 to 1,100 lbs |

Performance Characteristics

| | |
|------------------|-----------------|
| Cylinder Bore | 6" x 3 1/2" |
| Rod Stroke | 48" |
| Motor | 10 hp |
| Cycle Time | 56 sec |
| Systems Pressure | 2000 – 2700 psi |
| Platen Force | 56,500 lbs |
| Control Voltage | 110 – 120 VAC |
| Electrical Motor | 3 Phase |
| | 208 / 230 / 460 |



PTR Baler & Compactor Company • 2207 E Ontario St. • Philadelphia, PA 19134
215-533-5100 • (FAX) 215-533-8906 • 800-523-3654 • www.PTRCO.com



Printed in the U.S.A.
© PTR Baler & Compactor

2300HD

60" HIGH DENSITY VERTICAL BALER SPECIFICATIONS

A. Manufactured

1. To meet American National Standard Institute Specifications Z245.5 - 1997
2. Total UL Approval on entire baler including all electrical, mechanical & hydraulic components

B. Capacity

1. 850-1100 lb. corrugated bale weights

C. Frame

1. Bale Chamber of 60" x 48" x 30"
2. Frame width of 75" maximum
3. Frame depth of 40" maximum
4. Frame height of 103" maximum
5. Height of 152" maximum
6. System Pressures - Operating - 2,000 PSI
Maximum - 2,700 PSI
7. Ram Force Pressure - Normal - 56,500 lbs.
Maximum - 76,341 lbs.

D. Ram

1. A 3/8" thick ram platen of trapezoid shape
2. Ram sides of one piece formed plate for proper force distribution while under extreme pressure
3. Platen, steel and nylon wear pads guided on sides to maximize direction of hydraulic forces
4. Weld construction utilizing the Outershield welding procedure; providing 92,000 PSI weld tensile strength

E. Cylinder

1. Single stage, double acting 6" bore, 48" stroke, 3 1/2" rod cylinder with a 2" thick mounting flange on the rod end
2. The cylinder is connected to the platen in a manner that eliminates the compression force from acting on the connecting pin during the compression cycle
3. High density machined steel cylinder cup

F. Power Unit

1. Will be tri-voltage, three-phase
2. Will be 10 HP Motor unit producing maximum ram forces of over 70,000 lbs. With 10.5 GPM pump.

G. **Charging Gate**

1. Gate is counter balanced with weights through a link chain and sprocket system
2. Gate is manual, safety, pull down type with automatic lifting capability, moving on replaceable nylon wear guides

H. **Bale Chamber Door**

1. Door structure and hinges capable of withstanding the forces generated by the power unit, during the baling cycle
2. Door lock system will engage and disengage by a 10" cast steel hand wheel assembly, capable of safely holding the door in a locked position and allowing a slow diminishing of forces against the door when opening. Front and rear retainer dogs are placed on the door and back of the baler.

I. **Semi-Automatic Bale Ejector System**

1. Consist of heavy-duty 1/4" link chains, attached to T Hooks on one end and to the baler frame on the other end
2. T Hooks are designed to automatically disengage on the first down cycle of the ram in the automatic mode

J. **Control Panel**

1. Will provide a manual and automatic mode of operation
2. Will have a key operated power On/Off Switch, and manual Up-Down/Start combination switch, and an emergency stop button with a full bale light.

K. **Automatic Safety Electrical Systems**

1. A concealed electric magnetic field proximity switch to insure charging gate is closed and remains closed during travel of ram
2. An activator ram switch to insure that the platen will stop if the gate is opened at any point in the baling cycle
3. Chamber door switch to insure door is completely closed and locked while the baler is operating in the automatic mode
4. Safety switch to insure a complete shut down when ram completes the full automatic cycle

L. **Finish**

1. High quality industrial enamel paint

M. **Warranty**

1. One Year Parts & Labor with an additional 2 Years (3 Years Total) on the major components (Motor, Pump, Cylinder, Directional Valve and Structure).

N. **Service and Parts**

1. Factory authorized Parts and Service Organization with 24-Hour Customer Service Hotline

O. **Special Safety Benefits**

1. Safety/Operational Videotape provided with each baler
2. \$10,000,000 Product Liability Insurance Coverage

PTR BALER & COMPACTOR

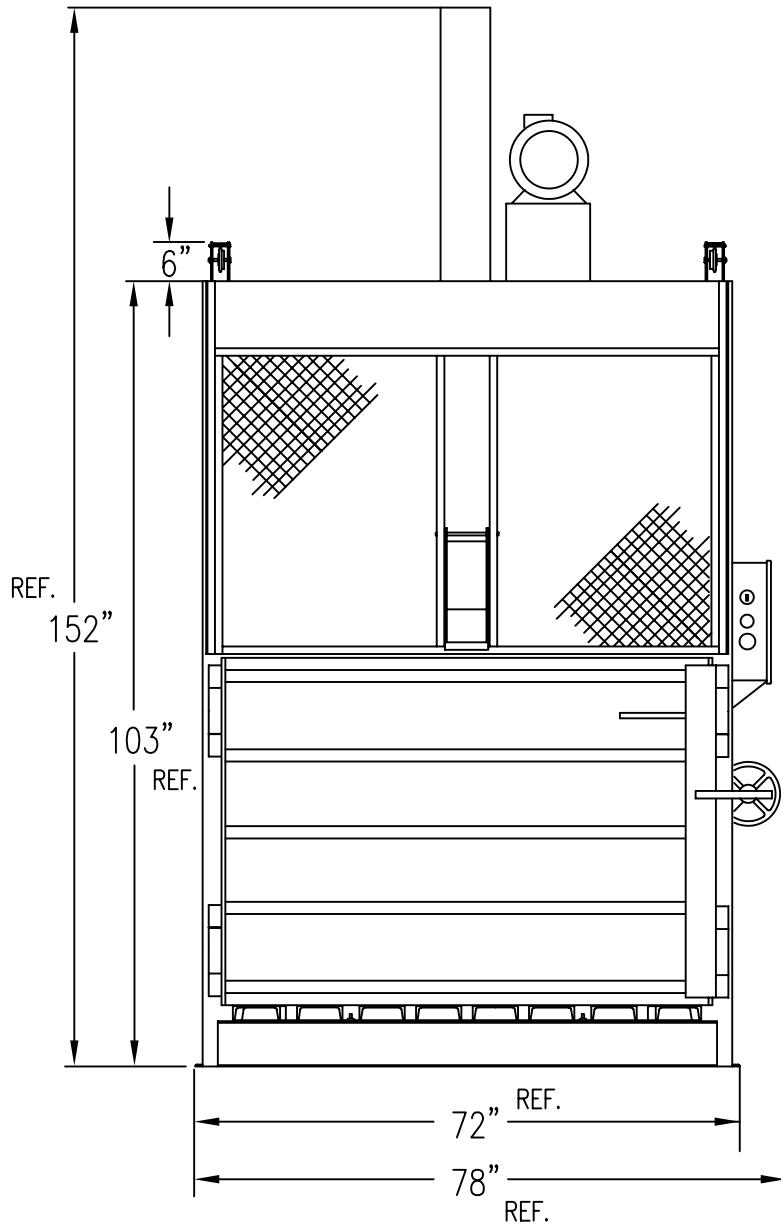

FRONT VIEW

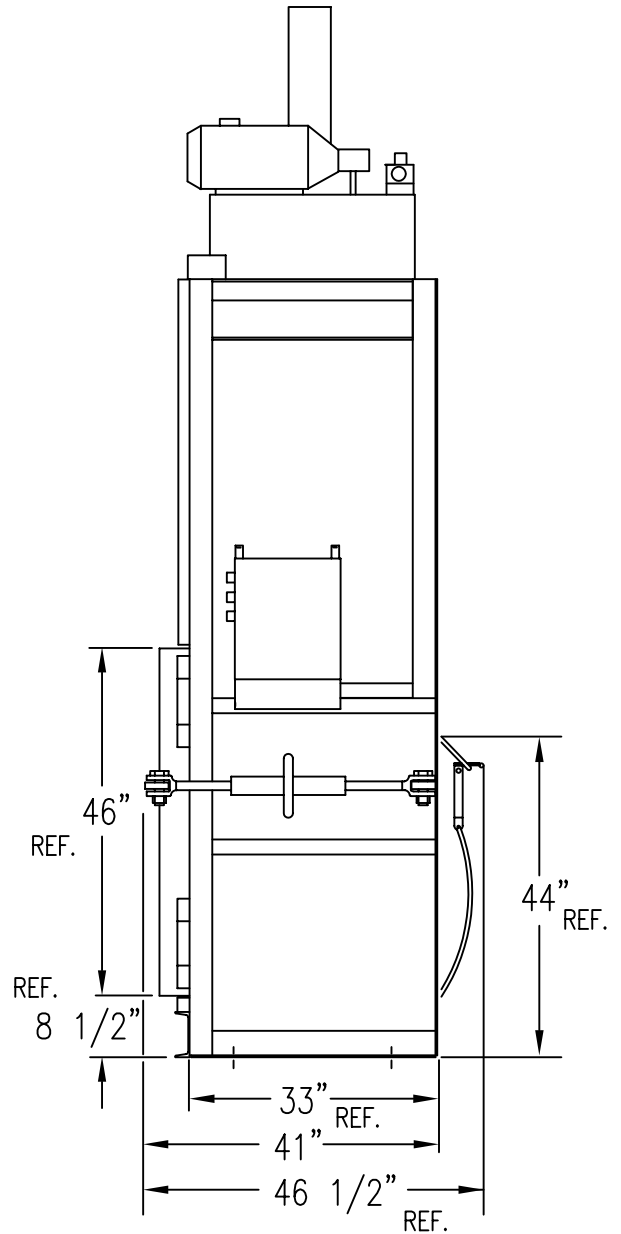

RIGHT SIDE

BALE: 60" W X 30" D X 48" H 850 TO 1100 LBS.
 60" X 30" 1800 SQ. IN 12.5 SQ. FT.
 60" X 48" 2880 SQ. IN 20 SQ. FT.
 30" X 48" 1440 SQ. IN 10 SQ. FT.

FLOOR SPACE REQUIRED AT FLOOR: 72" X 33" 2376 SQ. IN. 16.5 SQ. FT.

FLOOR SPACE REQUIRED: 78" X 46 1/2" 3627 SQ. IN. 25.2 SQ. FT.

FLOOR SPACE REQUIRED WITH WALL CLEARANCES (DOOR CLOSED): 96" X 59" 5664 SQ. IN. 39.3 SQ. FT.

PTR BALER & COMPACTOR

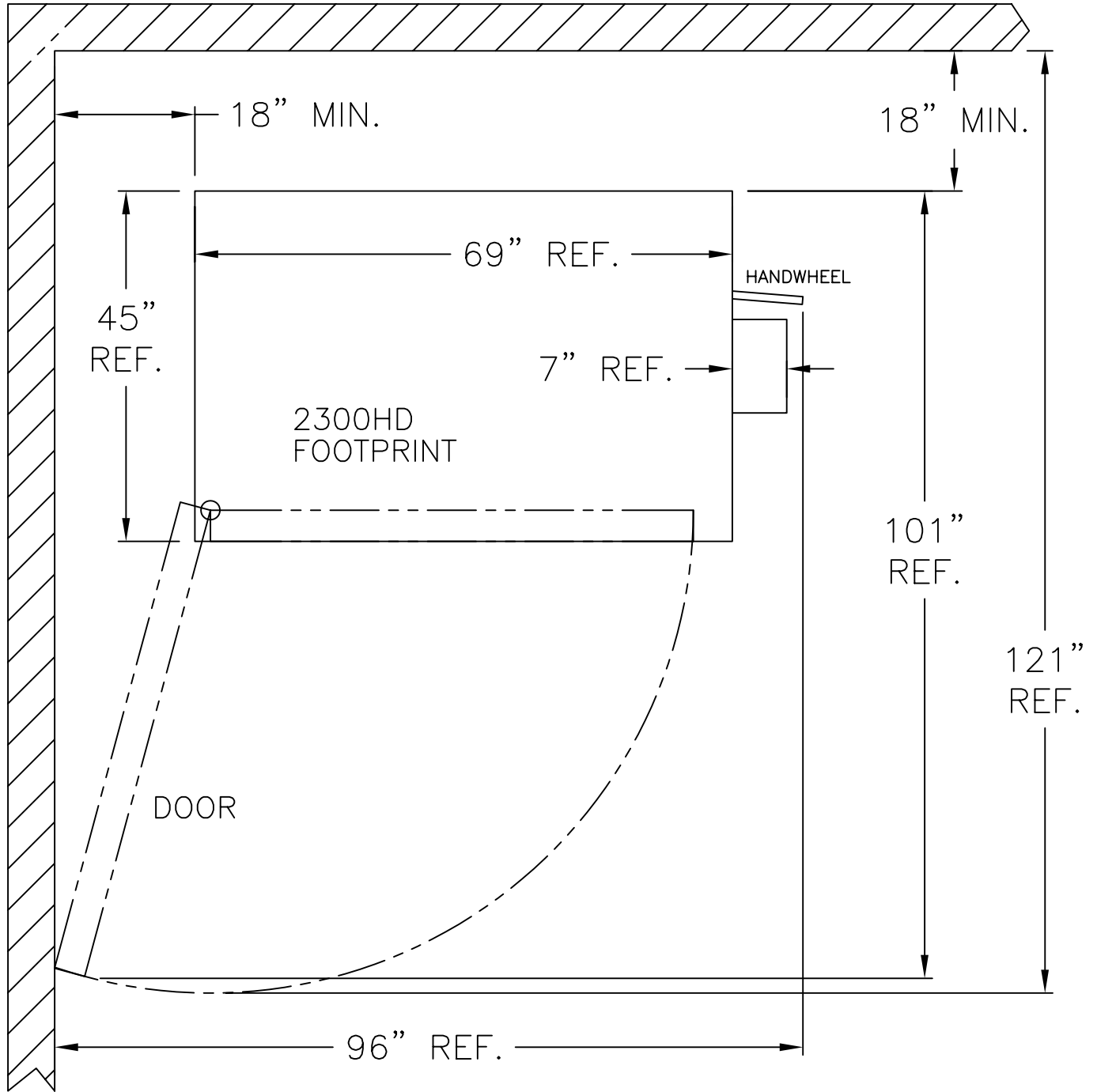

TITLE: 2300HD CEILING HEIGHT REQ. FOR TIPPING UPRIGHT AT INSTALL DWG. NO: AB401984

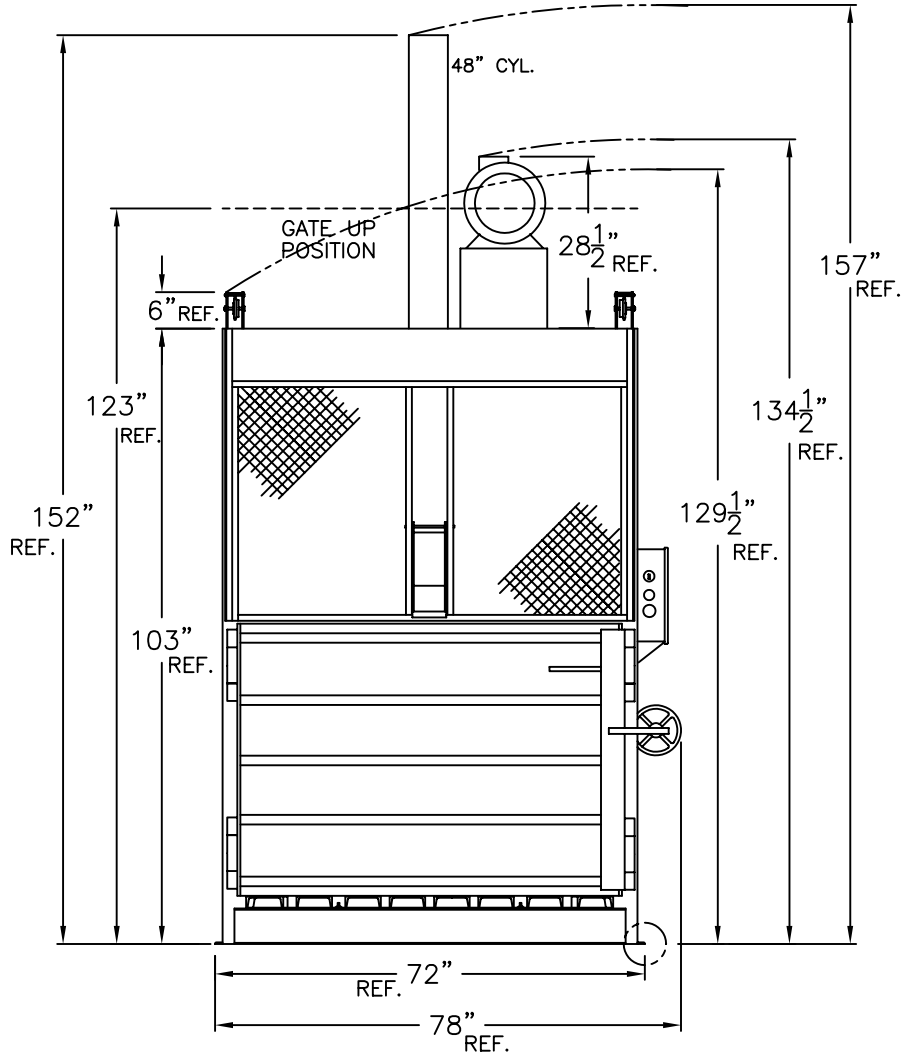

2300HD

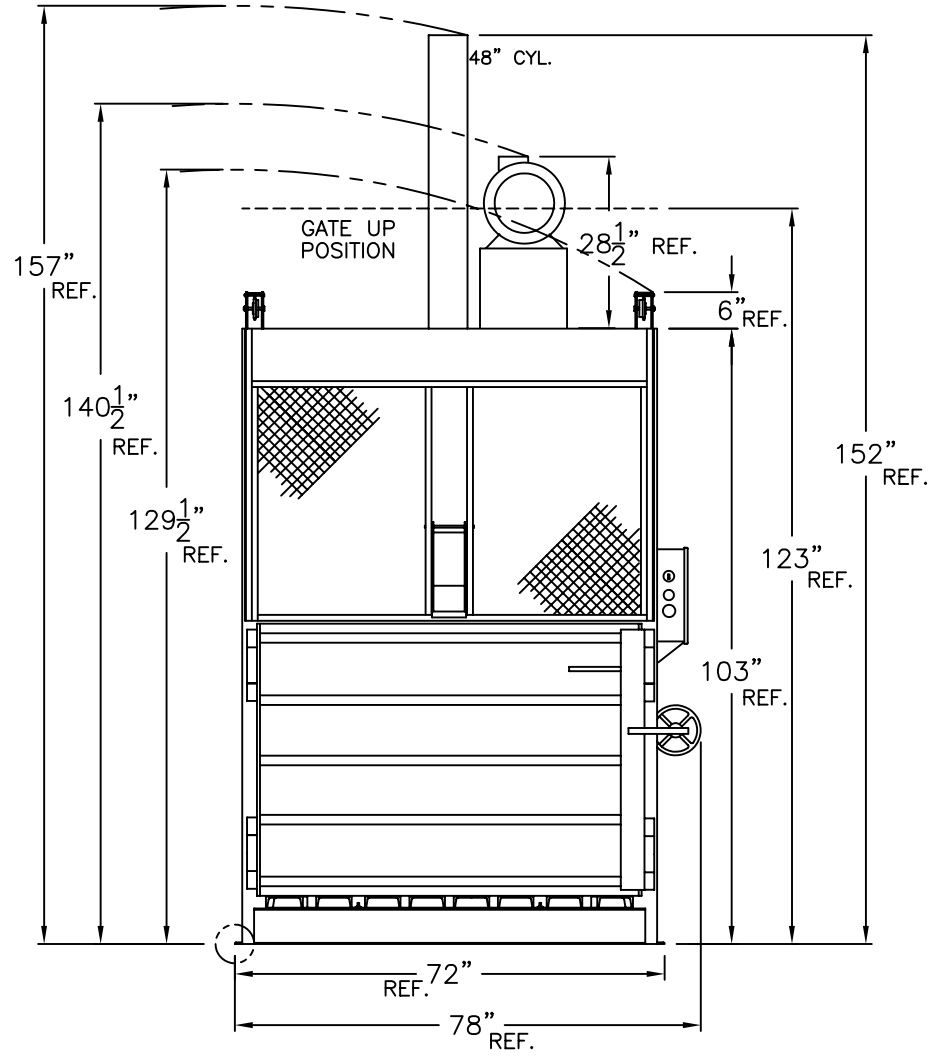

2300HD