

PHOENIX

ENGINEERING AND DESIGN, INC.

BUILDERS OF WORLD CLASS PACKAGING EQUIPMENT

Rotary Turntable Indexing Machines

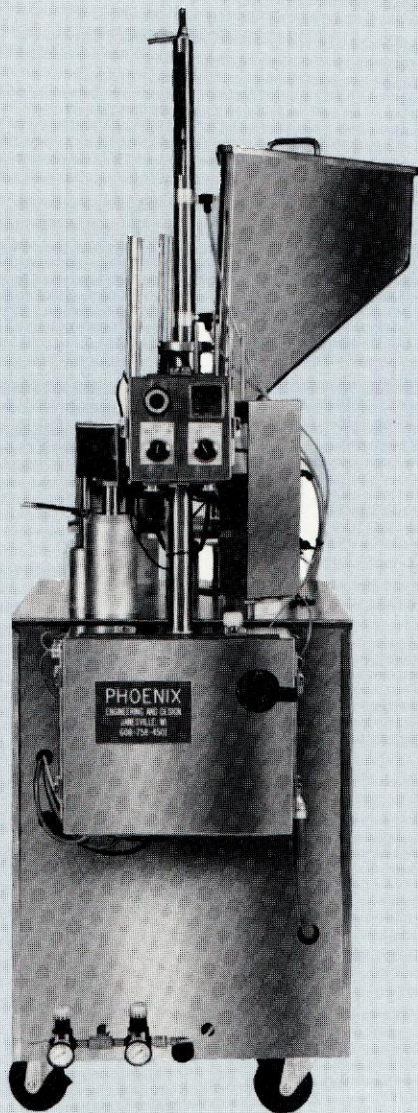

MODEL FT-6

This standard Phoenix machine is a well designed unit. It is operator friendly and simple to maintain. This is the latest technology.

It will automatically dispense containers, fill product, "Tamper-evident" seal the container openings with a pre-cut film, foil, or any other lidding that would be compatible to the container material. This FT-6 has exceptional product filling accuracy and can fill a wide variety of products, ranging from liquids, pre-stirred yogurts, sour cream, puddings, and solids.

- Container Dispenser - containers 7/8" up to 4 1/2" max. diameter, the height of container can be 4 3/8" max.
- Fill Speeds - Dependent on product viscosity and head space up to 48 containers per minute (C.P.M.)
- Bottom-Up-Fill - At the fill station the position of the container will be automatically raised to fill container. This is used only on products which require Bottom-up-Fill. (Please note this is an option.)
- Container present - fill, No container - no fill. (Please note this is an option.)
- Container present - die cut foil seal placed, No container - no foil seal. (Please note this is an option.)
- No Drip Filler and Accuracy - Dependent on product constant viscosity, the accuracy reports $\pm 1/2\%$.
- "Tamper-Evident" Heat Seal -Hermetically heat-sealed pre-cut die film, foil or stock laminations placed on containers.
- Coder - Optional mechanical date coder.
- Container Removal - Automatic by machine.
- Cleaning - The machine can be washed down "Tamper-Evident", heat seal head is totally water proof.
- 3A, USDA and F.D.A. standards approved or pending.
- Phoenix supplies packaging machines world wide with service.

Please read reverse side.

We at Phoenix believe the model FT-6 is the best unit machine of its kind in the world today. At initial purchase the machine is supplied with one (1) of three (3) changeable product fillers for the customers' need. For example, the filler chosen can be slurry type such as pre-stirred yogurt, salsa, sour cream, etc. The second type filler would be liquid type such as water, juice, etc. The third type would be dry type such as granola, peanuts, dry ground coffee, etc.

Standard Fills

- Apple Sauce
- Bird Seed
- Bread Crumbs
- Catsup
- Caviar
- Cheeses
- Chocolate Chips
- Cole Slaw
- Cooking Oils
- Cottage Cheese
- Diced Peaches & Strawberries
- Dry Dog & Cat Food
- Dry Ground Coffee
- Dry Fruits
- Dry Ground Tea Leaves
- Dips, Various
- Fish Bait
- Fish Ground
- Fruits
- Gelatins
- Glues
- Granola
- Italian Ice
- Jams
- Jello
- Juices
- Margarine
- Medical Products
- Motor Oil
- Mustard
- Paint Samples
- Peanuts
- Pickle Relish
- Peanut Butter
- Popcorn Kernels
- Potato & Macaroni Salads
- Powders
- Pre-stirred Yogurt
- Puddings
- Raisins
- Seeds
- Salsa
- Shampoo
- Soup
- Sour Cream
- Spackling Compound
- Water
- Yogurt
- Other products to numerous to mention.

Specifications:

- Container Volume Size: 1/2 to 48 ounces/1,360 grams
- Machine Fill Speed: Up to 48 containers per minute depending on product viscosity
- Closure: Pre-cut peel-off lid membrane
- Floor Space: 30.5 x 30 x 52.5 highest point
- Bench Model
- Air Supply: Liquid: Filling, self-contained air supply
Solids: 70 P.S.I. clean dry air (customer supplied)
- Electrical Service: Standard 110 v - 60 hz (customer supplied)
- Note: Customer must specify if other than standard electrical

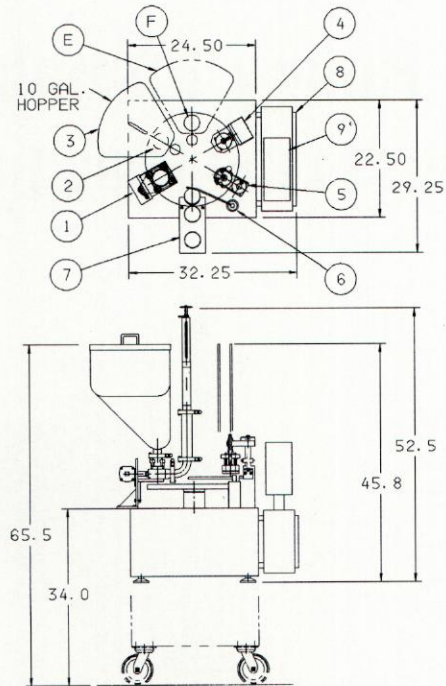

Standard Machine Features

1. Container Dispenser
2. Product Filler
3. Product Hopper
4. Seal, Pick and Place (Pre-cut Die Film)
5. "Tamper Evident" Seal
6. Container Discharge
7. Off End Dead Plate
8. Control Box NEMA 4x Hose Down
9. Operator Control Box NEMA 4x Hose Down

Machine Options

- A. Container Bottom Up Fill
- B. Container Size Change Parts
- C. Container Present - Fill No Container - No Fill
- D. Container Present - Place Pre-Cut Die Film, No Container - No Film Seal.
- E. Second Product Hopper
- F. Product Filler
- G. Offload Conveyor
- H. Roll Around Floor Model
- I. Mechanical Date Coder

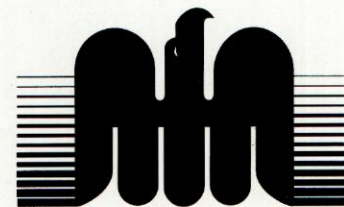

Phoenix Engineering & Design
Division of LP Productions Inc.

"Builders of World Class Packaging Equipment"

4634 Case Drive, P.O. Box 1467 • Janesville, WI 53546
Phone: (608) 758-4501 • Fax: (608) 752-9282