

# Model VP15-T VersaPack® Hand Packing System



## New Hand Packing System for a variety of products up to 15 CPM.

Pearson's VP15-T VersaPack® Hand Packing System is an all in one, semi-automatic system designed to erect and bottom seal cases with tape, advance the case to a hand packing station and then continue the full cases to a top taping case sealer at speeds up to 15 cases per minute. The VP15-T utilizes Pearson's proven concepts with new technology to offer the highest reliability in its class.

The VP15-T erects and top seals a wide range of RSC & CSSC corrugated cases. The integrated manual load station includes a configurable product infeed conveyor designed to convey both flexible and ridged product with an automatic stop/start feature that runs on demand. The hand packing station features an adjustable height product infeed conveyor and an adjustable width case conveyor allowing the operator to work close to the case without reaching over a conveyor. Operator controls and case loading are located in close proximity of the operator for ergonomics.

Cases are erected on demand and discharged onto the load station conveyor. The case to be

loaded is clamped in position where it can easily be loaded with a minimum of one case in queue ready to index to the load position. After the case is loaded the operator flags the ergonomic finger sensor releasing the loaded case to the sealer and allowing the case in queue to transfer to the load position.

The VP15-T offers the following features:

- **Allen-Bradley® PLC**
- **AB® Pressure Sensitive Tape Head**
- **Inventory control photo eye at discharge**
- **Electrically interlocked safety guard package**
- **Quick 5 minute changeover**
- **UL® Listed Control Panel**
- **Stainless steel construction optional**

Like all Pearson products, the VP15-T is backed by Pearson's experienced factory professionals as well as one of the largest teams of PMMI certified regional service technicians in the industry, available 24-hours a day, 7-days a week - worldwide.

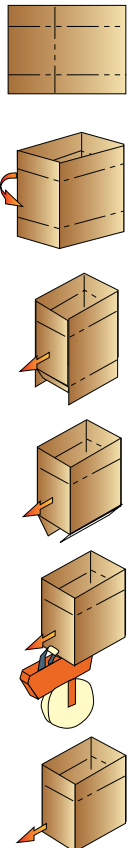

Packaging - Processing

**Bid on Equipment**

1-847-683-7720

[www.bid-on-equipment.com](http://www.bid-on-equipment.com)

CASE PACKERS ○ CASE ERECTORS ○ BAG INSERTERS & UNCUFFERS ○ CASE SEALERS

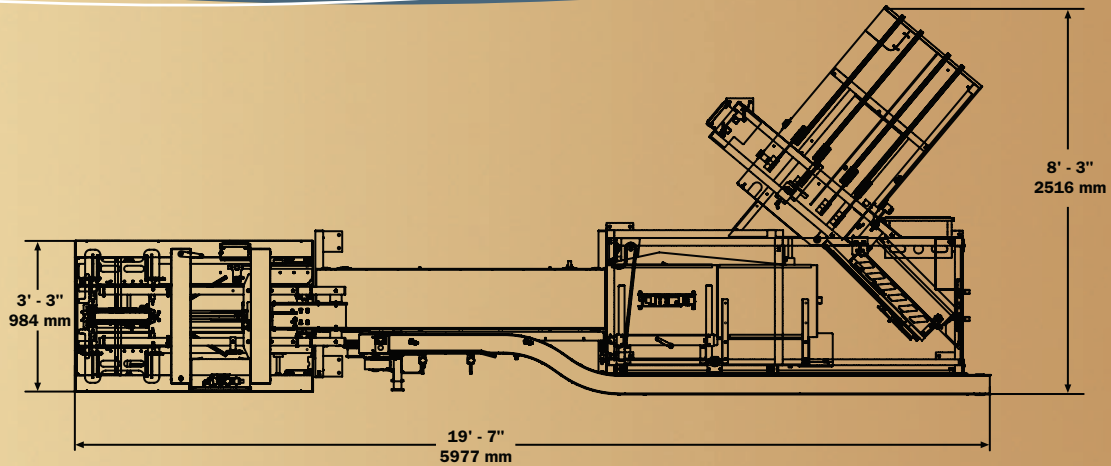

PLAN VIEW

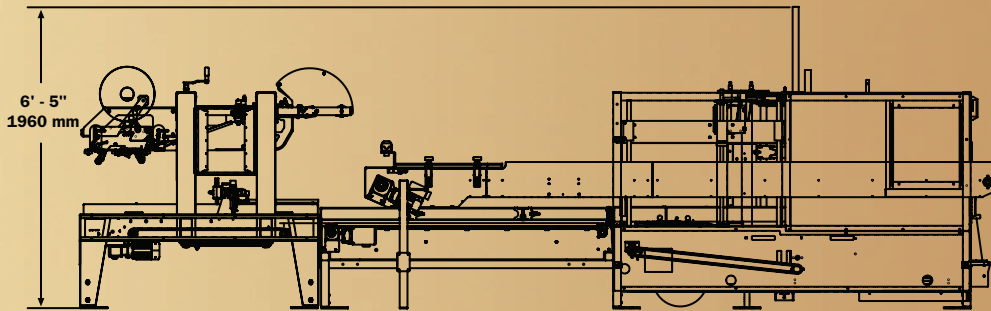

ELEVATION VIEW

### UTILITY REQUIREMENTS VP15-T

**Electrical:**

Qty of two 110V single phase or 220V single phase outlets required, 1 at 17.3 Amps and 1 at 7.7 Amps 3.52 total kVA

**Pneumatic:**

0.383 SCF/cycle @ 80 PSI (0.0120 m³ /cycle @ 551.2 KPa)

**Shipping Weight:**

2900 lbs. (1317 kg)

### ERECTED CASE SIZE RANGES

LENGTH	WIDTH	CLOSED DEPTH	OPEN DEPTH*
7.5" – 24**"	7.5" – 16"	3" – 18.5"	5" – 23"
191 – 610 mm	191 – 406 mm	76 – 470 mm	127 – 584 mm

### KNOCKED-DOWN SIZES

LENGTH	WIDTH	BOTTOM FLAP WIDTH
10" – 40"	7" – 30"	3.5" - 8"
254 – 1016 mm	178 – 762 mm	89 – 203 mm

\* Top flaps open, bottom flaps closed. Please consult the factory with your project specifications.

\*\* For case lengths above 18" (457 mm) consult Pearson for maximum available speeds.

### MACHINE SPECIFICATIONS

	LENGTH*	WIDTH	HEIGHT	SPEED
<b>VP15-T</b>	19' - 7"	8' - 3"	6' - 5"	15 cpm
<b>Pressure Sensitive Tape</b>	5977 mm	2516 mm	1960 mm	

\* Overall system length varies depending on product being packed and length of product and case conveyors per customer specifications.



RSC

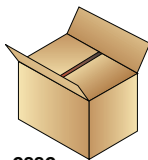

CSSC

