

Model GTL-3N1 Case Packer (Goodman Three-In-One™)



Erect, Pack and Seal Cases Within One Compact Machine!

Pearson's GTL-3N1 Case Packer (Goodman Three-In-One™) is a complete case packing system custom built to your project specifications. The GTL-3N1 reliably erects RSC cases, packs products either horizontally or vertically and seals full cases with either tape or hot melt adhesive at speeds up to 120 packages per minute depending on configuration.

The GTL-3N1 can pack a variety of package sizes and pack patterns for flexible, rigid and semi-rigid products. With a no-tool changeover of less than 10 minutes, you can run vertical or horizontal pack patterns on the same machine. The GTL-3N1 comes standard with a vacuum blower system reducing your overall air consumption. Optional stainless steel

construction with washdown for caustic production environments is also available. Built on a single, compact unified frame, the GTL-3N1 is your complete case packing system in one machine.

The GTL-3N1 can be equipped with one or two product conveyors to accept up to two sources of product into the machine. The layer forming conveyors of the GTL-3N1 are customized to handle your specific product type.

Like all Pearson products, the GTL-3N1 is backed by Pearson's experienced factory professionals as well as one of the largest teams of PMMI certified regional service technicians in the industry, available 24-hours a day, 7-days a week - worldwide.

**Packaging - Processing
Bid on Equipment**

1-847-683-7720

www.bid-on-equipment.com

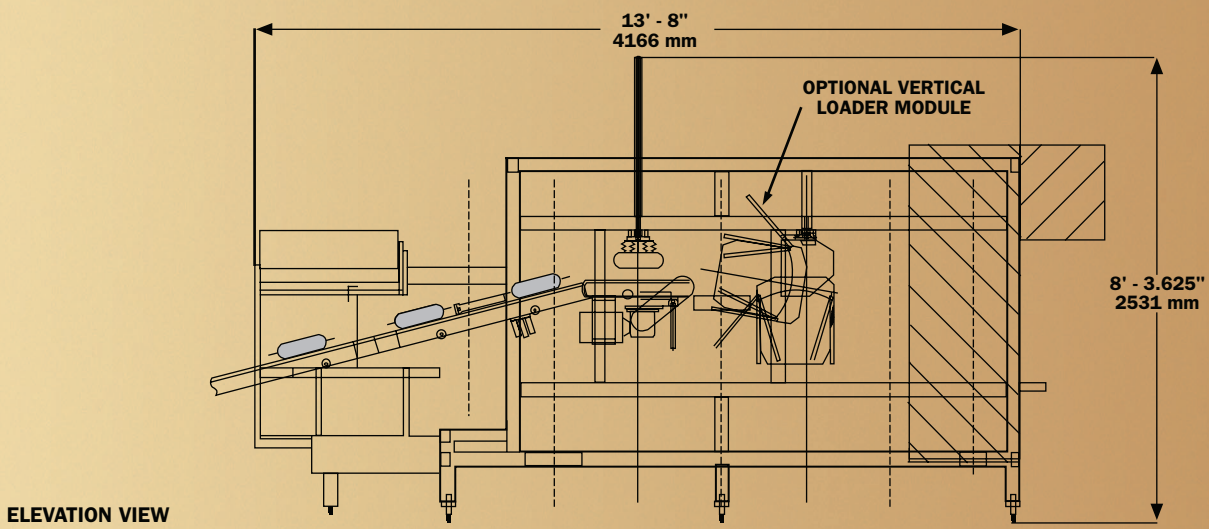
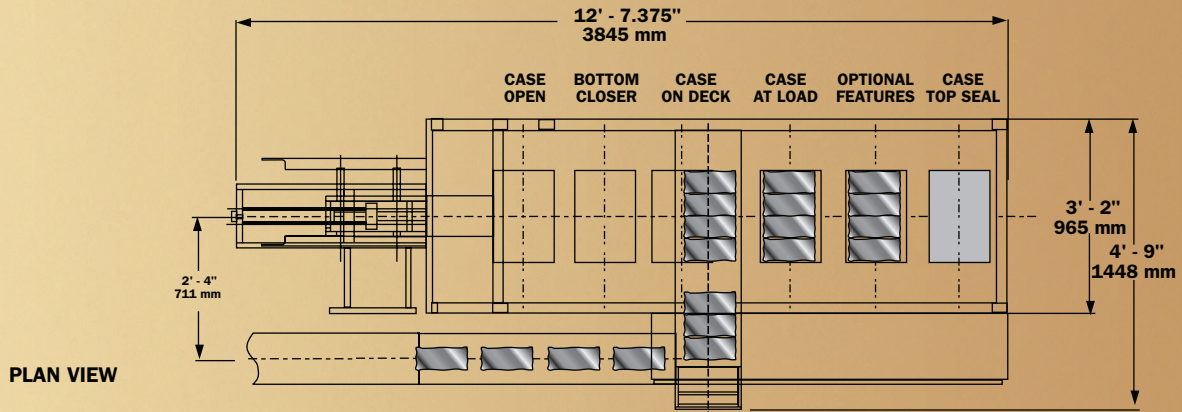

UTILITY REQUIREMENTS GTL-3N1 CASE PACKER

Electrical:
480V, 3-phase, 60 Hz Std.

Pneumatic:
Dependent on final configuration

Shipping Weight:
Dependent on final configuration

ERECTED CASE SIZE RANGES		
LENGTH	WIDTH	DEPTH
8" – 25"	6" – 13"	4" – 14"
203 – 635 mm	152 – 330 mm	102 – 356 mm

Please consult factory with project specifications for final case ranges.

Pearson's Winning Formula!

- Complete case forming, packing and sealing system
- Horizontal or vertical packing configurations
- Flexible pack patterns
- Speeds up to 120 products per minute
- Compact footprint for space savings

EXAMPLE PACK PATTERNS

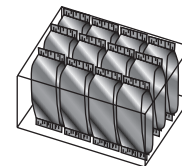

VERTICAL PATTERN

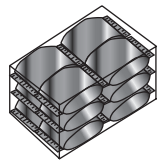

"B" PATTERN

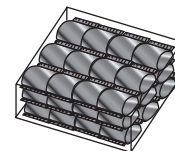

MULTIPLE ROW
"A" PATTERN

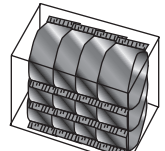

"A" HEAVY SHINGLE