

Model CS30-RT Random Case Sealer

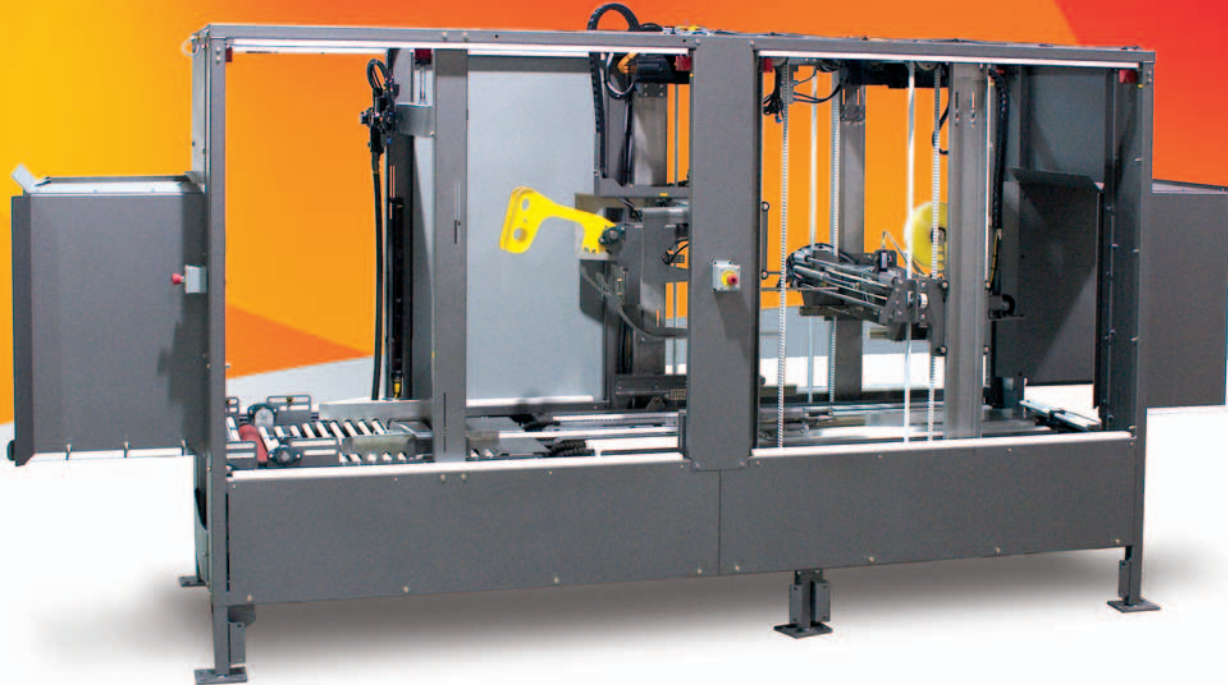

Fully random continuous case sealing at speeds of 30 cases per minute!

Pearson's Model CS30-RT Random Case Sealer is a high-speed automatic machine capable of randomly top and bottom tape sealing different size cases within a given range. The compact and rugged continuous motion sealer runs at 30 cases per minute across the entire case size range. Built for speed and flexibility, the CS30-RT is designed for the most demanding production environments. The CS30-24RT is the intermediate version of the CS30-RT & seals larger cases at 24 cases per minute

The CS30-RT comes standard with Fully Random configuration. The Fully Random design allows the machine to run an unlimited number of random case sizes, measuring each case as it enters the flap folding area and adjusting accordingly.

Available in both mild steel or stainless steel construction, the CS30-RT provides high speed capability, improving plant productivity and allows for

future capacity increases. Powered case centering, powered flights and top case squaring ensures properly formed cases every time. An available selective sealing option allows for selection of a top only sealing mode, bottom only sealing mode or pass through mode.

Each CS30-RT features an Allen-Bradley® PanelView touchscreen, PackML compliance standard, UL® Listed Control Panel, 24 Volt DC control package, Tape Fault sensing package, Allen-Bradley® PLC, a full perimeter guard package, and large case size range.

Like all Pearson products, the CS30-RT is backed by Pearson's experienced factory professionals as well as one of the largest teams of PMMI certified regional service technicians in the industry, available 24-hours a day, 7-days a week - worldwide.

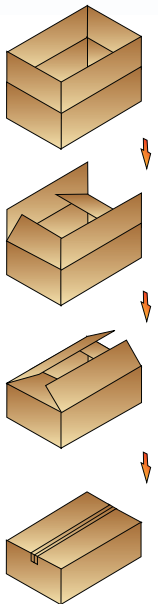

**Packaging - Processing
Bid on Equipment**

1-847-683-7720

www.bid-on-equipment.com

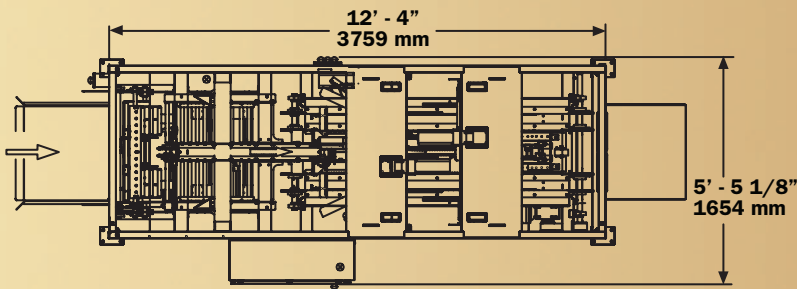

PLAN

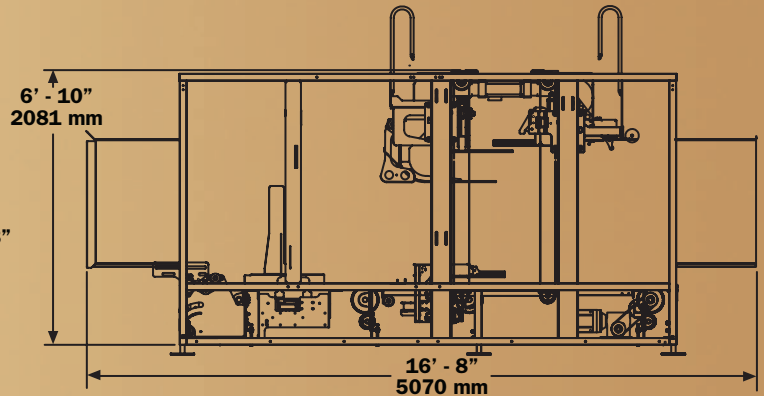

ELEVATION

UTILITY REQUIREMENTS CS30-RT

Electrical:

230/460V, 3-phase,
60 Hz Std., 4.68 kVA

Pneumatic:

0.82 SCF/Cycle @ 80 PSI
(0.023 m³/cycle @ 551.2 KPa)

Shipping Weight:

5200 lbs (2363kg)

ERECTED CASE SIZE RANGES

	LENGTH	WIDTH	DEPTH
CS30-RT	8" – 26"	8" – 26"	3" – 26"
	203 – 660 mm	203 – 660 mm	76 – 660 mm
CS30-24RT	20" – 36"	8" – 26"	5" – 26"
	508 – 914 mm	203 – 660 mm	127 – 660 mm
CASE WEIGHT REQUIREMENT - CS30-RT and CS30-24RT			
2 lbs min - 90 lbs max (1 kg min - 41 kg max)			

Pearson's Winning Formula!

- Small footprint minimizes plant floor usage.
- PackML compliant standard
- Flight bar drive provides positive case transfer for a variety of case sizes and weights.
- High speed capability improves plant production and provides future capacity.
- Automatic infeed control provides automatic case indexing into machine.
- Powered case centering ensures tape is applied accurately.
- Powered flights and top case squaring provides properly formed cases sealed each time.
- Powered major flap folding makes the machine more tolerant of heavy wall cases.
- Large case size range.
- Tape fault sensing package.
- Powered major flap folding reduces stress on corrugated cases.
- Expert after-sale service and 24 hour technical support.

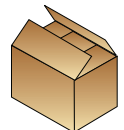

RSC

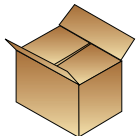

CSSC

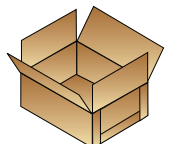

Bliss

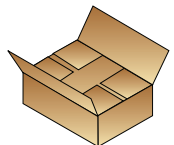

Split Minor Tray

