

Model CS15-T Case Sealer



RSC



CSSC

New Small Footprint Case Sealer top seals cases up to 15 CPM.

Pearson Packaging Systems CS15-T Case Sealer top seals cases with pressure sensitive tape at speeds up to 15 cpm for the full standard case range. The CS15-T is available in mild steel or stainless steel construction.

The CS15-T is a hazard guarded, rugged, compact, and automatic machine capable of top sealing a wide range of RSC & CSSC corrugated cases. The side belt drive with its one sided Compensating Independent Roller System (patented) provides smooth and reliable case transfer for cases up to 13.5 Kg (30 lbs). The Synchronous Drive System eliminates the need for complicated chain tensioning or multiple shafts and gear reducers.

The CS15-T utilizes continuous motion to

achieve 15 cpm across the full standard case range. Faster case speeds are possible on shorter length cases. The CS15-T also utilizes no tool quick change over to different case sizes. Filled cases enter the machine with a minimum of 380mm (15 in) separation. Minor & major flaps are folded and an AB Sealer® Piranha tape head applies tape to the case. The CS15-T comes standard with 24VDC control voltage, UL® Listed Control Panel, Allen-Bradley® PLC, PackML compliance and non-lube bearings.

Like all Pearson products, the CS15-T is backed by Pearson's experienced factory professionals as well as one of the largest teams of PMMI certified regional service technicians in the industry, available 24-hours a day, 7-days a week - worldwide.

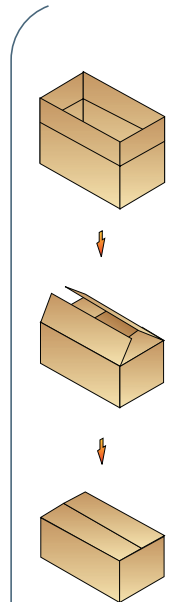

Packaging - Processing
Bid on Equipment
1-847-683-7720
www.bid-on-equipment.com

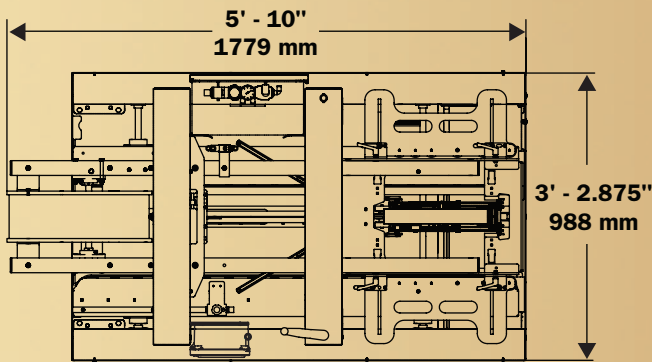

PLAN VIEW

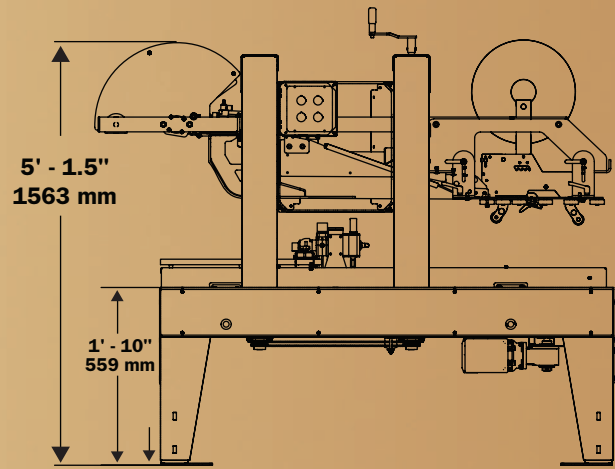

ELEVATION VIEW

0' - 0.625" TO 0' - 6.625"
17 mm TO 168 mm

UTILITY REQUIREMENTS CS15-T

Electrical:

110V single phase or 220V single phase
847 watts (1.31 kVa)

Pneumatic:

0.016 SCF/cycle @ 80 PSI
(0.0005 m³ /cycle @ 551.2 KPa)

Shipping Weight:

700 lbs (318 kg)

ERECTED CASE SIZE RANGES

	LENGTH	WIDTH	OPEN DEPTH*	CLOSED DEPTH
CS15-T	6" - 24" 153 - 609 mm	4" - 16" 102 - 406 mm	5" - 26.5" 127 - 673 mm	3" - 18.5" 76 - 469 mm

Maximum Case Weight is 30lb (13.5 kg)

* Top flaps open, bottom flaps closed. For speeds greater than 15 cpm, please consult the factory.

Pearson's Winning Formula!

- Rugged, compact, continuous motion case sealer.
- 15 cases per minute for the full standard case range with faster speeds possible on shorter case lengths.
- Available in mild steel or stainless steel construction.
- No tool quick change over to different case sizes.
- Compensating Independent Roller System for smooth & reliable case transfer through the machine (patented).
- Synchronous Drive System standard.
- Externally accessible adjustments.
- Allen-Bradley® PLC standard.
- Pneumatic controlled flap kicker.
- Hazard guard package.
- AB Sealer® Piranha Tape Head.
- NEMA 4 electrical enclosure
- Expert after-sale service and 24 hour technical support.

MACHINE SPECIFICATIONS

	LENGTH	WIDTH	HEIGHT
CS15-T	5' - 10" 1778 mm	3' - 3" 984 mm	5' - 2" 1572 mm

