

# Model BE60-C Carrier Erector

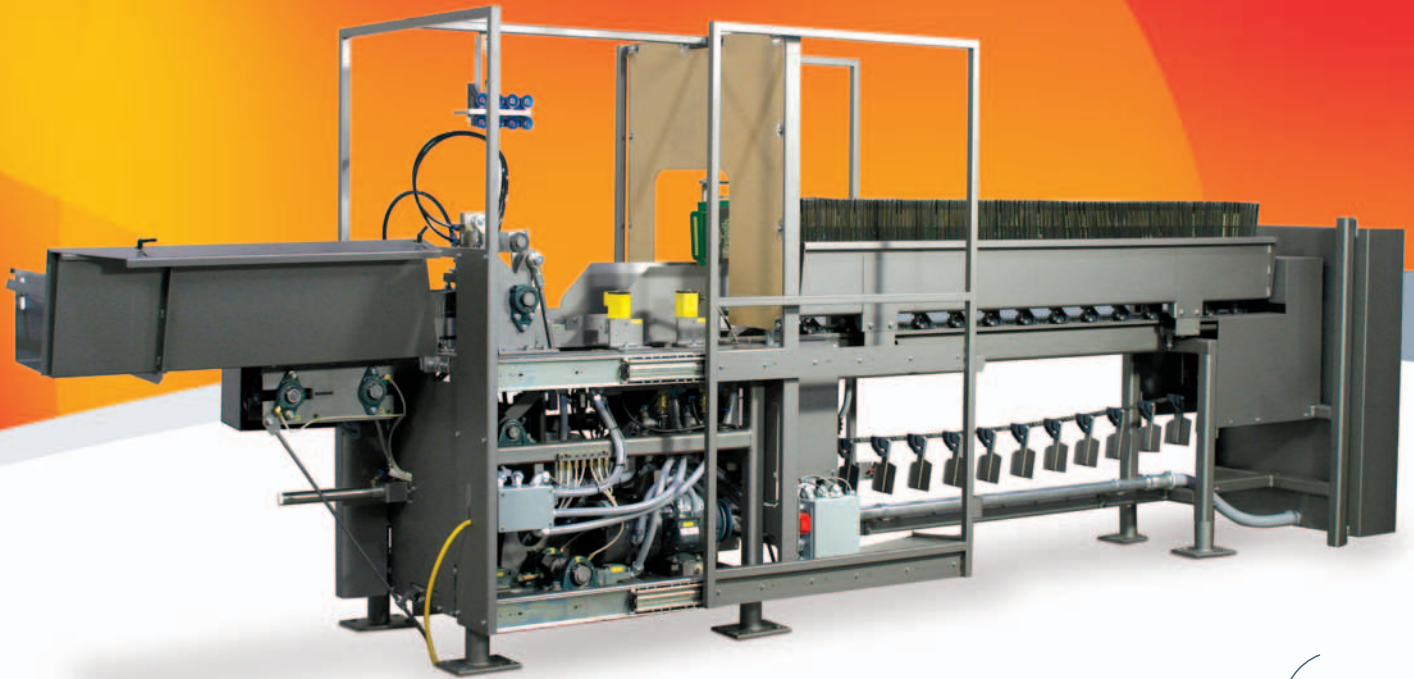

## 60 CPM for Canadian Style Domestic & US Style Export Carriers.

Pearson's BE60-C Carrier Erector is a compact, portable machine that reliably sets up 4 & 6 pack Canadian Style Domestic and US Style Export Carriers at rates up to 60 carriers per minute, depending on size and style.

The BE60-C employs a vacuum feed that effectively deals with difficulties caused by warped carriers or variances in board thickness. Adjustments for the BE60-C are quick & simple and can accommodate a full range of carrier sizes.

The BE60-C comes complete with an acrylic guard package with electrical interlocks, inventory control photoeye at the discharge, UL/CUL® listed control panel and a flighted 6' high capacity magazine.

The flighted high capacity magazine holds a highly visible reservoir of approximately 480 knocked down carriers that are easily loaded without interruption to the production cycle.

The flighted magazine also serves to stabilize the Canadian style carriers while being sent into the body of the machine. An optional 4' magazine for 320 carriers is available for customers with limited floorspace.

Like all Pearson products, the BE60-C is backed by Pearson's experienced factory professionals as well as one of the largest teams of PMMI certified regional service technicians in the industry, available 24-hours a day, 7-days a week - worldwide.

Canadian Style Domestic Carrier

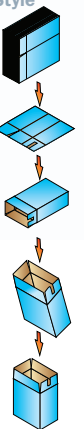

US Style Export Carrier

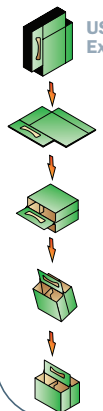

Packaging - Processing

**Bid on Equipment**

1-847-683-7720

[www.bid-on-equipment.com](http://www.bid-on-equipment.com)

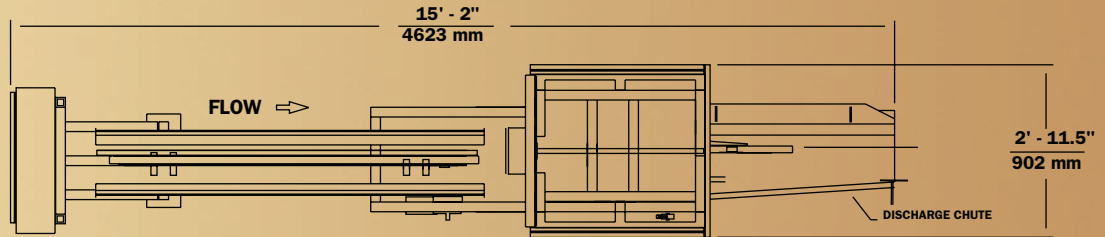

**Plan View**

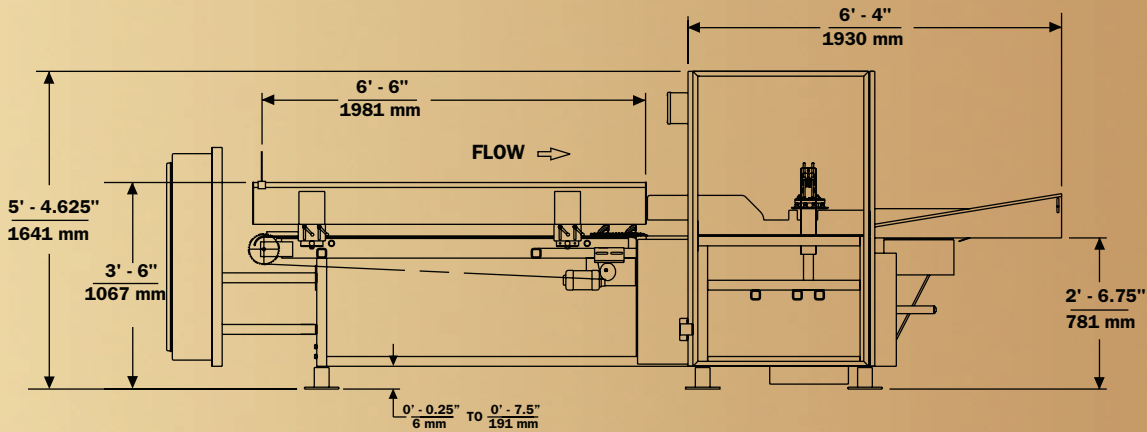

**Elevation View**

### UTILITY REQUIREMENTS BE60-C

**Electrical:**

460V, 3-phase,  
60 Hz Std., 1.2 kVA

**Pneumatic:**

4.25 SCF/Cycle @ 60 PSI  
(0.118 m<sup>3</sup>/cycle @ 551.2 KPa)

Cam Operated Valve  
5.038 SCF/Cycle @ 60 PSI  
(0.141 m<sup>3</sup>/cycle @ 551.2 KPa)

For Continuous Flow  
(Flow assumes hand valve is half open. Double flow for full open.)

**Shipping Weight:**

1700 lbs (765 kg)

### KNOCKED DOWN CARRIER SIZE RANGE

LENGTH	WIDTH	
9.5" - 14"	7.5" - 13"	
241 - 355 mm	191 - 330 mm	

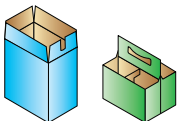

**Packaging - Processing**  
**Bid on Equipment**  
 1-847-683-7720  
[www.bid-on-equipment.com](http://www.bid-on-equipment.com)

