

PAK-RAPID INC.
PACKAGING MACHINES

**Model
AV**

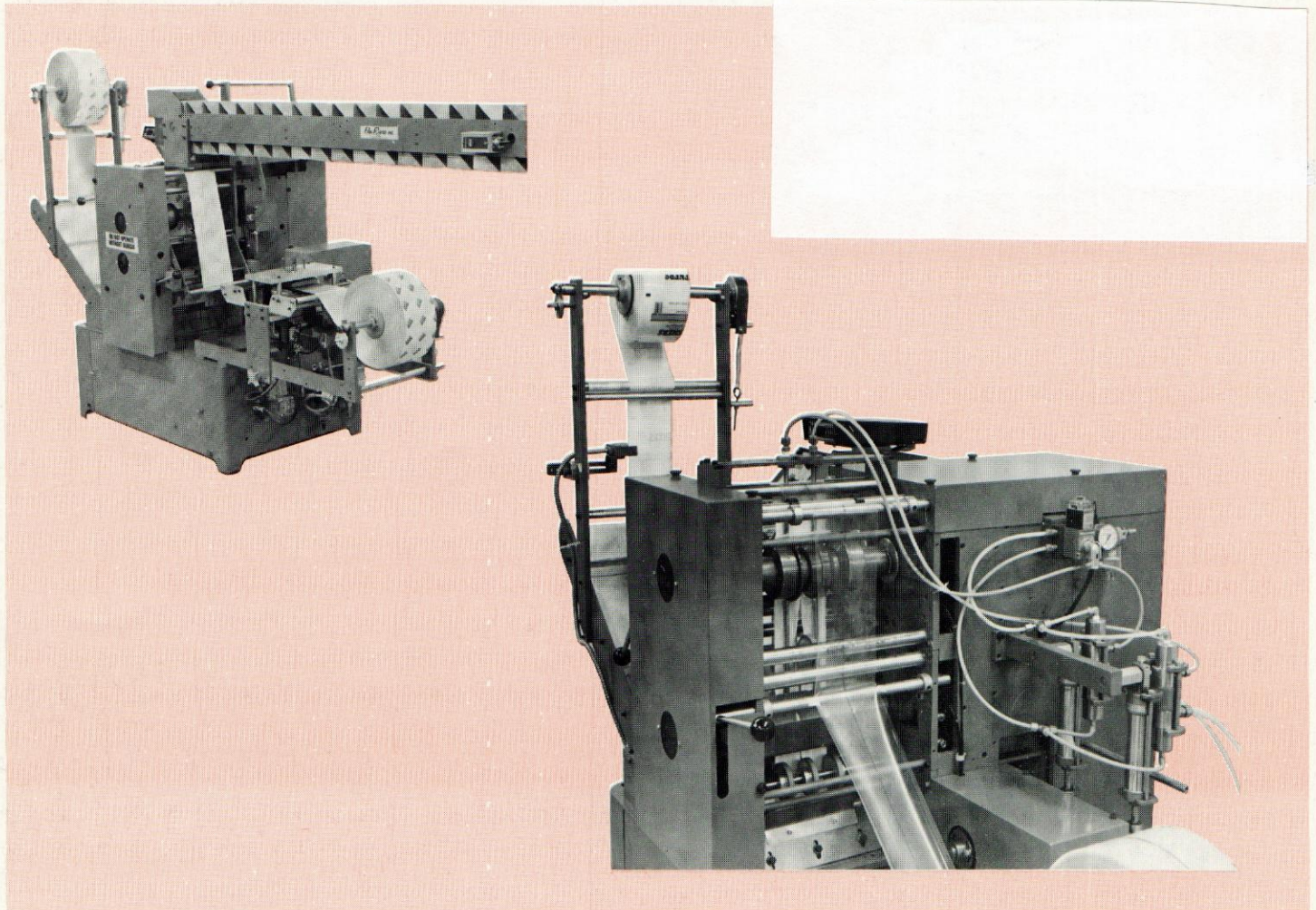

VERTICAL FEED POUCH PACKAGING MACHINE

High speed adjustable Vertical Feed Pouch Packaging Machine for powders, liquids, semi-liquids, granulars, creams, gravies.

Machine can be equipped for single or multiple line operation depending upon product dimensions.

Filling attachments are readily interchangeable for handling different products.

ADAPTABLE FILLERS

- VOLUMETRIC** — Free-flowing powders, granulars, beads, condiments
- AUGER** — Non-free flowing powders, mixes, condiments
- PUMP** — Liquids, creams, gravies

Send us samples of your products and details of your production requirements for a prompt quotation and recommendations.

1050 COLWELL LANE · CONSHOHOCKEN, PA 19428 · (215) 828-3511

SEALING STATION

Adjustable side and cross sealing dies allow for establishing pouch sizes to fit the product. Package sizes are adjustable from 2" to 7" O.D. in width, and from 3" to any required length. Width changes are effected by positioning the side sealing dies to the pouch widths required. Pouch lengths are controlled by electric eye markings or change gears.

Sealing temperatures are accurately controlled within $\pm 3^{\circ}\text{F}$. Each sealing member is equipped with the required number of heaters for efficient sealing and a thermister probe for sensing temperatures. Temperature of individual sealing dies can be adjusted by a control on the panel.

FEATURES

Electric Variable Speed SCR Drive — Operating speeds can be regulated from 0 to 90 packages per minute by dial setting.

Proportional Heat Controls — Accurate heat controls can be regulated for hard-to-seal and military spec. materials.

Central Lubricating System — Provides for the lubrication of main bearings on die shafts.

Overload Release & Knife Safety Clutch — Machine stops instantly in the event of a jam occurring in the sealing dies or cut-off knife.

Photo Registration — Unique registration system synchronizes the cross sealing dies to the registered imprint. Stretching or compensation of film variation is not required thereby requiring minimal operator attention.

OPTIONAL EQUIPMENT

Printers — Ink, ribbon, or roll leaf for random or registered imprinting.

Photo Electric Eye — For one side or front and back registration of preprinted materials.

Batch & Total Counters — For registering count of packages and automatically turning off machine when pre-set count is attained.

*Size and packaging material govern maximum speeds

SPECIFICATIONS

Power requirements — 115/220 volts 60 cycles Single Phase, Three Wire.

Packaging Materials — Any supported heat sealable or cohesive materials including military spec.

Floor Space — 4 ft. long x 3 ft. wide x 6 ft. high.

Weight — Approx. 1300 lbs. depending upon attachments

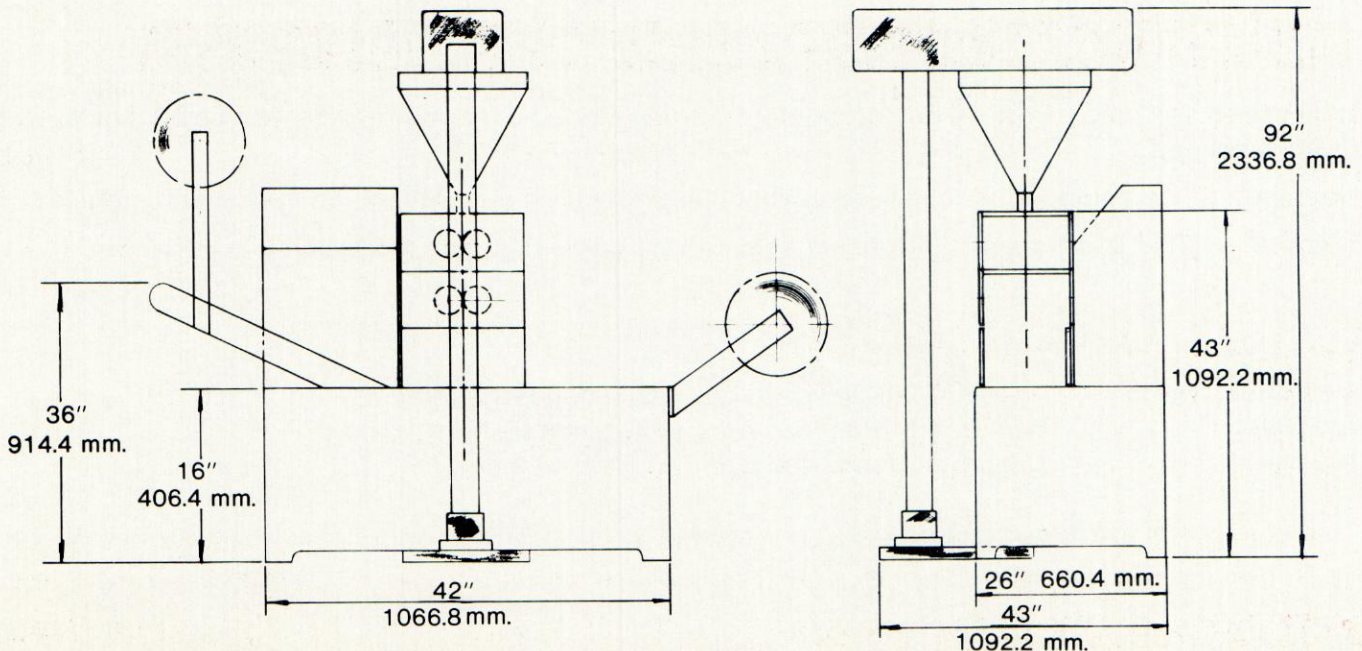

SUPPLEMENT FOR MODEL-AV

The Adjusta-Pak was designed for the packaging of powders, liquids, and granulars. The machine can be equipped with volumetric, auger, piston pump, or other suitable feeders to handle specific products. The machine can also be supplied for multiple row production.

The machine can process any supported heat seal or cold seal packaging material.

The machine is equipped with adjustable dies so that package size changes in both directions can be effected without change parts, in a minimum amount of time.

Because of the simple package size change arrangement, the machine is especially suitable for short run production. Photo electric registration is available for both front and back panel registration.

A large selection of printing attachments and coders is available for imprinting the packaging material.