

# New

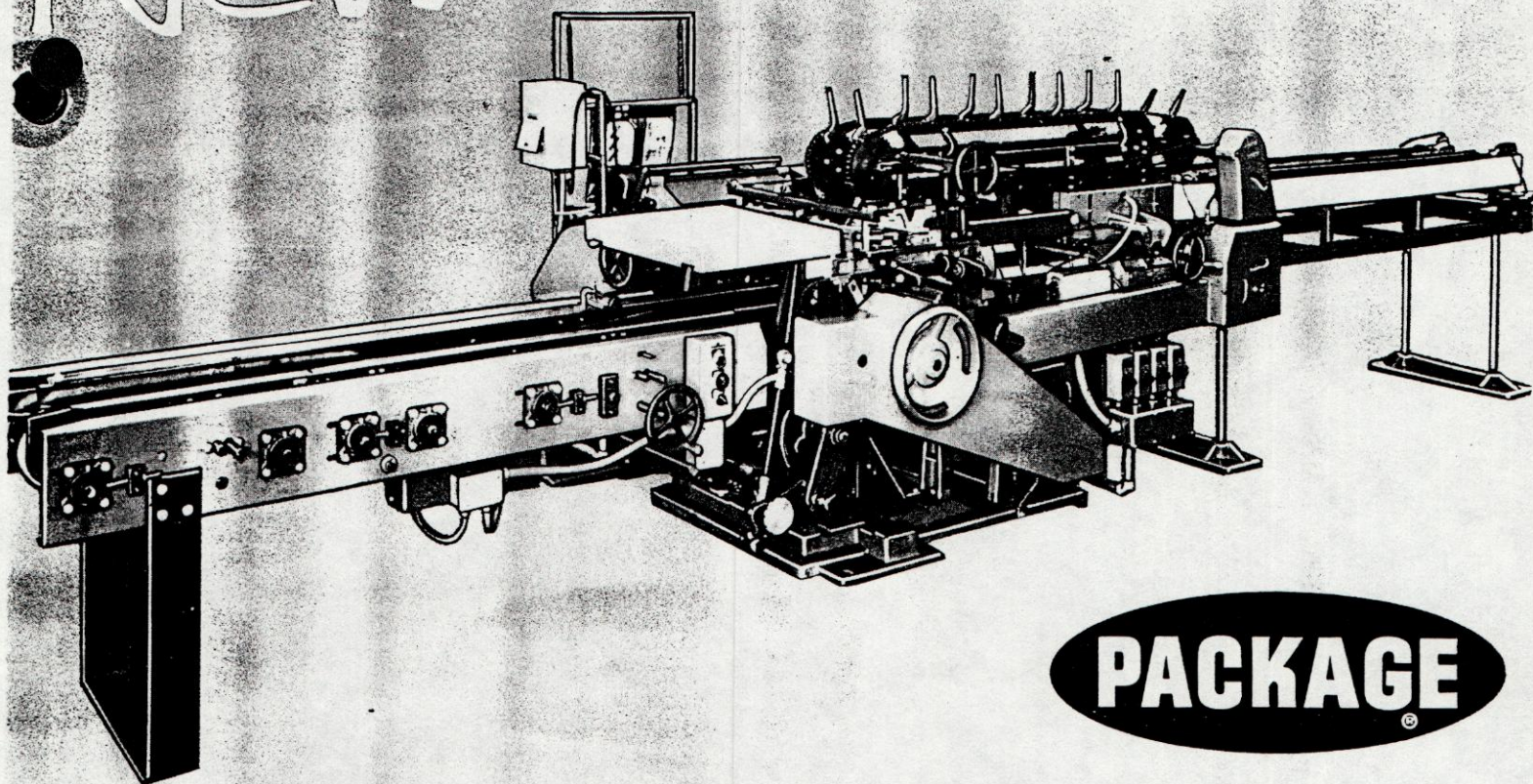

**PACKAGE**®

## Model FA-1H

**HIGH SPEED WRAPPING MACHINE  
for Cellophane, Waxed Paper, Foil or Plain Paper**

The Package FA-1H wrapping machine combines speed and versatility. It will wrap products in cartons, boxes, open trays or flat objects on cardboard at speeds from 65 to 150 packages per minute. A convenient handwheel regulates speed while machine is in motion.

Size changes within the FA-1H's range require minimum effort with easy handwheel adjustments and substitution of readily accessible parts. Wrapping material rolls can be inserted quickly and the automatic infeed has quick change features.

A versatile machine, the FA-1H handles packages from 4" to 12" long, 1 1/8" to 6" wide and 3/8" to 3 1/2" high.

Like all "Package" Machines, the FA-1H is designed and built to give you years of trouble-free service. New cam-operated elevators assure reliable high speed operation. Mechanically operated folders and improved heat controls result in neater folds and better sealing. A centralized lubrication system assures smooth operation.

**PACKAGE MACHINERY COMPANY** East Longmeadow, Massachusetts

PACKAGE

# MODEL FA-1H HIGH SPEED WRAPPING MACHINE

## SPECIFICATIONS

**Speed** — 65 to 150 packages per minute  
Variable speed drive provided

**Size Range** — 4" to 12" long  
1 1/8" to 6" wide  
3/8" to 3 1/2" high

**Wrapping Materials** — Printed or unprinted cellophane, waxed paper, foil, plain paper or glassine.

**Wrapper size** — Roll width-maximum 17 1/4"  
Cut off-maximum 16"  
Maximum dia-roll 16" Core 3"

**Type of fold** — Standard double point fold

**Feed** — Belt feed into in-line automatic feeder. Chain feed will deliver package positively on to elevator. Automatic feeder accommodates full machine size range.

**Discharge** — Either 7 ft. side belt or 3 ft. bottom belt.

**Motor** — 1 H.P. 1750 RPM

**Heaters** — (220 volt only) — Waxed paper — 13,000 watts  
Cellophane — 9,000 watts

**Optional Equipment Available** — Electric eye unit. Code dater, Automatic splicer, Easy opening tape.

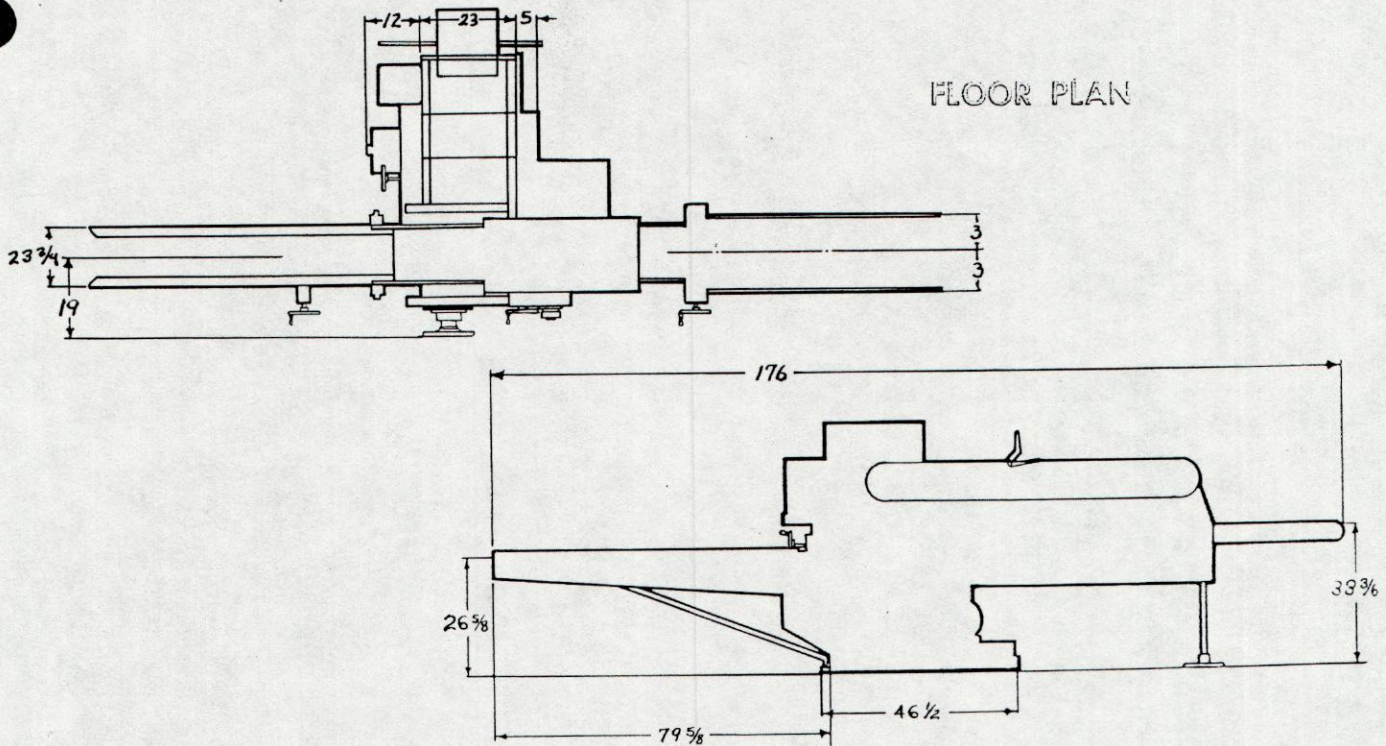

FLOOR PLAN

**PACKAGE**