



Variety Slicer

Key Features:

- Slices virtually all varieties of bread cleanly and quickly
- Compact, sturdy design is easy to use
- Automatically holds bread in place during slicing
- Blade advantages:
 - Uses the lowest cost replacement blades in the industry, contributing to low cost of ownership
 - Easily replaceable, independently mounted, rust - resistant blades
 - Blade replacement only takes one hour of labor, the lowest in the industry
- Provides years of efficient, trouble-free operation, with minimal maintenance required
- Bagging scoop standard
- Recommended for slicing approximately 150 loaves per day



The information contained herein is correct to the best of our knowledge. The recommendations or suggestions are made without guarantee or representation as to results. Freedom from any patent owned by Oliver Packaging and Equipment or other is not to be inferred.

Above specifications subject to change without notice



Manufactured in the U.S.A.



Oliver Packaging & Equipment Company
 511 Sixth Street NW • Grand Rapids, MI 49504
 (800) 253-3893 • (616) 356-2950 • www.oliverquality.com

Packaging - Processing
Bid on Equipment
1-847-854-8577
www.bid-on-equipment.com



Variety Slicer

SPECIFICATIONS:

Motor:

1/2 H.P., single phase, 60Hz, 115 VAC, 7 AMPS.
Special electrics also available

Capacities:

16" (406mm) long X 10 1/2" (267mm) wide X 3 1/2" (90mm) high to 6" (152mm) high

Slice Spacing (thickness):

Standard: 3/8" (10mm), 7/16" (11mm), 1/2" (13mm)

Also available (at extra cost): 1/4" (6.3 mm) 5/16" (8mm), 9/16" (14mm), 5/8" (16mm), 3/4" (19mm), 7/8" (22mm) or 1" (25mm), 1.5" (38mm)

Lubrication:

Sealed and grease-packed ball bearings contribute to smooth, quiet operation

Finish:

Durable white powder coat finish to resist rust and corrosion

Dimensions:

	Floor Model	Countertop Model
Shipping Weight:	300 lbs. (135kg)	260 lbs. (117kg)
Net Weight:	250 lbs. (113kg)	240 lbs. (109kg)
Width:	24" (610mm)	24 1/4" (616mm)
Depth:	24" (610mm)	24" (610mm)
Height	47" (1194mm)	26.5" (67.mm)

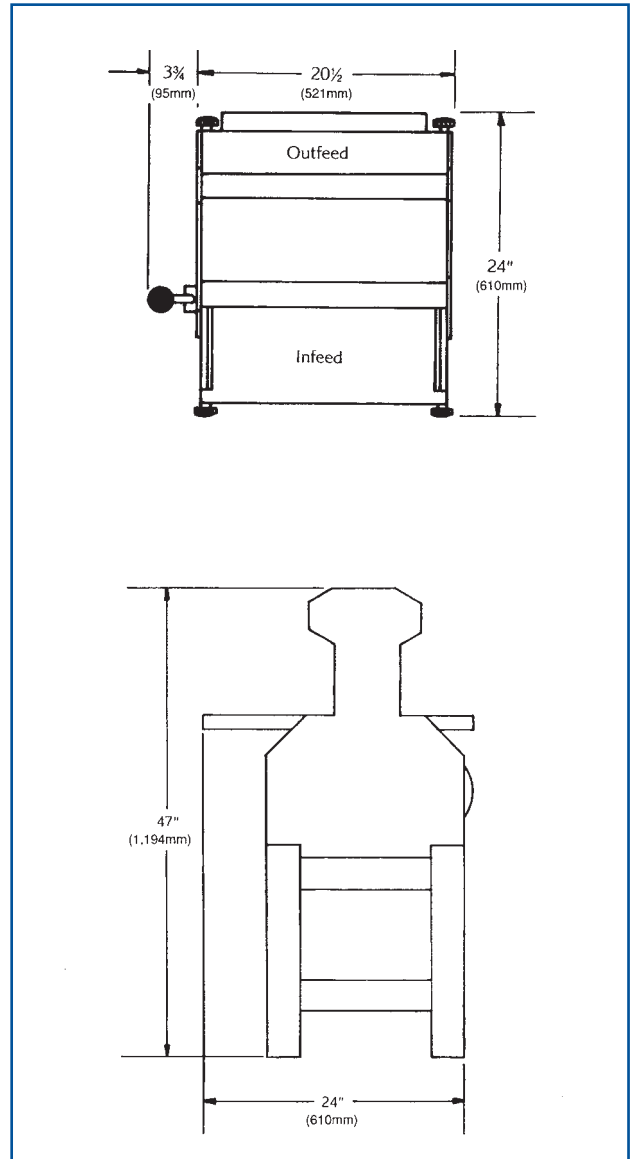

The information contained herein is correct to the best of our knowledge. The recommendations or suggestions are made without guarantee or representation as to results. Freedom from any patent owned by Oliver Packaging and Equipment or other is not to be inferred.

Above specifications subject to change without notice

Manufactured in the U.S.A.



Oliver Packaging & Equipment Company
511 Sixth Street NW • Grand Rapids, MI 49504
(800) 253-3893 • (616) 356-2950 • www.oliverquality.com

Packaging - Processing
Bid on Equipment
1-847-854-8577
www.bid-on-equipment.com