



Grand Rapids, Michigan, U.S.A. 49504-5298

USER'S OPERATING AND INSTRUCTION MANUAL

MODEL 738

MINI CHIP SLICER

0738S20000-CV



INDEX

<u>Section Description</u>	<u>Document No.</u>	<u>Page No.</u>
SAFETY INSTRUCTIONS -----	0738S20002 -----	1-1
DESCRIPTION/SPECIFICATIONS -----	0738S20016 -----	2-1
INSTALLATION INSTRUCTIONS -----	0738S20004 -----	3-1
OPERATING INSTRUCTIONS -----	0738S20017 -----	4-1
TROUBLESHOOTING -----	0758S20006 -----	5-1
CLEANING AND MAINTENANCE -----	0758S20018 -----	6-1
Removing the Blade Cartridge -----		6-1
Cleaning -----		6-4
Replacing the Blade Frames -----		6-5
Changing the Blades -----		6-7
Lubrication -----		6-8
General Cleaning -----		6-8
 REPLACEMENT PARTS SECTION		
MAIN FRAME -----	0758S20019 -----	7-1
Drawing -----		7-2
ELECTRICAL -----	0758S20020 -----	8-1
Drawing -----		8-1
Parts List -----		8-2
DRIVE COMPONENTS -----	0758S20021 -----	9-1
SLICE PARTS/COVERS -----	0758S20022 -----	10-1
Drawing -----		10-1
Parts List -----		10-2
WIRING DIAGRAM 1-60-120 -----	0738S20013 -----	12-1
WARRANTY -----	GEN 040225	
WARRANTY PROCEDURE -----	GEN 040226	
RETURNED PARTS POLICY -----	GEN 040227	



SAFETY INSTRUCTIONS

WARNING

VARIOUS SAFETY DEVICES AND METHODS OF GUARDING HAVE BEEN PROVIDED ON THIS MACHINE. IT IS ESSENTIAL HOWEVER THAT THE MACHINE OPERATORS AND MAINTENANCE PERSONNEL OBSERVE THE FOLLOWING SAFETY PRECAUTIONS. IMPROPER INSTALLATION, MAINTENANCE, OR OPERATION OF THIS EQUIPMENT COULD CAUSE SERIOUS INJURY OR DEATH.

1. Read this manual before attempting to operate your machine. Never allow an untrained person to operate or service this machine.
2. Connect the machine to a properly grounded electrical supply that matches the requirements shown on the electrical specification plate and follow all specifications of local electrical codes.
3. Disconnect and lock-out the machine from the power supply before cleaning or servicing.
4. Check and secure all guards before starting the machine.
5. Observe all caution and warning labels affixed to the machine.
6. Use only proper replacement parts.
7. Do not wear loose fitting clothing or loose hair when working near this machine. Shirt tails should be tucked in.
8. Wear proper, personal, protective, safety equipment.
9. Keep Hands away from the moving parts of this machine while it is in operation.
10. In addition to these general safety instructions, please follow the more specific safety instructions as specified in the operating instruction manual.
11. The on/off switch is marked with international symbols for on and off. See below.



ON

OFF



DESCRIPTION/SPECIFICATIONS

Description

The Model 738 Mini Chip Slicer is a compact, countertop slicer designed to reprocess shrink - specifically bagels and baguettes - into a marketable bakery/foodservice product. Designed with reciprocating blade technology, the Mini Chip Slicer easily slices through day-old bagels and baguettes.

The Model 738 Mini Chip Slicer is constructed of stainless and painted steel. Easy to clean, the Mini Chip Slicer food contact surfaces - infeed cover, pusher, handle, and blade cartridge - can be removed without the use of tools for cleaning and sanitizing in a dishwasher. Blade changes are simple: simply remove the blade cartridge, replacing it with an OEM cartridge. No tools or service company required.

Specifications

Space Requirements:

Model 738 (All Dimensions are Approximate)

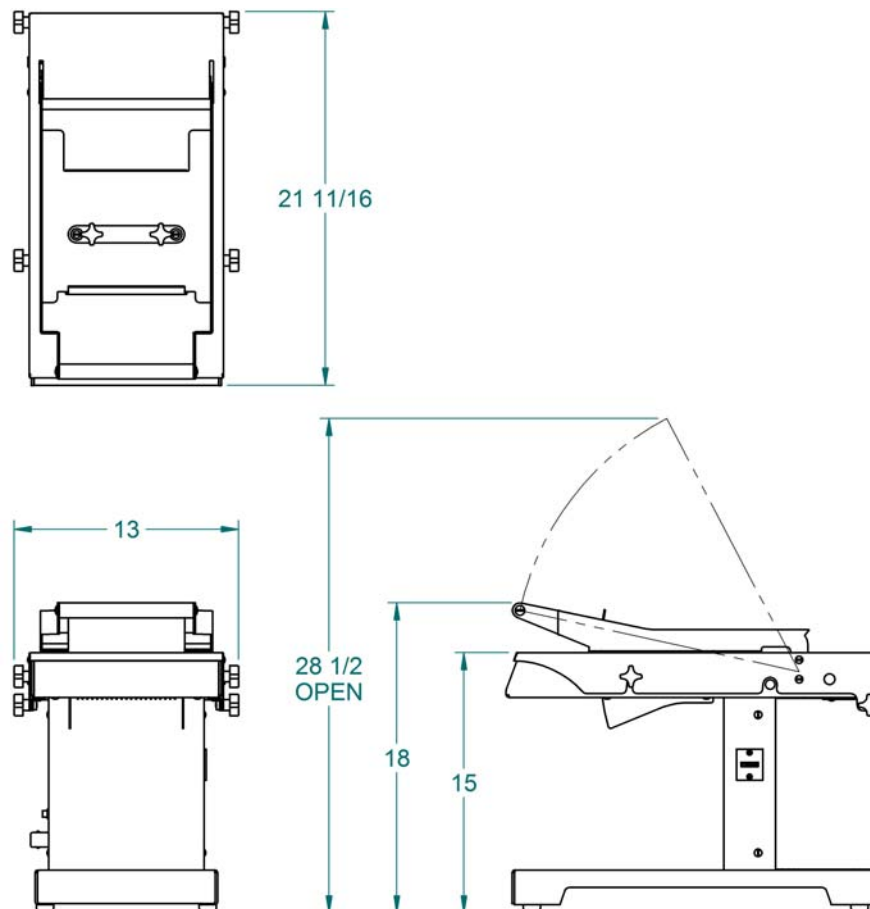



Oliver Packaging & Equipment Company
511 Sixth Street NW • Grand Rapids, MI 49504

(800) 253-3893
www.oliverquality.com

Product Capacities:

Length 6 inches
Width 6 inches
Height 2 inches

Standard Electrical Options: (Others consult factory)

1 phase, 60 Hz, 120VAC, 2 Amps.

Shipping Weight:

100 lbs. (approximate)

Net Weight:

80 lbs. (approximate)



Oliver Packaging & Equipment Company
511 Sixth Street NW • Grand Rapids, MI 49504

(800) 253-3893
www.oliverquality.com

INSTALLATION INSTRUCTIONS

Before starting the Installation process make sure you observe the following caution notes.

CAUTION

THE SLICER IS HEAVY, USE PROPER TECHNIQUE WHEN LIFTING OR MOVING.

Select a location for your slicer which has a substantial mounting surface and which has electrical service compatible with the load the machine will place on it as indicated on the electrical data plate of the machine. Position the machine while it is still in its packaging as close as possible to the desired end location.



OPERATING INSTRUCTIONS

WARNING

ALWAYS USE CARE WHENEVER WORKING NEAR THE CUTTING KNIVES.

To operate the slicer, follow these simple steps:

1. Power unit on and lift the handle. The unit will automatically shut off.
2. Place the product atop the blades towards the front of the cutting area.
3. Using the handle, apply slight pressure in a downward motion until the handle comes to a stop. Repeat steps 1-3.
4. When finished, power the unit off.

NOTE

THE UNIT WILL CONTINUE TO RUN UNLESS THE HANDLE IS LIFTED TO THE STARTING POSITION. PLEASE REMEMBER TO POWER OFF THE UNIT WHEN SLICING IS COMPLETE.

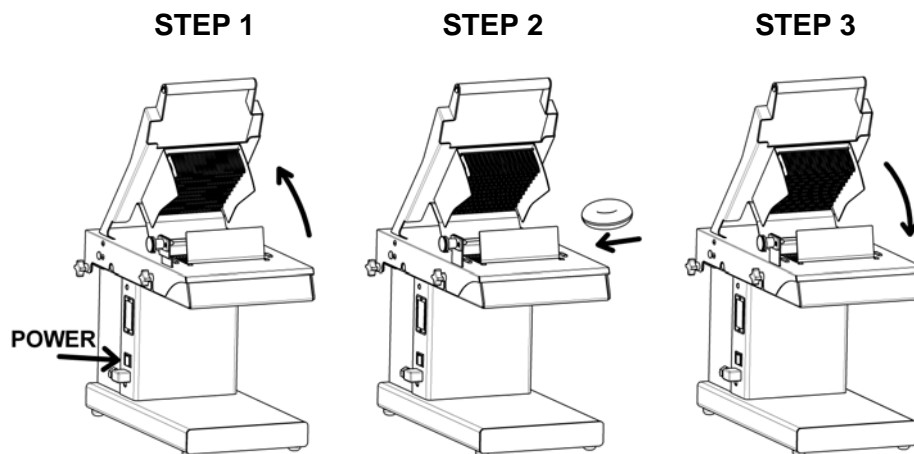



TROUBLE SHOOTING

WARNING

ALWAYS DISCONNECT THE SLICER FROM THE POWER SUPPLY BEFORE ATTEMPTING ANY TYPE OF MAINTENANCE TASK, INCLUDING TROUBLESHOOTING.

Slicer will not start

- The machine is not plugged in.
- There is no power at the outlet.
- The cover is not on correctly. The cover has an interlocking mechanism that allows the unit to operate only if the cover is on.
- Broken wire or disconnected terminals.
- The switch actuator cam is not contacting the switch. Lift the cover and adjust the screw with a flat head screw driver.

Pusher interference when slicing product

- Loosen pusher and adjust side to side to make sure there is no interference.
- Blade frame is not correctly placed on slide blocks.
- Pusher blades are bent or damaged. Contact dealer or factory.

Extreme effort needed to slice product

- Blades are dull. Contact dealer or factory for replacements.
- Product is too stale or old. The slicer is designed to be most efficient with slicing fresh or day old product.



CLEANING AND MAINTENANCE

WARNING

ALWAYS UNPLUG THE SLICER BEFORE PERFORMING ANY TYPE OF MAINTENANCE TASK.

To prepare your unit for cleaning please refer to the pictorial below for step by step instructions.

REMOVING THE BLADE CARTRIDGE

1. Loosen the (2) two thumb screws on the outside of the machine, tip the cover assembly back as shown in figure A. Lift the cover props on each side of the frame securely hold the cover open as shown in figure B.



Figure A

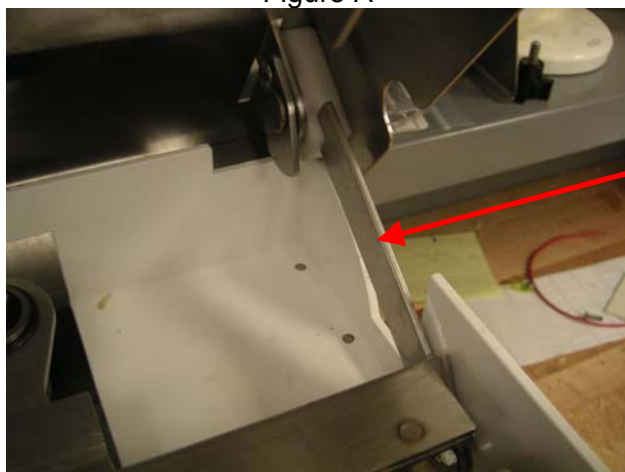

Figure B



2. Loosen and remove the (4) thumbscrews atop the post hold down blocks (Fig. A) and adjust the drive assembly so that the blade frame cartridge is in the closed position as shown below (Fig. B). This is done by turning the knob on the drive assembly so that the channels on the blade frames are close together.

NOTE: The protective blade cover will only fit on the cartridge when it is in the closed configuration. This helps with the cleaning and re-assembly processes.

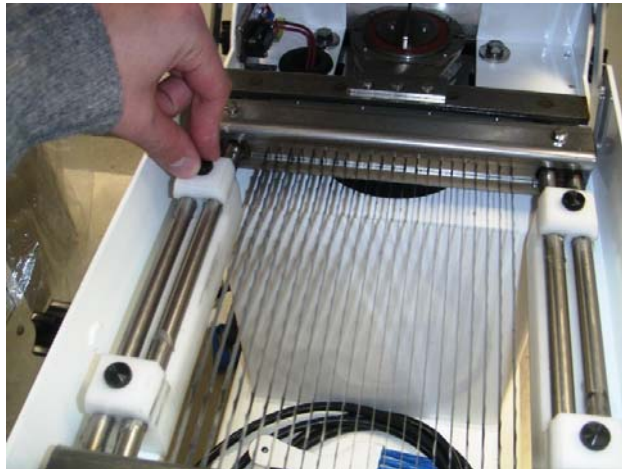

Figure A

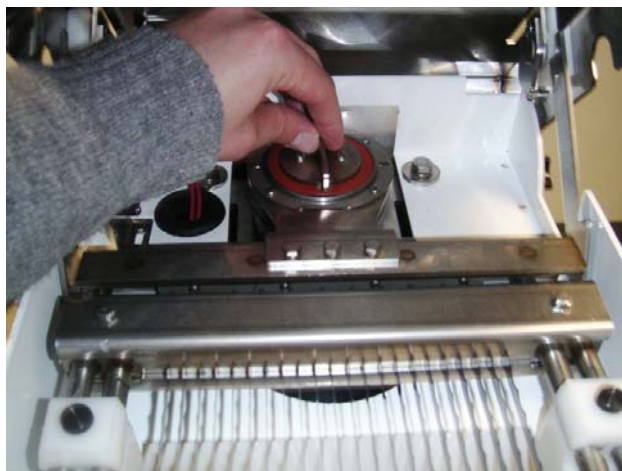

Figure B

CAUTION

USE CAUTION WHILE ADJUSTING THE DRIVE ASSEMBLY. THE BLADES ARE EXPOSED AND VERY SHARP.



Oliver Packaging & Equipment Company
511 Sixth Street NW • Grand Rapids, MI 49504

(800) 253-3893
www.oliverquality.com

3. Place the protective blade cover atop the blade cartridge by hooking the cover around the pin plate near the drive assembly.

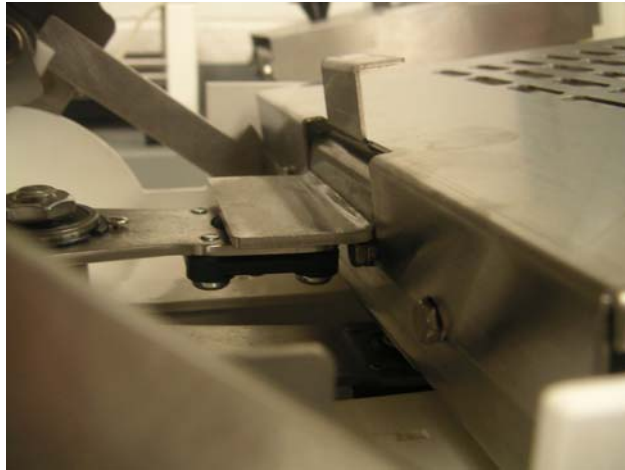

4. Lay the cover down on top of the blade cartridge and fasten with the thumb screw to the blade cartridge by threading the thumb screw into the hole provided.





Oliver Packaging & Equipment Company
511 Sixth Street NW • Grand Rapids, MI 49504

(800) 253-3893
www.oliverquality.com

5. To remove the protected blade frame cartridge simply grip the front of the assembly and the tab provided on the cover and pull up.



WARNING

**NEVER REMOVE BLADE FRAME ASSEMBLY WITHOUT PROTECTIVE GUARD.
BLADES ARE EXTREMELY SHARP AND IF HANDLED INCORRECTLY MAY
RESULT IN SERIOUS INJURY.**

CLEANING

Now that the blade frames have been safely removed you can now proceed with removing any crumb deposits within the machine. A brush, compressed air, or a vacuum are helpful tools for this task.



REPLACING THE BLADE CARTRIDGE

6. Make sure that the drive assembly is in the correct position as shown below.

NOTE: The blade cartridge will only fit back into the machine with the drive assembly in the correct configuration below. The Bearing holes need to be at the position nearest each other.

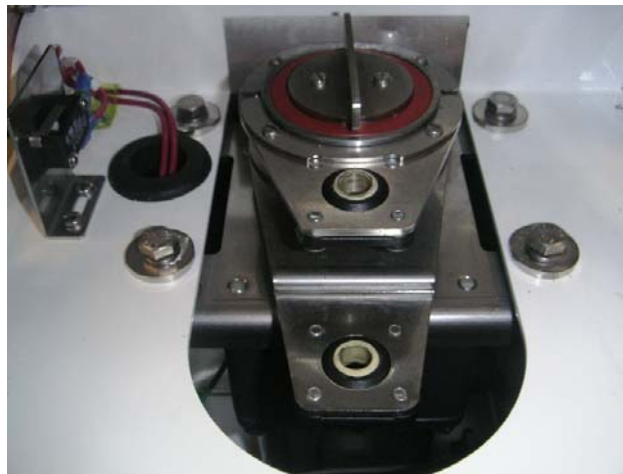

CORRECT



INCORRECT



Oliver Packaging & Equipment Company
511 Sixth Street NW • Grand Rapids, MI 49504

(800) 253-3893
www.oliverquality.com

7. With the protective blade guard in place locate the center of the bearings in the drive assembly with the pin plates attached to the blade cartridge.



8. Once the drive assembly has been located, place the blade cartridge posts in the tracks on the base assembly. Apply slight pressure to the front and rear of the blade cartridge to ensure the proper fit in to the drive assembly and slide blocks. You can now replace the post hold down blocks that you set aside in step 5.
9. Remove the protective blade cover by loosening the thumb screw and unhooking from the pin plate.

NOTE: The cover assembly will not fit on the unit if the protective blade cover is left in place.





Oliver Packaging & Equipment Company
511 Sixth Street NW • Grand Rapids, MI 49504

(800) 253-3893
www.oliverquality.com

10. Lower the cover assembly by placing one hand on the front of the cover and placing both of the cover props in their closed position. Gently lower the cover assembly until it stops.



11. Lastly, after the cover has been lowered into position firmly tighten all thumb screws around the perimeter of the unit.



CHANGING THE BLADES

Oliver Packaging and Equipment suggests that blades not be changed in the field due to the potential for injury. We offer a blade frame cartridge exchange program for when blades become dull. Please contact your dealer or the Oliver service department.



Oliver Packaging & Equipment Company
511 Sixth Street NW • Grand Rapids, MI 49504

(800) 253-3893
www.oliverquality.com

LUBRICATION

WARNING

ALWAYS DISCONNECT THE SLICER FROM THE POWER SUPPLY BEFORE ATTEMPTING ANY TYPE OF MAINTENANCE TASK.

Oliver suggests a vegetable based aerosol product be used to gently coat the blades on occasion. Once a month put a drop of a food approved lubricant on the plastic slide blocks on the inside of the unit. This will increase the longevity of the internal parts of your slicer.

NOTE

NEVER OIL OR GREASE THE MOTOR.

GENERAL CLEANING

Use a mild detergent solution to clean the exterior surfaces. Periodically remove all covers and brush or blow, (if compressed air is available), all foreign material from all surfaces, especially moving parts.



Oliver Packaging & Equipment Company
511 Sixth Street NW • Grand Rapids, MI 49504

(800) 253-3893
www.oliverquality.com

MAIN FRAME

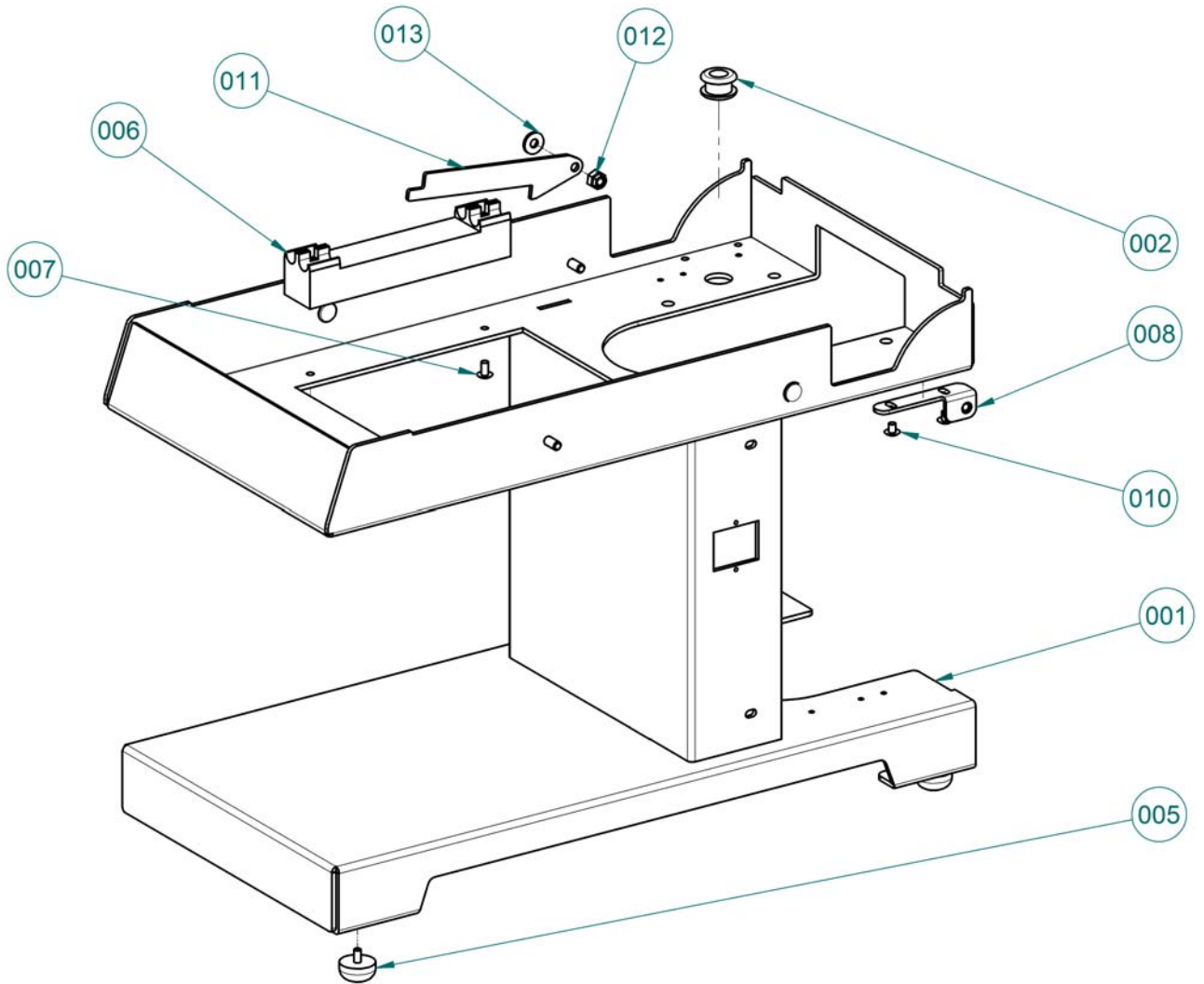



Oliver Packaging & Equipment Company
511 Sixth Street NW • Grand Rapids, MI 49504

(800) 253-3893
www.oliverquality.com

MAIN FRAME PARTS LIST

<u>ITEM NO</u>	<u>PART DESCRIPTION</u>	<u>PART NUMBER</u>
001	Base	0738-0002-1
002	Grommet-Rubber	5767-1207
003*	Nut-10-24 Stainless Acorn	5832-0585
004*	Washer-#10 Spring Lock Stainless	5851-9355
005	Bumper-Rubber w/ Screw	5902-0035
006	Block-Guide	0738-0003-1
007	Screw-10-24 x 3/8 Stainless Truss	5843-5384
008	Bracket-RH Cover Attachment	0738-0004-0001
009*	Bracket-LH Cover Attachment	0738-0004-0002
010	Screw-10-24 x 1/4 Stainless Truss	5843-5383
011	Plate-Prop	0738-0005-1
012	Nut-1/4-20 Stainless Locking	5831-9087
013	Washer-1/4 Flat Stainless	5851-9304

*Items not shown

FOR SERVICE PARTS CALL OLIVER PACKAGING & EQUIPMENT @ 800-253-3893



ELECTRICAL PARTS

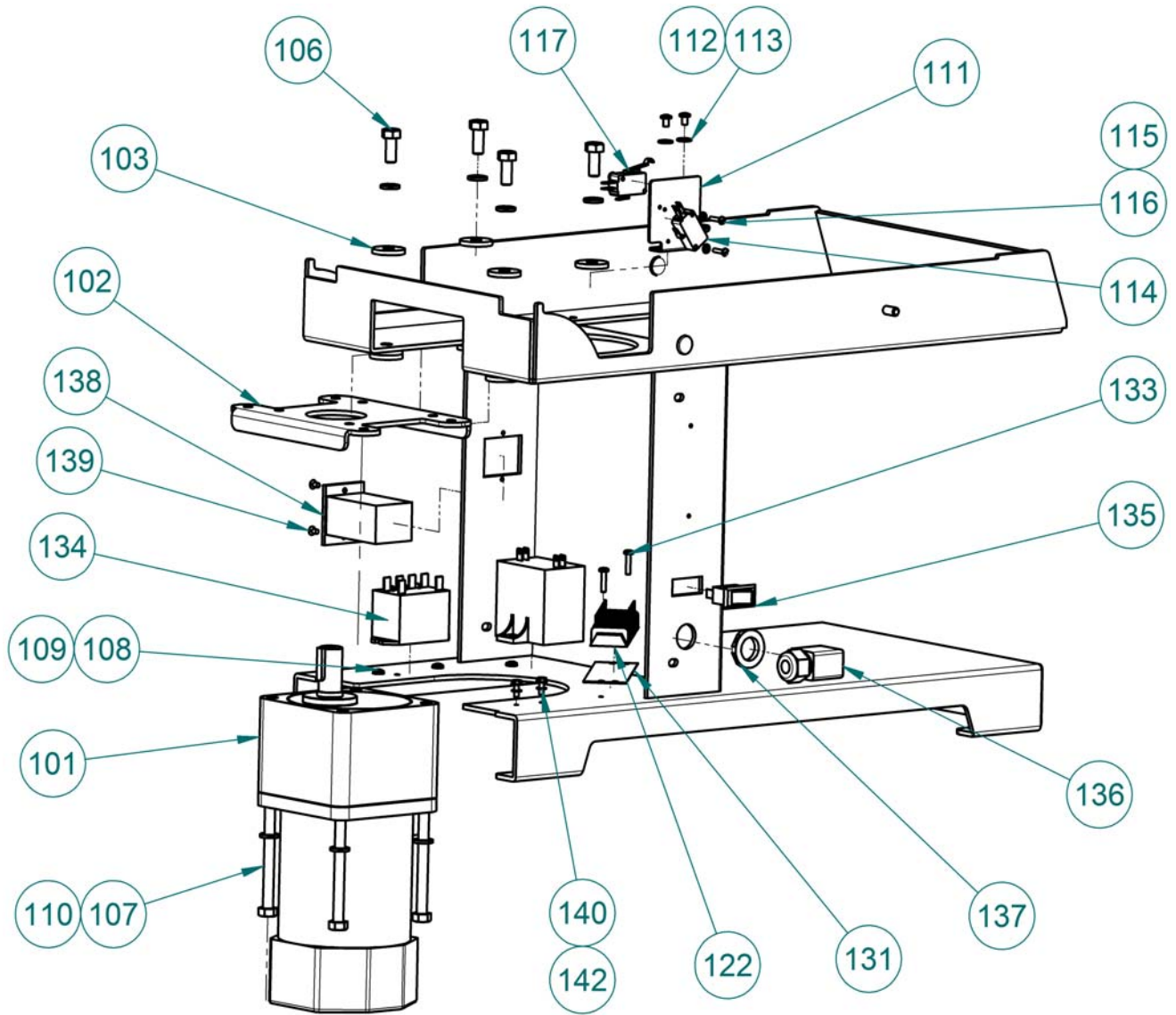



Oliver Packaging & Equipment Company
511 Sixth Street NW • Grand Rapids, MI 49504

(800) 253-3893
www.oliverquality.com

ELECTRICAL PARTS LIST

<u>ITEM NO</u>	<u>PART DESCRIPTION</u>	<u>PART NUMBER</u>
101	Assembly-Motor Cord	0738-25505K
102	Plate-Motor Mount	0738-0045
103	Spacer	0738-0046
106	Screw-5/16-18 x 3/4 Stainless Hex	5843-1028
107	Screw-5/16-18 x 3 1/2 Stainless Hex	5843-1039
108	Screw-8-32 x 5/16 Stainless Pan	5843-5552
109	Washer-#8 Shake Proof Stainless	5851-9130
110	Washer-5/16 Lock Stainless	5851-9358
111	Mount-Switch	0738-0008
112	Screw-8-32 x 1/4 Stainless Pan	5843-5551
113	Washer-#8 Flat Stainless	5851-8108
114	Switch-SM Basic w/ Roller	5757-8002
115	Screw-4-40 x 1/2 Stainless Pan	5843-5524
116	Washer-#4 Shake Proof Stainless	5851-9127
117	Switch-SM Basic	5757-8001
122	Block-Terminal 8 Row	5770-7451
131	Strip-Marker 8 Row	5770-7328
133	Screw-M3.5 x 16mm Stainless Pan	8843-2265
134	Relay	5749-8027
135	Switch-Rocker	5757-3314
136	Bushing-Strain Relief 90°	5765-1010
137	Nut-PG-11 Plastic Lock	5766-7786
138	Counter-5 Digit Mini	5712-9080
139	Screw-6-32 x 1/4 Stainless Truss	5843-5360
140	Screw-6-32 x 3/8 Green Grounding	5841-9501
142	Washer-#6 Shake Proof Stainless	5851-9129

FOR SERVICE PARTS CALL OLIVER PACKAGING & EQUIPMENT @ 800-253-3893



DRIVE COMPONENTS

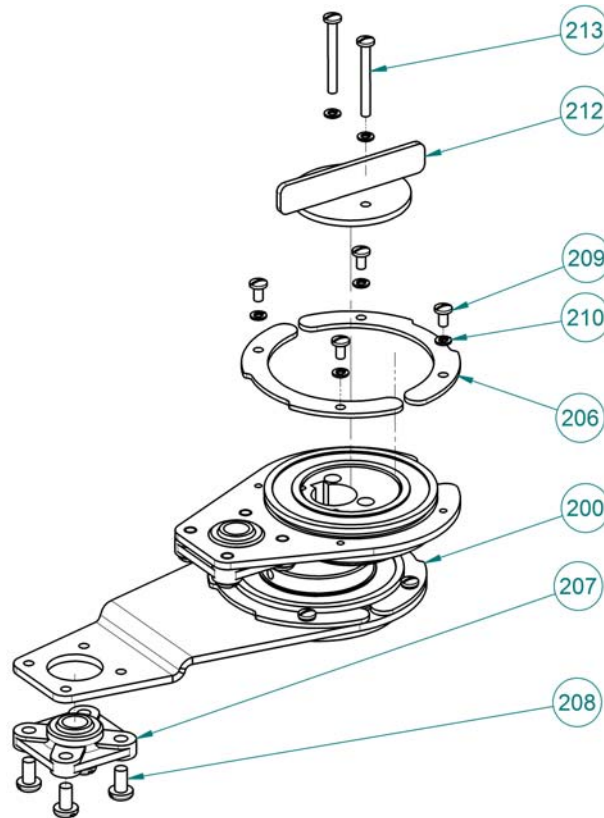

DRIVE COMPONENTS PARTS LIST

ITEM NO	PART DESCRIPTION	PART NUMBER
200*	Assembly-Drive	0738-25012K
206	Clip-Bearing	0738-0049
207	Bearing-10mm Spherical Flange Mount	5251-3591
208	Screw-10-24 x 3/8 Stainless Pan	5843-5384
209	Screw-6-32 x 1/4 Stainless Pan	5843-5541
210	Washer-#6 Lock Stainless	5851-9353
212	Knob	0738-0051
213	Screw-6-32 x 1 ¼ Stainless Pan	5843-5547

Replacements for 200 are ordered assembled with fasteners. Parts may not be substituted within the assembly other than those called out.

FOR SERVICE PARTS CALL OLIVER PACKAGING & EQUIPMENT @ 800-253-3893



SLICE PARTS/COVERS

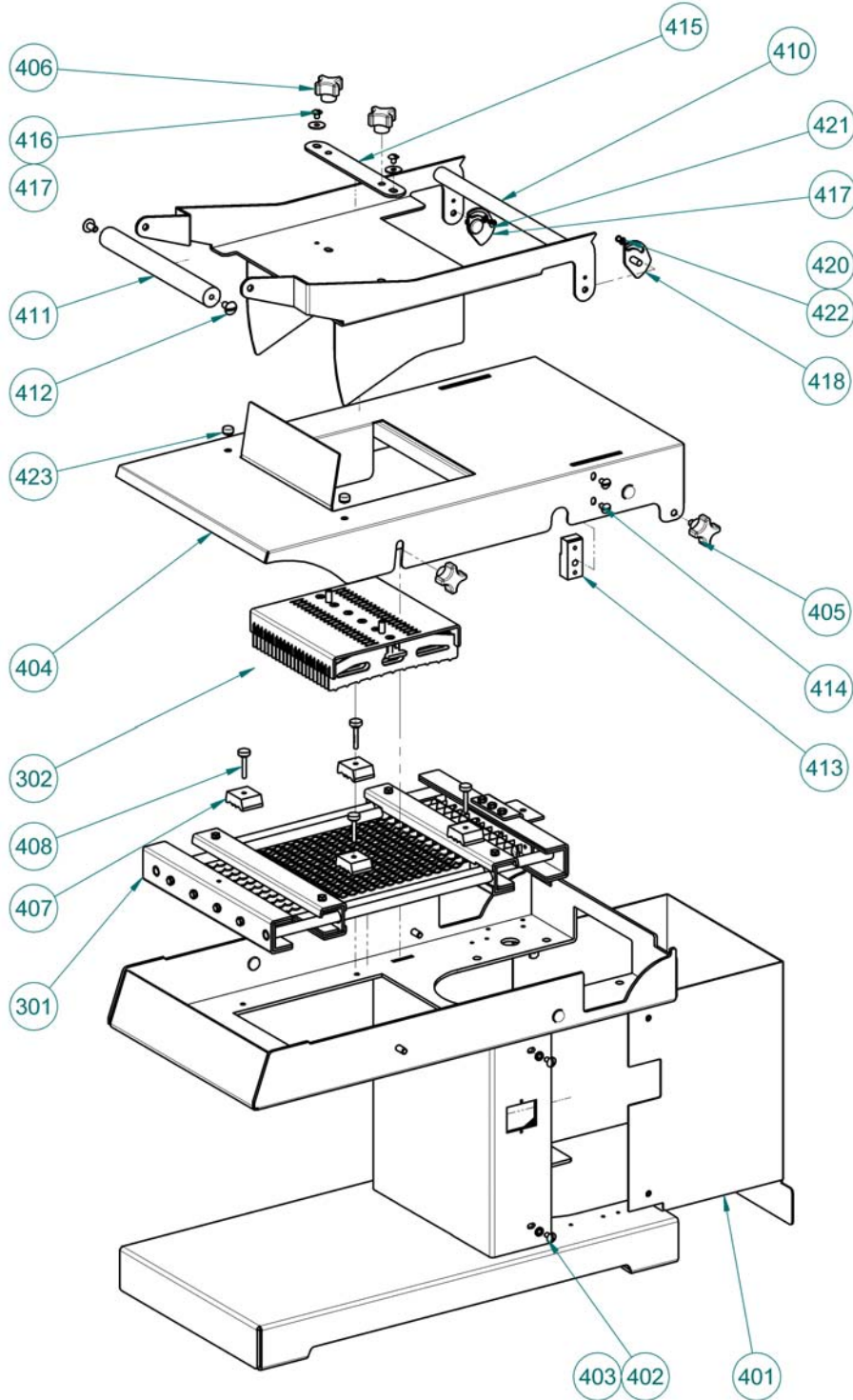



SLICE PARTS/COVERS PARTS LIST

<u>ITEM NO</u>	<u>PART DESCRIPTION</u>	<u>PART NUMBER</u>
301	Cartridge-Blade Frame	0738-25XXXK
302	Assembly-Pusher	0738-25XXXK
303	Cover-Blade Frame Safety	0738-0024K
401	Cover-Motor	0738-0033-1
402	Screw-10-24 x 3/8 Stainless Truss	5843-5384
403	Washer-#10 Shake Proof Stainless	5851-9394
404	Cover-Base	0738-0034-1
405	Screw-Clamp	4560-2508-1106
406	Knob-1/4-20 4 Prong Plastic	5911-7034
407	Block-Top Guide	0738-0052
408	Screw-8-32 x 1 Stainless Thumb	0738-25504K
410	Assembly-Handle w/ Guard	0738-0038-1
411	Handle	0738-0039
412	Screw-1/4-20 x 1/2 Stainless Truss	5843-5412
413	Block-Handle Hinge	0738-0040
414	Screw-10-24 x 3/8 Stainless Truss	5843-5384
415	Plate-Pusher Centering	0738-0041
416	Screw-10-32 x 1/4 Stainless Truss	5843-5390
417	Washer-#10 Fender Stainless	5851-9324
418	Plate-RH Cover Cam	0738-0042-0001
419	Plate-LH Cover Cam	0738-0042-0002
420	Screw-8-32 x 1/4 Stainless Round	5843-5232
421	Screw-8-32 x 1/4 Stainless Tamper	5843-5650
422	Washer-#8 Spring Lock Stainless	5851-9354
423	Bumper-Press In	5902-0023

*Items 301 and 302 are replaced fully assembled. Specify slice thickness when ordering.

**Item 303 is provided with each blade frame assembly and is used for safe handling. Not Shown.

FOR SERVICE PARTS CALL OLIVER PACKAGING & EQUIPMENT @ 800-253-3893



WIRING DIAGRAM 1-60-120

