



## Electric Convection Oven

### Key Features:

- Special air flow grid promotes fluid air movement for a perfect, even bake every time
- Manual temperature control—up to 550° F
- Extremely quick start-up and temperature recovery (start up averages 1° per second to temperature)
- Even bake obtained without rotating product
- Fewer mechanical parts to service and maintain
- Tempered glass window for easy viewing
- Perfect for small-lot production and more frequent bakes for continuous supply of fresh product
- Fan provides consistent temperature with uneven loads

**Urgent**



688 oven shown with optional 8 tray rack

The information contained herein is correct to the best of our knowledge. The recommendations or suggestions are made without guarantee or representation as to results. Freedom from any patent owned by Oliver Packaging and Equipment or other is not to be inferred.

Above specifications subject to change without notice



**Manufactured in the U.S.A.**



Oliver Packaging & Equipment Company  
511 Sixth Street NW • Grand Rapids, MI 49504  
(800) 253-3893 • (616) 356-2950 • www.oliverquality.com



# Electric Convection Oven

## SPECIFICATIONS:

### Electrical:

- 3 Phase, 60 Hz, 460 VAC, 14 AMPS
- 3 Phase, 60 Hz, 230 VAC, 27 AMPS
- 3 Phase, 60 Hz, 208 VAC, 24 AMPS
- 3 Phase, 50 Hz, 375 VAC, 11 AMPS

### Capacity:

- Shelf configuration from 2 to 5
- Rack size: 18" (457mm) x 26 (660mm) pastry baking trays

### Finish:

- Stainless steel construction inside and out

### Dimensions:

- Shipping Weight: 350 lbs. (182kg)
- Net Weight: 300 lbs. (159kg)
- Height: 22 3/4" (578mm)
- Width: 33" (838mm) Depth: 42" (1,067mm)

### Optional Features:

- 4-tray rack with casters
- 8-tray rack with casters

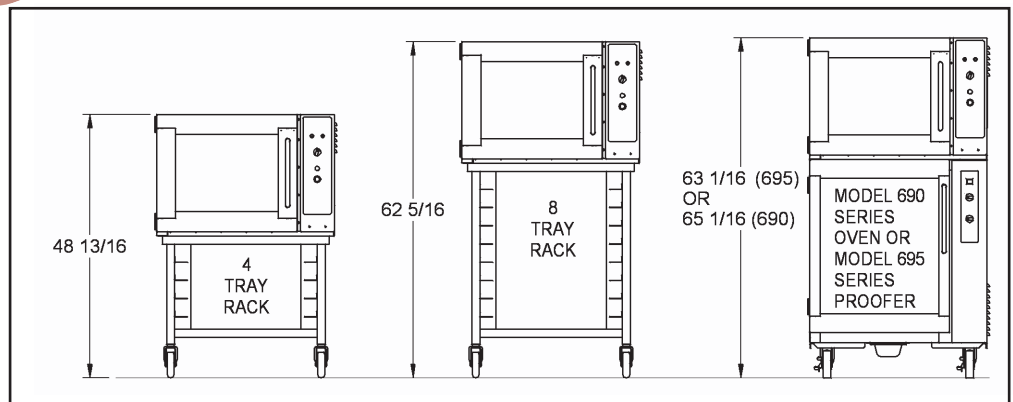
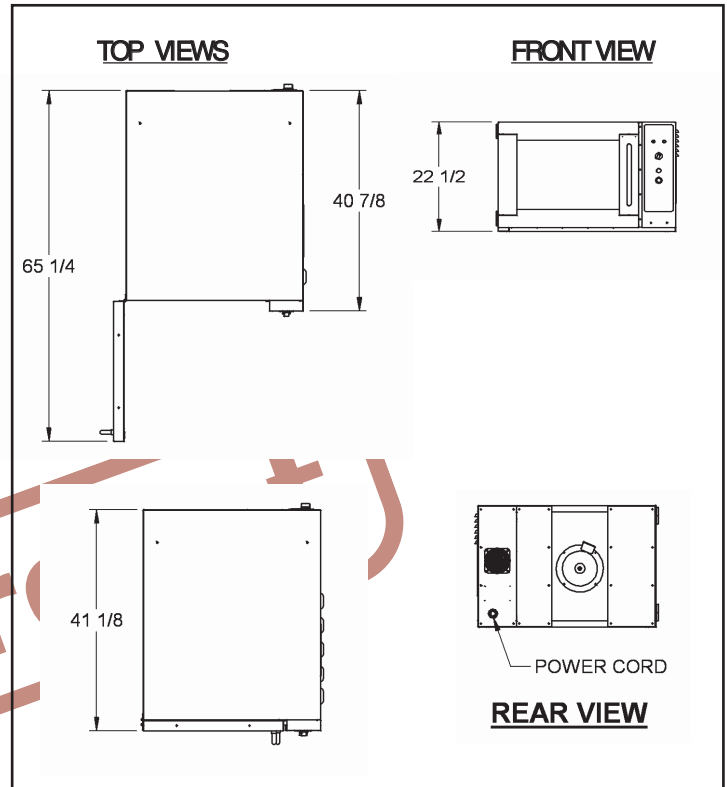

The information contained herein is correct to the best of our knowledge. The recommendations or suggestions are made without guarantee or representation as to results. Freedom from any patent owned by Oliver Packaging and Equipment or other is not to be inferred.

Above specifications subject to change without notice

**Manufactured in the U.S.A.**



Oliver Packaging & Equipment Company  
 511 Sixth Street NW • Grand Rapids, MI 49504  
 (800) 253-3893 • (616) 356-2950 • www.oliverquality.com