



Model 641-21  
Model 641-17  
Model 641-14

## Dough Roller

### Key Features:

- Ideal for pizzas, tortillas, and pie crusts
- Quickly produces crusts of uniform thickness, automatically
- Perfect for applications where floor space is limited
- Easy to operate
- Available in a choice of 14", 17", or 21" widths
- USDA listed



The information contained herein is correct to the best of our knowledge. The recommendations or suggestions are made without guarantee or representation as to results. Freedom from any patent owned by Oliver Packaging and Equipment or other is not to be inferred.

Above specifications subject to change without notice



**Manufactured in the U.S.A.**



Oliver Packaging & Equipment Company  
511 Sixth Street NW • Grand Rapids, MI 49504  
(800) 253-3893 • (616) 356-2950 • [www.oliverquality.com](http://www.oliverquality.com)

**Packaging - Processing**  
**Bid on Equipment**  
**1-847-854-8577**  
[www.bid-on-equipment.com](http://www.bid-on-equipment.com)



Model 641-21  
Model 641-17  
Model 641-14

## Dough Roller

### SPECIFICATIONS:

#### Motor:

1/2 H.P., single phase, 60Hz, 115 VAC, 7.0 AMPS

1/2 H.P., single phase, 60Hz, 230 VAC, 3.5 AMPS

Also available: 1/2 H.P., single phase, 50 Hz, 220 VAC, 4.2 AMPS

#### Lubrication:

Permanently lubricated, sealed ball-bearings

#### Finish:

Stainless steel and corrosion resistant alloys throughout

21" model: 250 lbs. (113kg)

17" model: 240 lbs. (109kg)

14" model: 230 lbs. (104kg)

#### Height:

22" (914mm)

#### Depth:

33" (838mm)

#### Width:

21" model: 37" (914mm)

17" model: 33" (813mm)

14" model: 30" (737mm)

#### Optional:

Powder coated white stand with casters, height: 33" (838mm)

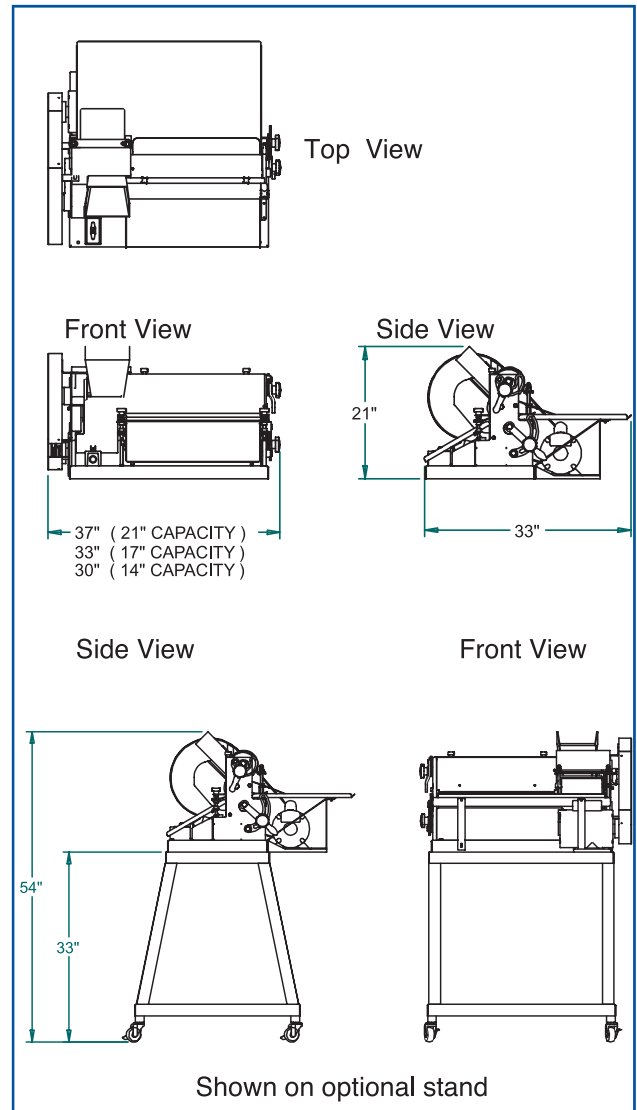

The information contained herein is correct to the best of our knowledge. The recommendations or suggestions are made without guarantee or representation as to results. Freedom from any patent owned by Oliver Packaging and Equipment or other is not to be inferred.

Above specifications subject to change without notice

**Manufactured in the U.S.A.**



Oliver Packaging & Equipment Company  
511 Sixth Street NW • Grand Rapids, MI 49504  
(800) 253-3893 • (616) 356-2950 • www.oliverquality.com

**Packaging - Processing**  
**Bid on Equipment**  
**1-847-854-8577**  
**www.bid-on-equipment.com**