



Grand Rapids, Michigan, U.S.A. 49504-5298

USER'S OPERATING AND INSTRUCTION MANUAL

MODEL 619-16
MODEL 619-20
MODEL 619-24
MODEL 619-24R

DOUGH DIVIDERS

0619S20000-CVR



MODEL 619-16,20,24,&24R DOUGH DIVIDERS
INDEX

SAFETY INSTRUCTIONS.....	0619S20001
DESCRIPTION/SPECIFICATIONS.....	0619S20002
Description/Dimensional Specifications.....	0619S20002-1/3
Electrical Specifications/Wiring Diagrams.....	0619S20002-2/3
OPERATION INSTRUCTIONS.....	0619S20003
MAINTENANCE.....	0619S20004
Cleaning.....	0619S20004-1/6
Lubrication.....	0619S20004-1/6
Hydraulic Oil Specifications.....	0619S20004-1/6
Hydraulic Filter Replacement.....	0619S20004-2/6
Removing The Lid.....	0619S20004-2/6
Replacing The Locking Hook Or Cam.....	0619S20004-2/6
Replacing Plastic Bottom Element.....	0619S20004-3/6
Changing The Blades.....	0619S20004-3/6
Replacing The Thrust Plate.....	0619S20004-4/6
Replacing The Hydraulic Cylinder.....	0619S20004-4/6
Removing The Motor	0619S20004-5/6
Changing The Pump Or Coupling.....	0619S20004-5/6
Replacing The Control Valve	0619S20004-6/6
Cleaning Instructions	0619S20143
TROUBLESHOOTING.....	0619S20005
RECOMMENDED SPARE PARTS LIST.....	0619S20006
PARTS LIST.....	0619S20007
MAIN FRAME ASSEMBLY DRAWING.....	0619S20008
COVERS ASSEMBLY DRAWING.....	0619S20009
HYDRAULIC ASSEMBLY DRAWING.....	0619S20010
LID ASSEMBLY DRAWING.....	0619S20011
PUSHER-16 PART ASSEMBLY DRAWING.....	0619S20043
PUSHER-20 PART ASSEMBLY DRAWING.....	0619S20012
PUSHER-24 PART (SQUARE) ASSEMBLY DRAWING.....	0619S20013
PUSHER-24 PART (ROUND) ASSEMBLY DRAWING	0619S20044
WARRANTY.....	GEN040225
WARRANTY PROCEDURE.....	GEN040226
RETURN PARTS POLICY.....	GEN040227



MODEL 619-16, 20, 24, & 24R DOUGH DIVIDERS

SAFETY INSTRUCTIONS

Every effort has been made by Oliver Products Company to provide you with a safe machine. It is essential, however, that machine operators and maintenance personnel observe the following safety precautions.

1. Before attempting to operate your divider read this manual. Never allow an untrained person to operate this machine.
2. Make sure that the machine is only connected to a properly grounded electrical supply source of sufficient capacity for the load the divider will put on it. Always unplug the machine when it is not in use.
3. Always make sure the machine has been disconnected from the power supply before cleaning or servicing.
4. All guards must be in place before starting the machine.
5. Keep your hands away from the moving parts of the machine.
6. Use only proper replacement parts.
7. Do not wear loose fitting clothing. Shirt tails should be tucked in.
8. In addition to these general safety instructions, also follow the more specific safety instructions given for the different areas of the machine in the operating instructions.



MODEL 619-16, 20, 24, & 24R DOUGH DIVIDERS

DESCRIPTION/SPECIFICATION

Description

The Oliver divider consists of a hopper which can be loaded with dough from a minimum of ten and one half pounds up to forty-five pounds. The lid and sides of the hopper are made of heavy cast aluminum. The moveable hydraulic floor of the hopper is made of a collection of food grade plastic plates which, when moved upward, will compress the dough until it completely fills the remaining area. At this point a group of stainless steel knives come between the plates cutting the dough into equal weight, easy to use pieces.

This machine is ideal for pizza and bakery operations and is mounted on four casters for easy movement about the work area. The divider can divide pieces as small as seven ounces, on a 24 part divider, to as large as forty five ounces, on the 16 part divider. See below for specific maximums.

The hydraulic pump is powered by a two horse power, totally enclosed motor. The system has a built-in four and one half gallon hydraulic oil tank making the machine totally self contained.

Physical specifications

OVERALL MACHINE DIMENSIONS

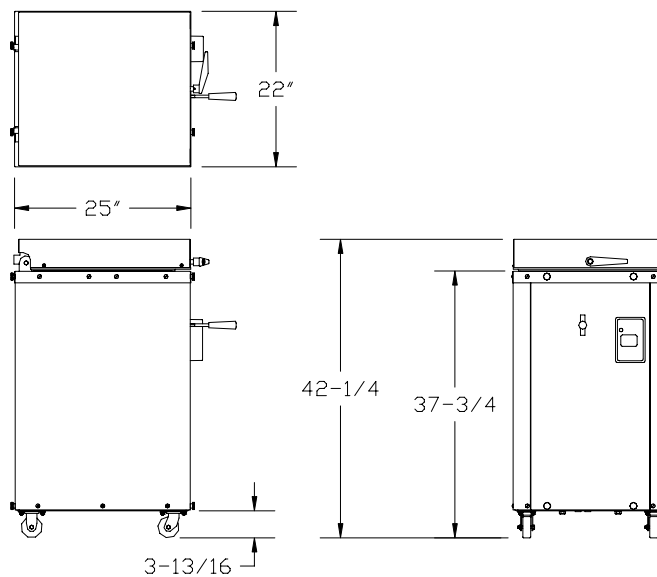

REV. 1-31-96



Physical specifications (continued)

Net Weight:
Approximately 455 pounds.

Shipping Weight:
Approximately 500 pounds.

Product Capacities:
Fill Capacity (approximate) = 10-1/2 to 45 pounds

Divided piece Size (approximate):
16 part dividers = 10-1/2 to 45 ounces
20 part dividers = 8-1/2 to 36 ounces
24 part dividers = 7 to 30 ounces

Electrical Specifications

2 Horse Power, 1 phase, 60 hertz, 230 Volts AC, 10 Amps.
2 Horse Power, 3 phase, 60 hertz, 208 Volts AC, 6.5 Amps.
2 Horse Power, 3 phase, 60 hertz, 230 Volts AC, 6.2 Amps.
2 Horse Power, 3 phase, 60 hertz, 460 Volts AC, 3.1 Amps.
Others consult factory

Electrical Wiring Diagrams

1 ph, 60 hz, 230 VAC

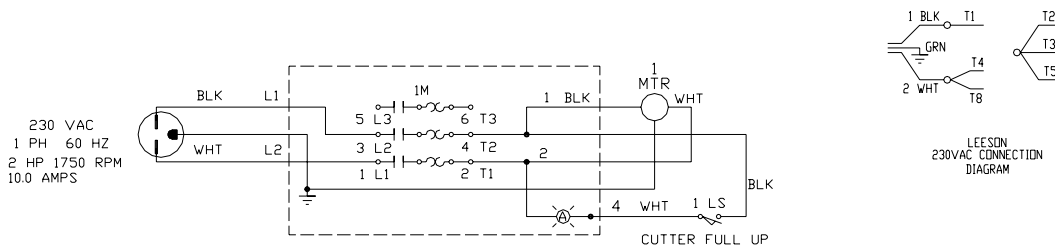

Rev. 1-31-96



Electrical Wiring Diagrams (Continued)

3 ph, 60 hz, 208/230 VAC

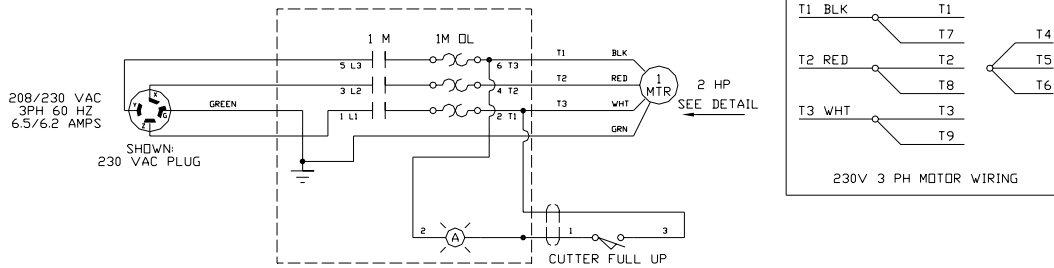

3 ph, 60 hz, 460 VAC

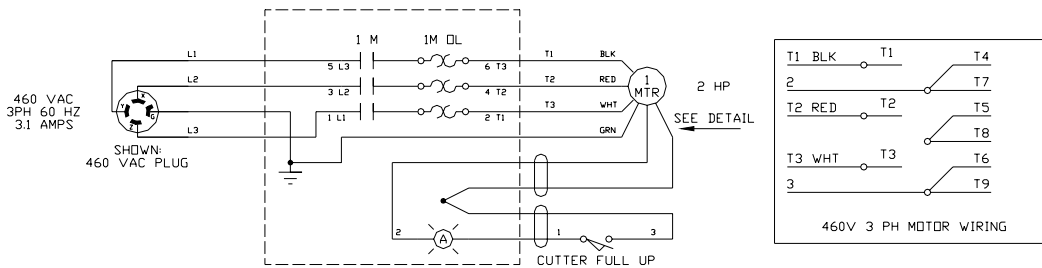

Rev. 5-24-96



MODEL 619-16, 20, 24, & 24R DOUGH DIVIDERS

OPERATING INSTRUCTIONS

Before You Start

CAUTION

THE DIVIDER SHOULD **ONLY** BE PLUGGED INTO AN OUTLET WITH THE SAME VOLTAGE AS STATED ON THE NAMEPLATE

Before starting a new divider with **THREE PHASE** electrical power for the first time you should check to see if the motor is running in the correct direction. Remove the front cover by removing the four thumbscrews which secure it; you will also have to remove the handle from the directional control lever before removing the front cover. Once the cover has been removed you should be able to see the fan end of the motor on your divider, this fan **MUST** rotate in a clockwise direction.

CAUTION

EXTENDED RUNNING OF A DIVIDER WITH THE MOTOR ROTATING IN THE INCORRECT DIRECTION WILL SEVERELY DAMAGE THE HYDRAULIC PUMP OF YOUR DIVIDER.

If the motor is rotating in the incorrect direction turn the machine off, disconnect it from the power supply and have a qualified electrician reverse two of the three power wires in the plug at the end of the power cord. **DO NOT** move the ground, (green), wire.

WARNING

ALWAYS HAVE ELECTRICAL WORK DONE BY QUALIFIED ELECTRICIANS ONLY.

Recheck the divider making sure that it is now running in the correct direction, (clockwise looking at the fan end of the motor).

Basic Operation

- Start by weighing out a piece of dough, which, when divided by the number of compartments available on your divider, will provide you with the desired end weight. For example: a thirty pound piece of dough after division on a twenty-four part divider will yield twenty-four twenty ounce pieces, perfect for molding into one and a quarter pound loaves of bread.
- Make sure the floor of the hopper has been lowered before attempting to open the lid of the divider.

Rev. 5-5-00



Basic Operation (Continued)

- Open the lid and load the preweighed dough into the hopper. Spread the dough over the floor of the hopper making it approximately the same height, this is done to eliminate large air pockets and to insure equal division of the dough.
- Close the lid and turn the handle in a clockwise direction making sure it is secure.
- With the machine running grasp the control valve handle and lift it to start the floor of the hopper up. Hold it in this position until the light on the starter switch box comes on, this means that the upward stroke has stopped and that division is complete. Let loose of the valve handle when you see the light come on.
- Press the control valve handle down slightly to release the pressure on the lid so it can be opened. Open the lid.
- We suggest that the cut pieces of dough be removed as soon as possible to prevent them from sticking together.
- The above process may now be repeated.

WARNING

NEVER LEAVE DOUGH IN THE MACHINE; RISING DOUGH MAY CAUSE EXPLOSIVE PRESSURES TO DEVELOP.

WARNING

NEVER FORCE THE LID HANDLE OPEN

- If dough has been left in the machine and the lid handle is difficult to turn, recompress the dough by lifting the control valve handle until the light come on. This will raise the floor of the hopper, after doing so lower the hopper floor by pressing down on the control valve handle. This may have to be done more than once if dough has been left in the machine for quite awhile. With the hopper floor all the way down try to open the lid again, the handle should turn easily, if it does not, recompress the dough and try again.
- The divider is designed so that if dough is left in the hopper it will eventually force the hopper's floor to the bottom, thus allowing the dough to vent to the outside of the machine through openings on the left side. If dough is coming out of these openings follow the steps above recompressing the dough a number of times before attempting to open the lid.

Rev. 5-5-00



**MODEL 619-16, 20, 24, & 24R DOUGH DIVIDERS
MAINTENANCE**

WARNING

**ALWAYS MAKE SURE THE MACHINE HAS BEEN DISCONNECTED
FROM THE POWER SUPPLY BEFORE CLEANING OR SERVICING.**

Cleaning

Remove- all scraps from lower pan. Open side doors and brushing out all scraps. **Wash** all interior surfaces; Knives, pusher plates, hopper, lid surface with a damp rag and mild soap solution. The exterior and contact surfaces should be cleaned daily using common cleaners. The **knives** should be extended for easier cleaning. This can be done by placing the cleaning separator, furnished with the machine, **IN THE CENTER OF THE HOPPER** straddling the knives. Close the lid and bring the floor of the hopper up until the light on the manual starter is on, lower the floor slightly. **Open the lid and disconnect the divider from the power supply.** Clean the knives and plastic compartment floors of all dough build-up. **Rinse** all interior surfaces with a damp rag and clean water. **Sanitize** all interior surfaces with a damp rag and sanitizing solution. **Air Dry**, leave divider lid open and allow interior to air dry before using.

CAUTION

**IF NOT CLEANED A BUILD-UP OF DRIED DOUGH BETWEEN THE
PLASTIC FLOORS AND THE KNIVES COULD DAMAGE THE DIVIDER.**

In addition to the general cleaning discussed above, it is important that you check for and remove scraps of dried dough from between the blade holder and the bottom thrust plate. This can be done by first extending the knives as described above and then by removing the front cover from the machine by removing the four knobs and the control valve handle. This will allow access to the blade holder area which can then be cleaned of all dried scraps of dough. When finished replace the front cover.

Occasionally, as required, you should also remove the build up of flour and dough particles in the base of the machine around the motor.

Lubrication

The machine requires no lubrication but the oil level in the hydraulic system should be checked periodically. To check the oil level remove the rear cover by removing the four knobs which secure it to the divider, then remove the tank breather/cap and determine where the top of the oil is in relation to the top surface of the tank. Fill with oil to within approximately one inch of the top surface. If necessary add **HYDRAULIC OIL** to return it to the proper level, **DO NOT OVERFILL**. In addition to the above we advise replacing the hydraulic oil in the system approximately every three years.



Hydraulic Oil Specification

The hydraulic oil used in your divider should be made of good quality base stocks compounded with the following additives: anti-wear, anti-oxidation, antifoaming, and antirust. In addition it should be an "ISO" viscosity grade No. 32. Rev. 7-30-02

Hydraulic Filter Replacement

At least once a year the throw-away filter on the hydraulic system should be replaced, more often when under heavy use. To replace the filter remove the front cover unscrew the old filter and replace it with a new one. The filter is located on the return line near the tank.

Removing The Lid

- Remove the lid cover by removing the four screws which secure it in position.
- Open the lid as far as it will go.
- Release the tension on the two large torsion springs by moving the long leg of the spring to the side and out from behind the bracket.

WARNING

USE CARE AS THE LID WILL DROP ONCE THE SPRING TENSION HAS BEEN REMOVED.

- Close the lid and remove the right hand snap ring from the lid hinge pin and push the pin to the left to remove it.
- Reassemble by reversing the above steps.

Replacing The Locking Hook Or Cam:

- Remove the lid cover by removing the four screws which secure it in position.
- Detach the spring from the hook.
- Open the lid.
- Turn the handle until the pin securing the cam to the shaft is in line with the notch in the locking hook. Using a small drift punch force the pin upwards removing it from the handle shaft.
- Pull the shaft and cam assembly forward out of the lid.
- The hook or locking cam can now be replaced.
- Reassemble by reversing the above steps.



Replacing A Plastic Bottom Element

- Open the lid and raise the bottom of the hopper.
- Turn the machine off and disconnect it from the power supply.
- Remove the front and rear panels to gain access to the pusher components.
- Remove the nut securing the float to the thrust plate.
- Using a block of wood or other soft material to protect the threads on the float, force the float and bottom element assembly upwards until it is free from the thrust plate and then lift the assembly from the blades.
- Once the assembly has been removed, the bottom element can be disassembled from the float by removing the fasteners from the under side of the element which secure it to the float.
- Replace each float and element assembly by reversing the above steps.

Changing The Blades

- To ease removal of the blade assembly the front, rear, and side panels should first be removed from the machine.
- Next remove all of the float and element assemblies, see replacing plastic bottom elements covered above.
- Remove the nuts securing the four blade holder braces, to the star plate.
- Lift the entire blade assembly, (blades, blade holder, and braces), out of the hopper.
- Once removed, a blade or blades can be replaced. Remember it is important before securing any blades that the blade holder and knife assembly be inverted on a surface plate or other known flat surface, verifying that all the blades are level and in line with each other. If no other flat surface is available the lid of the divider could be removed and used for this purpose.
- Once complete, re-insert the assembly in the hopper and reverse the above steps to re-assemble the machine.



Replacing The Thrust Plate

- Should the thrust plate require replacement you should start by removing the blade assembly as described above.
- Remove the bolt securing the thrust plate to the cylinder rod. Once this bolt is removed the thrust plate can be lifted from the machine and replaced.
- When the machine is re-assembled the bolt securing the thrust plate to the cylinder rod should be installed using "Loctite" adhesive to prevent loosening during operation. The remaining components can be reinstalled by reversing the above steps.

Replacing The Hydraulic Cylinder

- Using the four wedges extend the knives about half of their travel. Turn the machine off and disconnect it from the power supply.
- To remove the hydraulic cylinder the front, rear, and side panels must be removed from the machine.
- Place blocks of wood between the thrust plate and the cylinder mounting channel to secure it during cylinder removal.
- Remove one of the center float assemblies, (see above procedures). Once this has been done the bolt securing the thrust plate to the cylinder rod can be removed using a universal socket style wrench.
- Remove the four screws securing the star to the outer cylinder rod.
- Remove the bolts securing both the main starter switch bracket and the limit switch bracket to the hex support rods. **DO NOT** disconnect the wires.
- Remove one of the snaprings securing the yoke and safety lock pivot pin. Remove the pin so that the linkage can be unhooked from the top of the machine.
- Remove the eight screws securing the cylinder to the cylinder mounting channel.
- Remove the four bolts securing the cylinder mounting channel to the lower hex support rods.
- The upper portion of the divider can now be removed and set to one side.



Replacing The Hydraulic Cylinder (Continued)

- Disconnect both high pressure hoses at the cylinder allowing removal of the cylinder for repair or replacement.
- When the machine is reassembled the bolt securing the thrust plate to the cylinder rod should be installed using “Loctite” thread locker #242 to prevent loosening during operation. All other components can be reinstalled by reversing the above steps.

Removing The Motor

- Remove the front, rear and “Motor Side” panels.
- Remove the four screws securing the pump bracket to the front of the motor.
- Remove the four nuts securing the motor to the base of divider.
- Remove the terminal cover on the motor and disconnect the wiring, remember to note the wire locations to ease replacement of the motor.
- The motor should now be free and can be removed by sliding the motor out and lifting it free of the machine.
- Re-assemble by reversing the above steps.

Changing The Pump Or Coupling

- Remove the rear cover and the “Motor Side” panels.
- Loosen the intake hose at the pump, make sure you have something available to catch the hydraulic oil leaking from the end of the hose when it is disconnected.
- Remove the high pressure hose from the outlet side of the pump.
- Remove the four bolts from the feet of the motor which secure it to the base this will allow the motor to be pivoted slightly to allow pump removal.
- Remove the bolts securing the pump to the bracket, pivot the motor and slide the pump with its half of the coupling out and free of the motor.
- Replace the pump by reversing the above procedures.



Replacing The Control Valve

- Remove the front and side panels from the divider.
- Disconnect the three high pressure hoses and remove the filter head assembly from the machine.
- Remove the lower pivot bolt from the lower end of the linkage connecting the valve and the control handle.
- Remove the four screws holding the valve to the valve mounting plate and remove the valve from the divider.
- Remove the remaining linkage parts from the old valve and re-install them on the new valve. The new valve can then be installed in the divider by reversing the above procedures.
- Once the installation has been completed it **IS NOT** necessary to adjust the pressure relief valve to allow proper operation of the divider. Note: Oliver's valves are normally preset at the factory and adjustment **IS NOT** necessary. Should it become necessary to change the pressure relief setting follow the two steps given below.
- Connect a pressure gauge at the quick disconnect provided on the high pressure hose at the pump fitting. Note: a pressure gauge test kit can be purchased from Oliver Products Co. at additional cost.
- With the pump running use the calibrating screw in the bottom of the valve to set the pressure at 1100 PSIG secure the calibrating screw in place with the locking nut once the proper pressure has been achieved.

CLEANING INSTRUCTIONS FOR THE 619



RUN PRESS ALL THE WAY UP

*****W A R N I N G*****

UNPLUG MACHINE



**USING THE ACCESS DOORS ON BOTH SIDES OF THE UNIT
PULL DOOR UP, USE ONE HAND TO HOLD DOOR UP
WIPE DOWN MACHINE WITH OTHER, USING A RAG OR A BRUSH**



MODEL 619-16, 20, 24, & 24R DOUGH DIVIDERS

TROUBLE SHOOTING GUIDE

The “End of Stroke Light” does not come on.

Possible Causes

- There may be a disconnected wire.
- The bulb may have burnt out.
- The limit switch is not adjusted properly.
- The limit switch is not operating and needs replacement.

The motor “Hums” but will not start.

Possible Causes

- The motor is a dual voltage motor and may be wired for high voltage, but, an attempt is being made to run it on low voltage.
- The electric supply to the motor is single phase instead of three phase.
- One of the leads of the three phase system has opened.

The motor runs but “Stalls” at either end of the cylinder’s travel.

Possible Causes

- The incorrect overload relay was installed or the setting of that overload relay is incorrect.
- The setting of the hydraulic relief valve is too high.

The motor runs “Slowly” but stalls easily before completion of its stroke.

Possible Causes

- The motor is wired for high voltage but is connected to a low voltage supply.

The motor has “Stalled” and can not be restarted.



Possible Causes

- The overload relay has tripped. Allow the relay about five minutes to cool and attempt to restart the divider.

The divider is not cutting properly.

Possible Causes

- Dough scraps and flour have accumulated between the blade holder and the float plate. See "Cleaning" under maintenance.
- Check the oil level in the tank, refill if necessary see "Lubrication" under maintenance.
- Check to see if the calibrating screw on the control valve has become loose. If it has check the procedure for setting the pressure, given under "Replacing the Control Valve" in the maintenance section.



MODEL 619-16, 20, 24, & 24R DOUGH DIVIDERS

RECOMMENDED SPARE PARTS

<u>PART NUMBER</u>	<u>PART DESCRIPTION</u>	<u>NO. REQ'D.</u>
7024-6101	Extension Spring	1
4605-1000-0028	LH Lid Spring	1
4605-1000-0029	RH Lid Spring	1
5835-7636	Coiled Pin	1
5114-9556	Hydraulic Filter	1
0620-0047	Blade Holder Brace	4
0620-0012-1	Star Plate	1
5757-8081	Limit Switch	1
5709-9924	Starter Enclosure	1
5709-0191	Pilot Light	1
5709-3040	Motor Starter (3-60-460V)	1
5709-3041	Motor Starter (3-60-230V)	1
5709-3042	Motor Starter (3-60-208V)	1
5709-3043	Motor Starter (1-60-230V)	1

SPARE PARTS FOR MODEL 619-16 ONLY

0620-0011-002	Blade Holder	1
0620-0048-002	Plastic Outside Plate	12
0620-0049-002	Plastic Inside Plate	4
0620-0052-003	Large Lower Blade	1
0620-0053-003	Large Upper Blade	1
0620-0054-003	Small Blade	12
0620-0055-003	Outside Blade	8

SPARE PARTS FOR MODEL 619-20 ONLY

0620-0011	Blade Holder	1
0620-0048-003	Plastic Outside Plate	16
0620-0049-003	Plastic Inside Plate	4
0620-0052-001	Large Lower Blade	1
0620-0053-001	Large Upper Blade	1
0620-0054-001	Small Blade	16
0620-0055-001	Outside Blade	12

SPARE PARTS FOR MODEL 619-24 ONLY

0620-0064	Blade Holder	1
0620-0062-001	Plastic Plate	24
0620-0066-001	Lower Blade	3
0620-0065-001	Upper Blade	5

Rev. 8/22/05



RECOMMENDED SPARE PARTS (Continued)

<u>PART NUMBER</u>	<u>PART DESCRIPTION</u>	<u>NO. REQ'D.</u>
<u>SPARE PARTS FOR MODEL 619-24R ONLY</u>		
0620-0011-001	Blade Holder	1
0620-0048-001	Plastic Outside Plate	20
0620-0049-001	Plastic Inside Plate	4
0620-0052-002	Large Lower Blade	1
0620-0053-002	Large Upper Blade	1
0620-0054-002	Small Blade	20
0620-0055-002	Outside Blade	16

OPTIONAL SPARE PARTS

0620-0036	Handle Shaft	1
0620-0037-1	Latch Cam	1
0619-0018-001	Handle Rod	1
0619-0019	Handle Hub	1
5911-7001	Handle Knob	1
5148-5623	Valve (Hydraulic)	1
5137-7004	Hydraulic Pump	1
5604-6958	Coupling	1
6303-6613	Motor 3 ph, 60 hz, 208/230/460 VAC	1
6303-6725	Motor 1 ph, 60 hz, 230VAC	1
0620-0050	Outer Plunger (619-16, 619-20, 619-24)	4
0620-0050-001	Outer Plunger (619-24R)	4
0620-0051	Inner Plunger (619-16, 619-20)	2
0620-0051-001	Inner Plunger (619-24R)	2



**MODEL 619-16, 20, 24, & 24R DOUGH DIVIDERS
PARTS LIST**

<u>ITEM NO.</u>	<u>PART DESCRIPTION</u>	<u>PART NO.</u>
001	Brace-Lower W/Holes	0620-0005-001
002	Brace-Lower	0620-0006
003	Plate-Cylinder Support	0620-0007-001
004	Base	0620-0008
005	Plate-Star	0620-0012-1
006	Panel-Separation	0620-0032
008	Actuator-Limit Switch	0620-0044-1
009	Spacer-Cylinder Rod	0620-0045
010	Caster-Ridged	5902-2378
011	Caster-Swivel W/Brake	5902-2377
101	Guard-Top Cover (Painted)	0620-0001
101	Guard-Top Cover (Stainless)	0620-0001-001
102	Cover-Side (Painted)	0620-0029
102	Cover-Side (Stainless)	0620-0029-002
103	Cover-Front (Painted)	0620-0030
103	Cover-Front (Stainless)	0620-0030-003
104	Cover-Rear (Painted)	0620-0031
104	Cover-Rear (Stainless)	0620-0031-001
105	Screw-Thumb	5843-0536
106	Cover-Side W/Chute (Painted)	0620-0029-004
106	Cover-Side W/Chute (Stainless)	0620-0029-005
107	Chute-Round Hopper Dough (Painted)	0619-0027
107	Chute-Round Hopper Dough (Stainless)	0619-0027-003
107	Chute-Square Hopper Dough (Painted)	0619-0027-006
107	Chute-Square Hopper Dough (Stainless)	0619-0027-008
108	Handle-Pull	5908-5101
109	Plate-Handle Backing	0619-0028
201	Stirrup	0620-0015
202	Safety Lock	0620-0016
203	Rod-Valve Actuating	0620-0019-002
204	Clevis-Rod	0620-0020
205	Rod-Eye	0620-0021
206	Pin-Long	0620-0022
208	Rod-Handle	0620-0024-002
209	Pin-Stirrup Pivot	0620-0025
210	Lever-Valve Actuating	0620-0026-001
211	Plate-Valve Mtg.	0620-0027-001
212	Tank-Oil	0620-0069-002
213	Spacer	0620-0086
214	Hose Clamp	5106-8087
215	Filter Head	5114-9554
216	Filter-Spin On	5114-9556
217	Cylinder-Custom Hydraulic	5108-7818



PARTS LIST (Continued)

<u>ITEM NO.</u>	<u>PART DESCRIPTION</u>	<u>PART NO.</u>
218	Flange-Tank	5115-0388
219	Fitting-Elbow	5115-2090
220	Fitting-Hose	5115-2079
221	Fitting-Adapter	5115-4031
222	Fitting-Adapter	5115-4032
223	Hose-Bottom Cylinder	5121-8169
224	Flange-Pump Mounting	5137-7375
225	Hose-Pump	5121-8173
226	Hose-Upper	5121-8174
227	Hose-Hydraulic	0619-0016
228	Pump-Vane	5137-7004
229	Tube-Return	5147-0130
230	Valve	5148-5623
231	Breather-Tank	5149-0204
232	Coupling	5604-6958
233	Knob	5911-7001
234	Plate-Cylinder Alignment	0620-0120
235	Nipple-Black Pipe	6203-0407
236	Coupling-Black Pipe	5115-0332
238	Valve-Check	5148-5217
239	Spacer-Pump/Flange	0619-0044
301	Hook-Locking	0620-0017-3
302	Pin-Hinge	0620-0033
303	Clamp-Spring	0620-0034
304	Bracket-Spring	0620-0035
305	Shaft-Handle	0620-0036
306	Cam-Latch	0620-0037-1
307	Rod-Handle	0619-0018
308	Spring-LH	7030-0024
309	Spring-RH	7030-0023
310	Spring-Extension	7024-6101
311	Lid-Round (619-16, -20, -24R)	0619-0022
311	Lid-Square (619-24 Only)	0620-0018-001
313	Hub-Handle	0619-0019
314	Knob-Handle	5911-7001
401	Adj. Upper Brace W/Holes	0619-0023
402	Adj. Upper Milled Brace	0619-0024
403	Adj. Rear Upper Brace	0619-0025
404	Plate-Thrust (619-16)	0620-0009-003
404	Plate-Thrust (619-20)	0620-0009
404	Plate-Thrust (619-24R)	0620-0009-002
405	Separator-Cleaning	5503-4301
406	Blade Holder (619-16)	0620-0011-002
406	Blade Holder (619-20)	0620-0011
406	Blade Holder (619-24R)	0620-0011-001



PARTS LIST (Continued)

<u>ITEM NO.</u>	<u>PART DESCRIPTION</u>	<u>PART NO.</u>
407	Top Cover	0620-0013
408	Round Hopper	0619-0021-001
409	Brace-Blade Holder	0620-0047
410	Plate-Plastic Outer (619-16)	0620-0048-002
410	Plate-Plastic Outer (619-20)	0620-0048-003
410	Plate-Plastic Outer (619-24R)	0620-0048-001
411	Plate-Plastic Inner (619-16)	0620-0049-002
411	Plate-Plastic Inner (619-20)	0620-0049-003
411	Plate-Plastic Inner (619-24R)	0620-0049-001
412	Plunger-Outer Lifting (619-16 & -20)	0620-0050
412	Plunger-Outer Lifting (619-24R)	0620-0050-001
413	Plunger-Inner Lifting (619-16 & -20)	0620-0051
413	Plunger-Inner Lifting (619-24R)	0620-0051-001
414	Blade-Large Lower (619-16)	0620-0052-003
414	Blade-Large Lower (619-20)	0620-0052-001
414	Blade-Large Lower (619-24R)	0620-0052-002
415	Blade-Large Upper (619-16)	0620-0053-003
415	Blade-Large Upper (619-20)	0620-0053-001
415	Blade-Large Upper (619-24R)	0620-0053-002
416	Blade-Small Circular (619-16)	0620-0054-003
416	Blade-Small Circular (619-20)	0620-0054-001
416	Blade-Small Circular (619-24R)	0620-0054-002
417	Blade-Outside (619-16)	0620-0055-003
417	Blade-Outside (619-20)	0620-0055-001
417	Blade-Outside (619-24R)	0620-0055-002
418	Pin-Guide	0620-0056
419	Catch	0620-0067-1
420	Bracket-Top Cover Mounting	0620-0120
421	Adjustable Hex	0619-0026
422	Kit-Latch Shim	0619-0029K
501	Upper Brace W/Holes Adjustable	0620-0002-004
502	Upper Milled Brace Adjustable	0620-0003-002
503	Plate-Thrust (619-24)	0620-0009-001
504	Separator-Cleaning	5503-4301
505	Blade-Holder	0620-0047
506	Plunger-Outer Lifting	0620-0050
507	Plate-Hopper Front	0620-0059
508	Plate-Hopper Rear	0620-0060
509	Plate-Hopper Side	0620-0061
510	Plate-Square Plastic	0620-0062-001
511	Rear Upper Brace Adjustable	0620-0063-003
512	Holder-Square Blade	0620-0064
513	Blade-Upper (619-24)	0620-0065-001



PARTS LIST (Continued)

<u>ITEM NO.</u>	<u>PART DESCRIPTION</u>	<u>PART NO.</u>
514	Blade-Lower (619-24)	0620-0066-001
515	Catch	0620-0067
516	Hex-Adjustable	0619-0026
517	Plate-Hopper Side W/Chute	0620-0061-001
601	Bracket-Limit Switch	0620-0041-001
602	Bracket-Starter	0620-0042-1
603	Enclosure-Manual Starter	5709-9924
604	Pilot Light	5709-0191
605	Motor Starter (3-60-460V)	5709-3040
605	Motor Starter (3-60-230V)	5709-3041
605	Motor Starter (3-60-208V)	5709-3042
605	Motor Starter (1-60-230V)	5709-3043
606	Switch-Limit	5757-8081
607	Shockmount	5918-6636
608	Motor 3 ph, 60 hz, 208/230/460 VAC	6303-6613
608	Motor 1 ph, 60 hz, 230 VAC	6303-6725



MODEL 619-16, 20, 24, & 24R DOUGH DIVIDERS MAIN FRAME ASSEMBLY

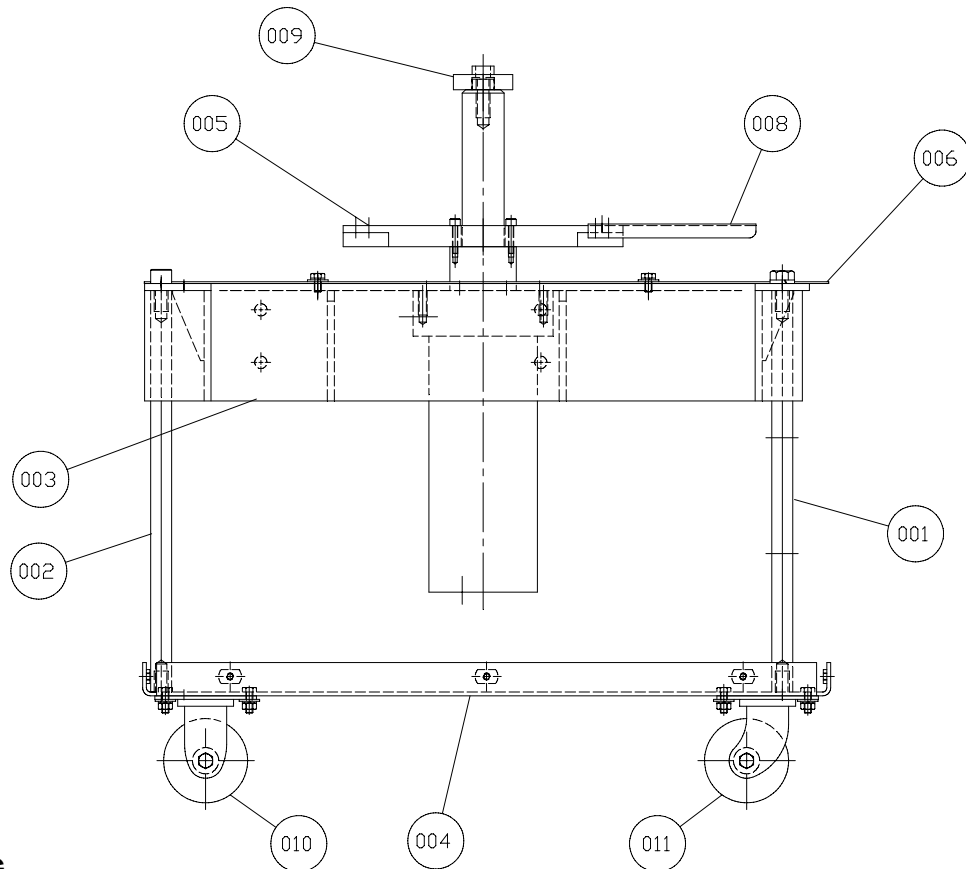
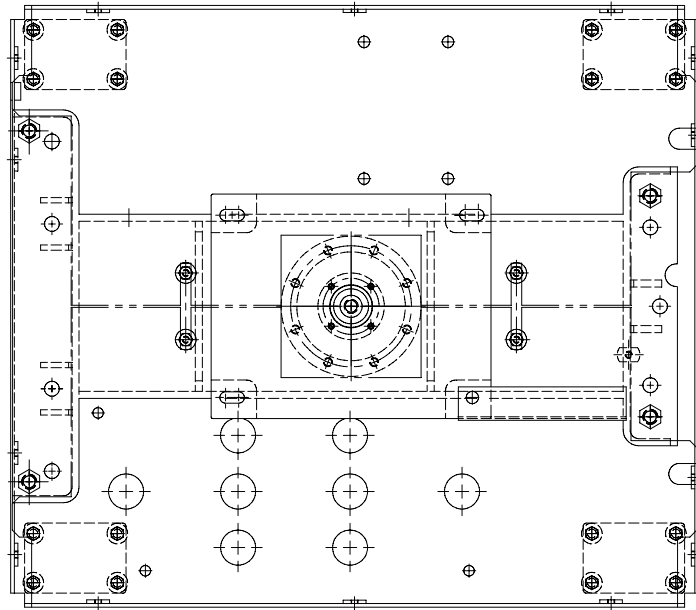

DRAWING



COVERS ASSEMBLY DRAWING FRAME ASSEMBLY

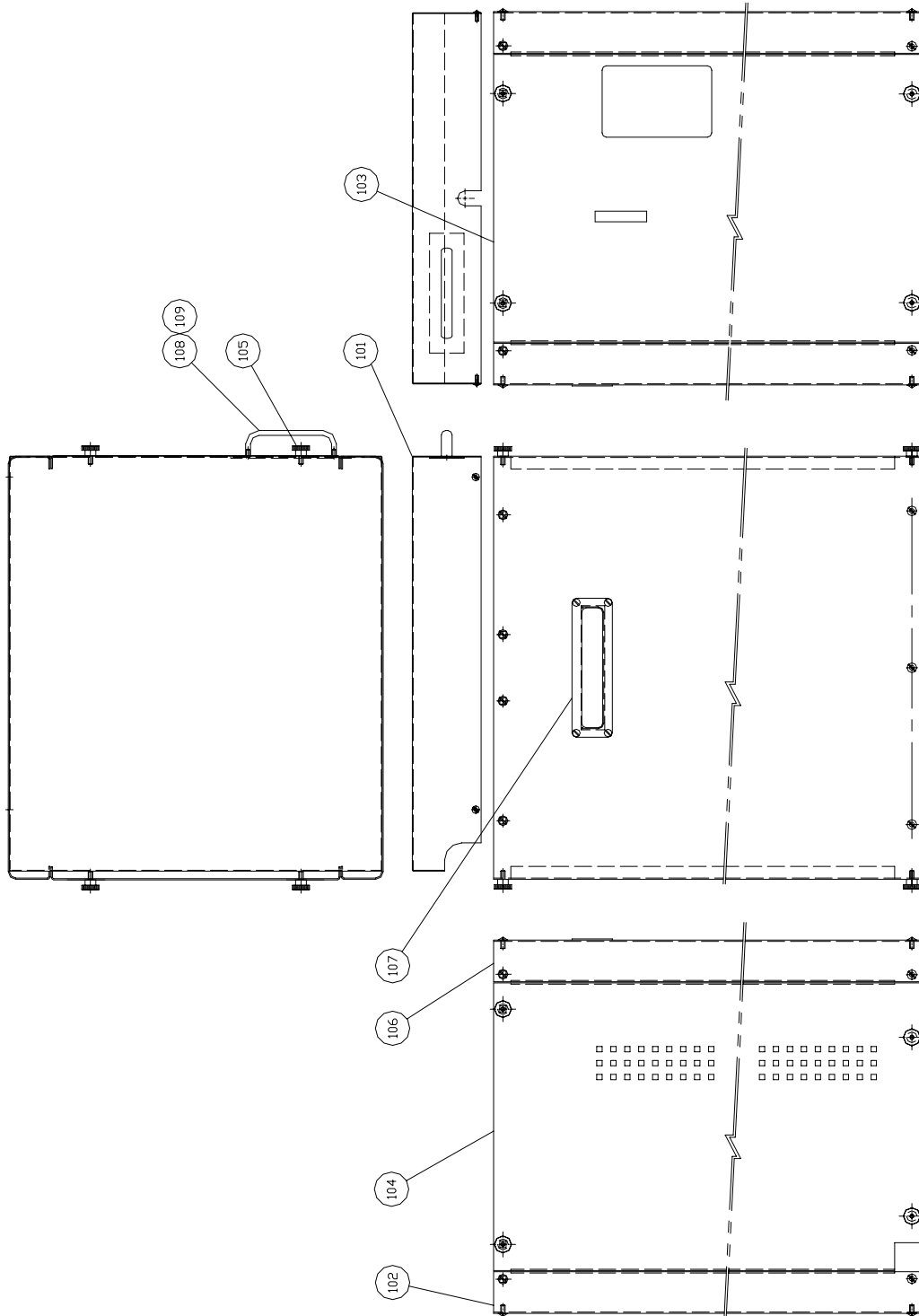



**MODEL 619-16, 20, 24, & 24R DOUGH DIVIDERS
HYDRAULIC ASSEMBLY DRAWING**

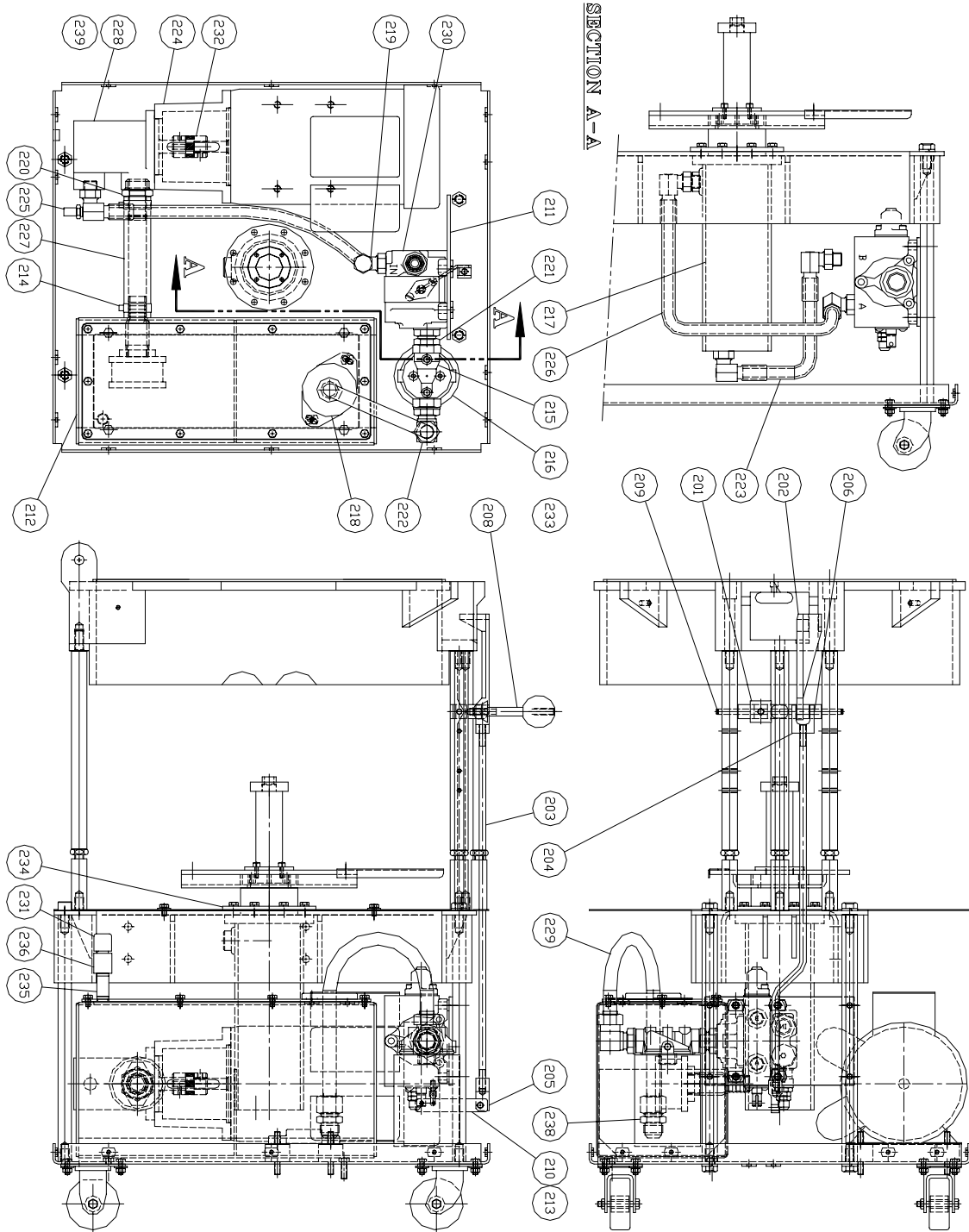

Rev. 12/21/04



MODEL 619-16, 20, 24, & 24R DOUGH DIVIDERS

LID ASSEMBLY DRAWING

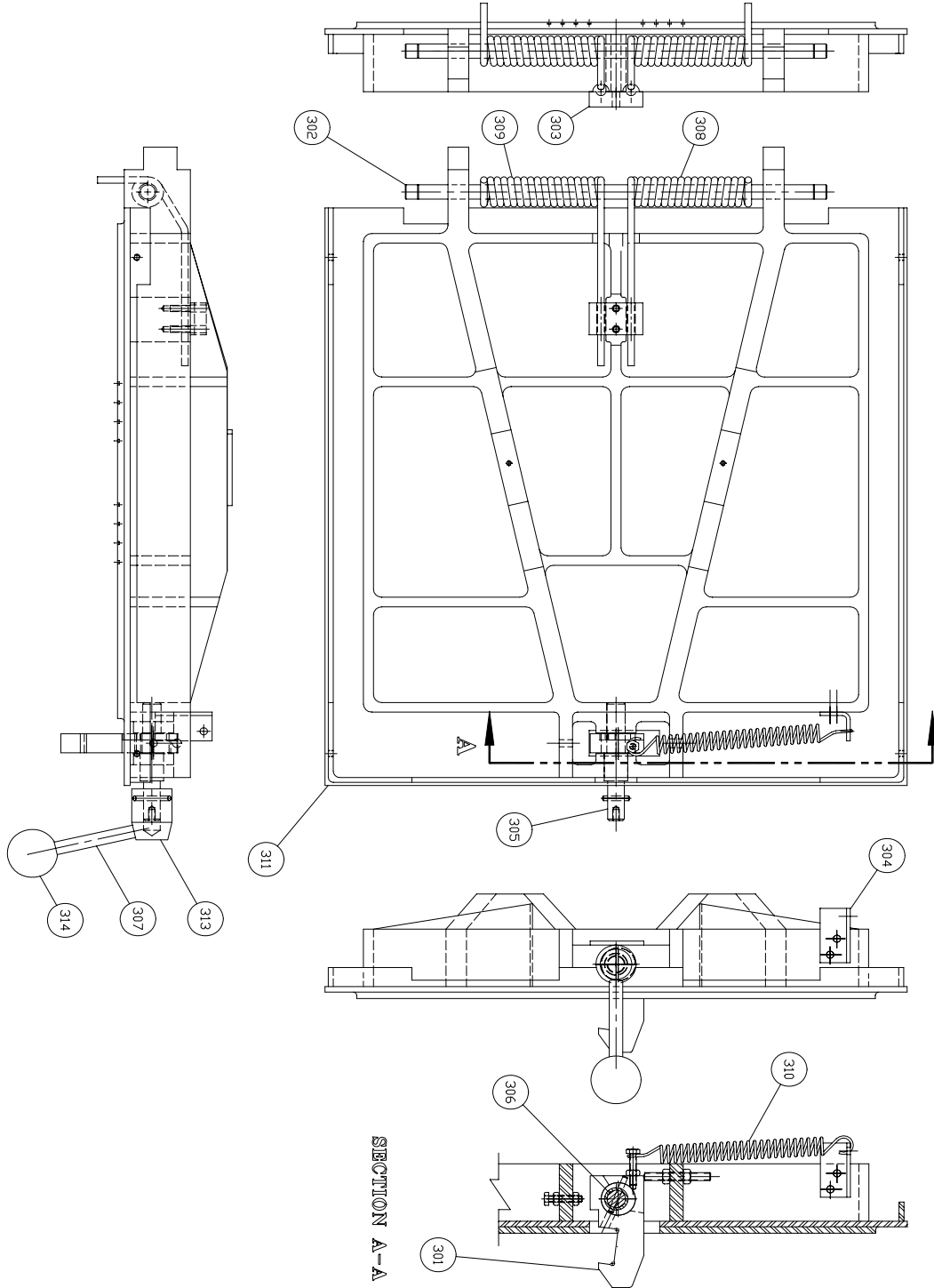



MODEL 619-16, 20, 24, & 24R DOUGH DIVIDERS

16 PART PUSHER ASSEMBLY DRAWING

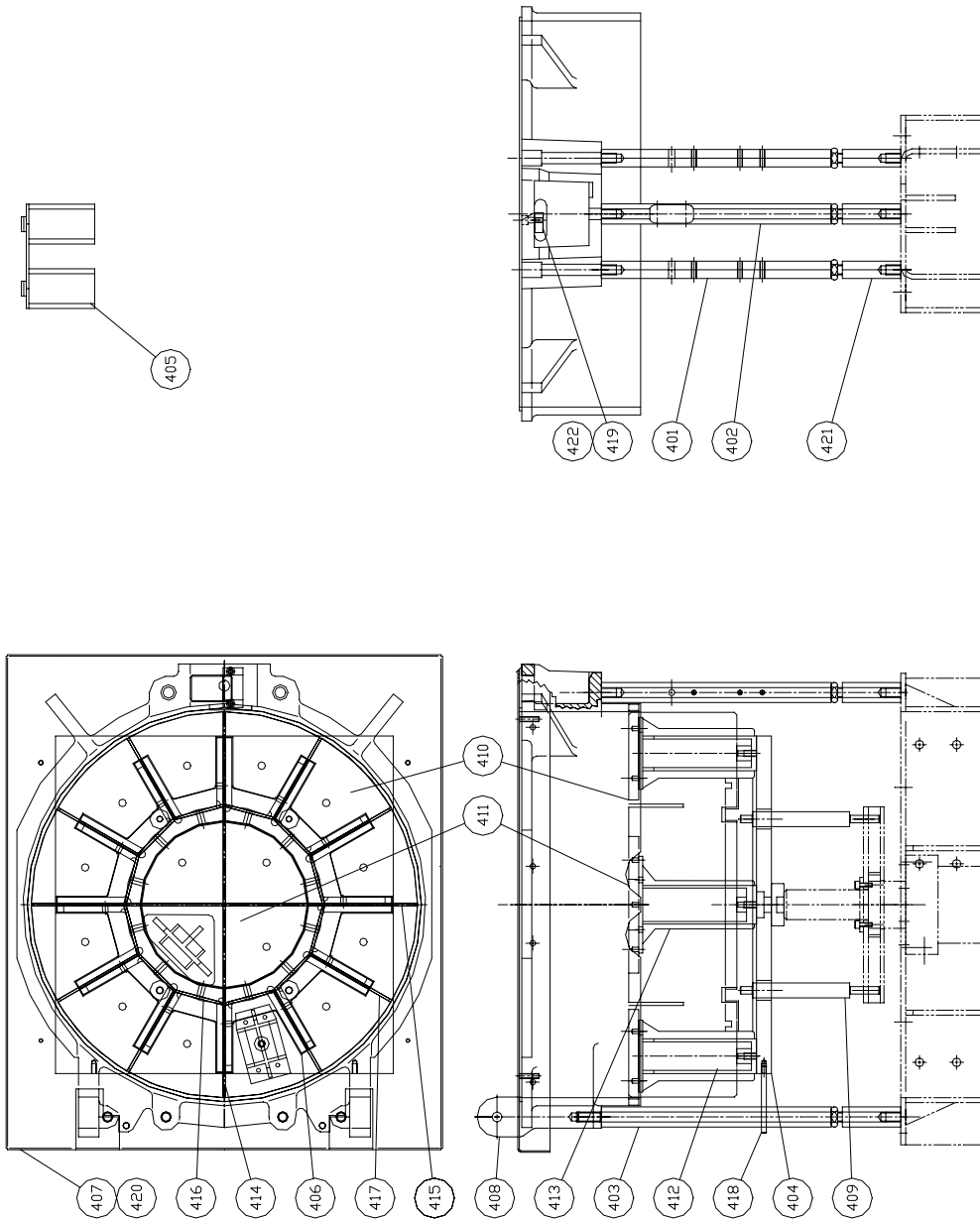



MODEL 619-16, 20, 24, & 24R DOUGH DIVIDERS

20 PART PUSHER ASSEMBLY DRAWING

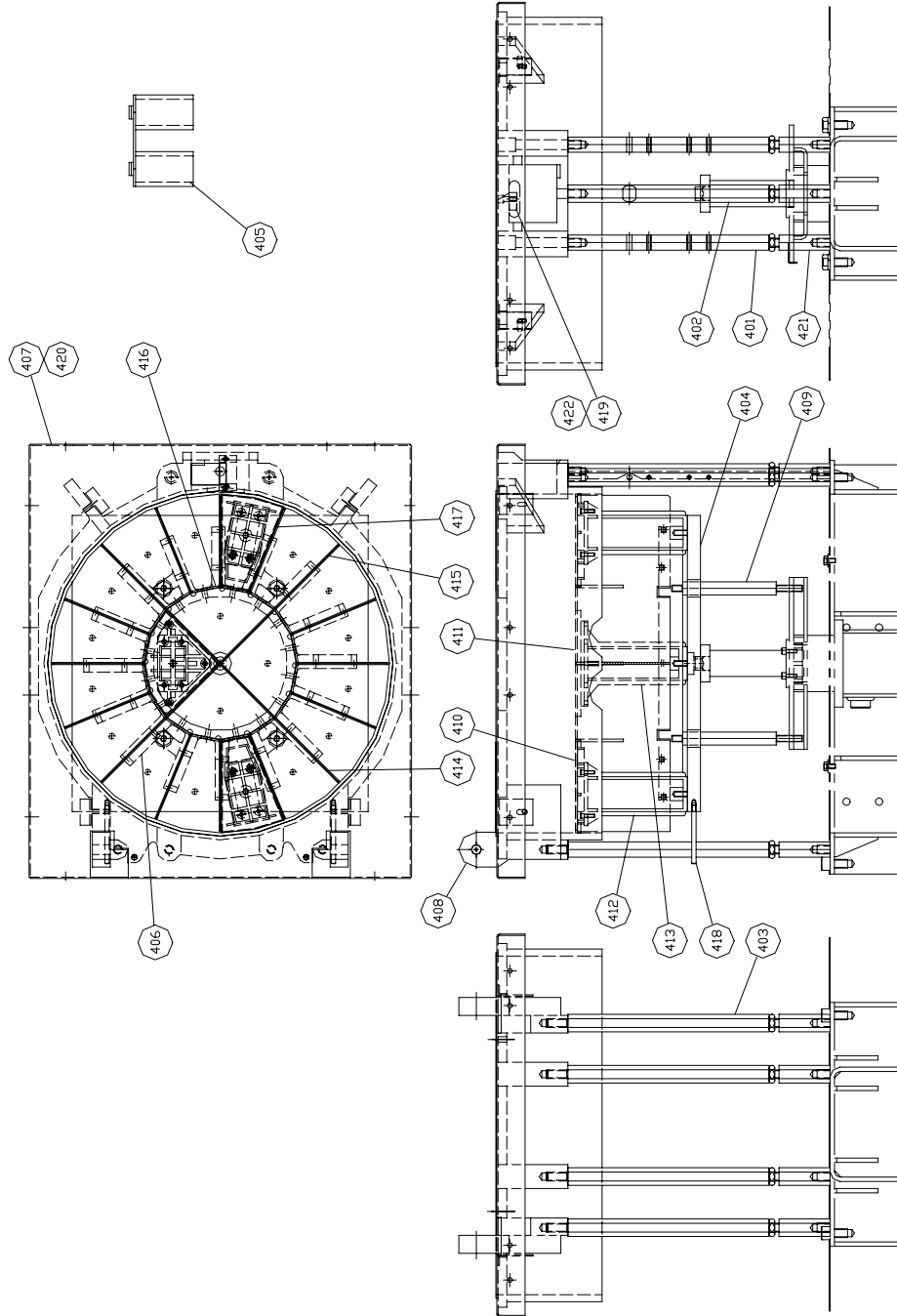



MODEL 619-16, 20, 24, & 24R DOUGH DIVIDERS

24 PART SQUARE PUSHER ASSEMBLY DRAWING

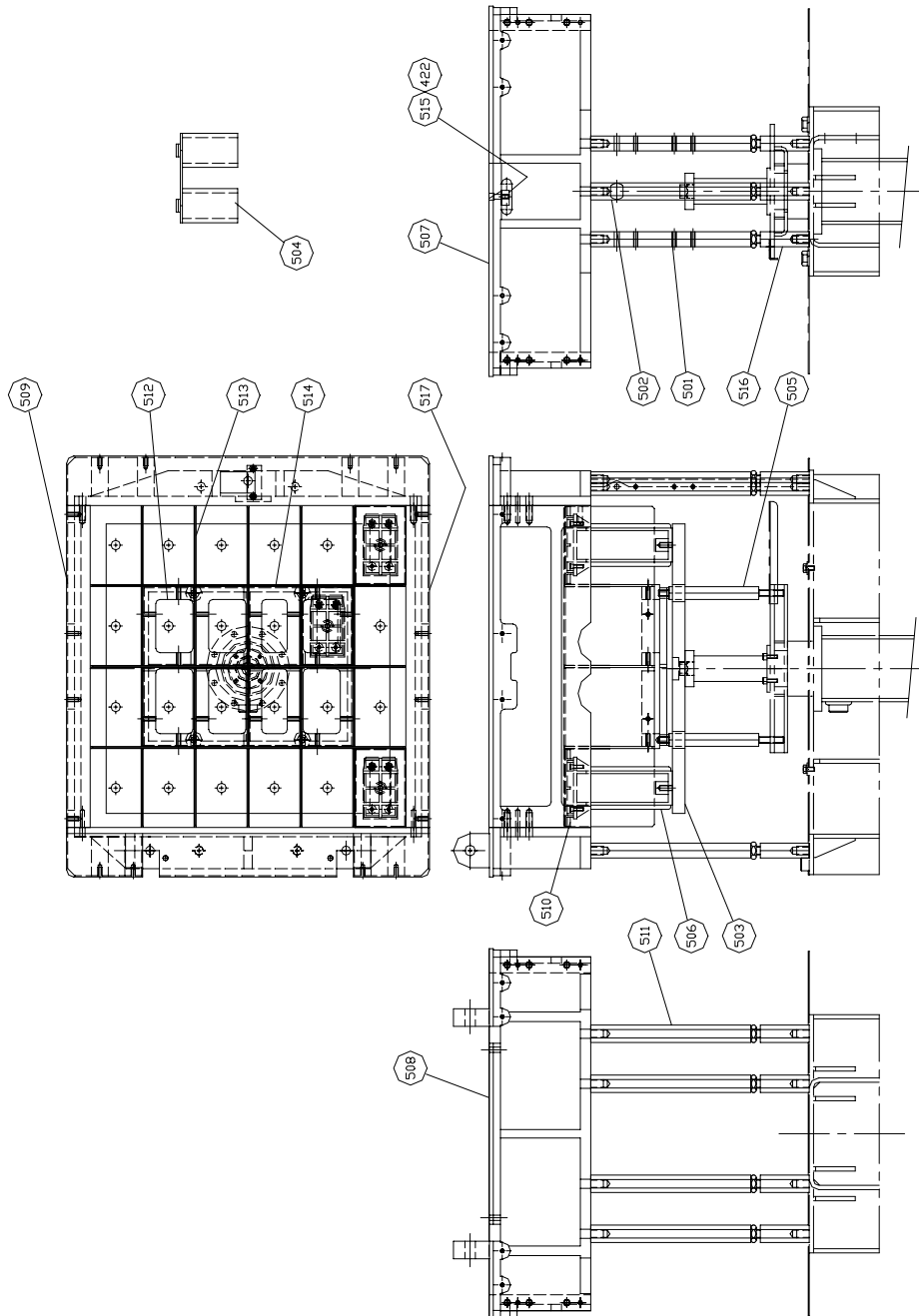



MODEL 619-16, 20, 24, & 24R DOUGH DIVIDERS

24 PART ROUND PUSHER ASSEMBLY DRAWING

