



Grand Rapids, Michigan, U.S.A. 49504-5298

USER'S OPERATING AND INSTRUCTION MANUAL

MODEL 600-R3 SERIES

DOUGH MOULDERS

600-R3S20000-CV



SAFETY INSTRUCTIONS

Various safety devices and methods of guarding have been provided on this machine. It is essential, however, that machine operators and maintenance personnel observe the following safety precautions. Improper installation or operation of this equipment may cause injury to personnel or damage to equipment.

1. Read this manual before attempting to operate your machine. Never allow an untrained person to operate or service this machine.
2. Connect the machine to a properly grounded electrical supply that matches the requirements shown on the electrical specification plate and follow specifications of local electrical codes.
3. Disconnect and lock-out the machine from the power supply before cleaning or servicing.
4. Check and secure all guards before starting the machine.
5. Observe all caution and warning labels affixed to the machine.
6. Use only proper replacement parts.
7. Do not wear loose fitting clothing or loose hair. Shirt tails should be tucked in.
8. Wear proper personal safety equipment.
9. Keep Hands away from the moving parts of this machine while it is in operation.
10. In addition to these general safety instructions, also follow the more specific safety instructions given for the different areas of the machine in the operating instructions.

WARNING

DO NOT USE FOR OTHER THAN ORIGINALLY INTENDED PURPOSE



600-R3

MODEL 600-R3 SERIES DOUGH MOULDERS

INDEX

<u>SECTION</u>	<u>PAGE NO.</u>
1.0 DESCRIPTION/SPECIFICATIONS	1-1
1.1 Description	
1.2 Dimensional Specifications	
1.3 Electrical Specifications	
1.4 Wiring Diagram	
2.0 MACHINE INSTALLATION	2-1
2.1 Electrical Requirements	
2.2 Machine Running Direction	
3.0 OPERATING INSTRUCTIONS	3-1
3.1 Machine Preparation	
3.2 Establishing Settings	
4.0 CLEANING/MAINTENANCE	4-1
4.1 Cleaning	
4.2 Changing the Felt Under the Heavy Mat	
4.3 Changing the V-belt	
4.4 Replacing the Motor	
4.5 Removing Rear Chamber Assembly and Belt	
4.6 Removing the Sheeting Rollers	
4.6.1 Removing the Upper Sheeting Roller	
4.6.2 Removing the Lower Sheeting Roller	
4.7 Replacing the Front Triangular Belt	
4.7.1 Removing the Front Triangular Belt	
4.7.2 Installing the Front Triangular Belt	
5.0 REPLACEMENT PARTS	5-1
5.1 Assembly Drawings	
5.2 Parts List	
5.3 Recommended Spare Parts	
WARRANTY	
WARRANTY PROCEDURE	
RETURNED PARTS POLICY	



600-R3
MODEL 600-R3 SERIES DOUGH MOULDER

1.0 DESCRIPTION / SPECIFICATION

1.1 Description

The moulder stretches dough gently and gradually between two belts revolving in opposite directions and at different speeds. The dough is inserted in a hopper located approximately 54" from the floor (when mounted on the Oliver Moulder stand with casters), which feeds it between three plastic coated sheeting rollers. The sheeting and stretching operations are controlled manually with two levers with easy to read scales. The moulded dough is delivered below the hopper on a felt covered retractable shelf approximately 32" above the floor (when mounted on the Oliver Moulder stand with casters).

All driving cylinders are mounted on sealed bearings which are lubricated at the factory and need no further lubrication. The front belt rotates on three cylinders positioned in a triangular pattern while the rear belt rotates in the opposite direction on two cylinders. The three plastic coated sheeting rollers, (of which the lower one is adjustable), flatten the dough after it is inserted in the hopper.

The moulder is driven by a 3/4 HP open drip proof motor which is easily adjustable for tightening the V-belt drive. The revolving belts are driven by a noiseless gear belt system which never needs lubrication.

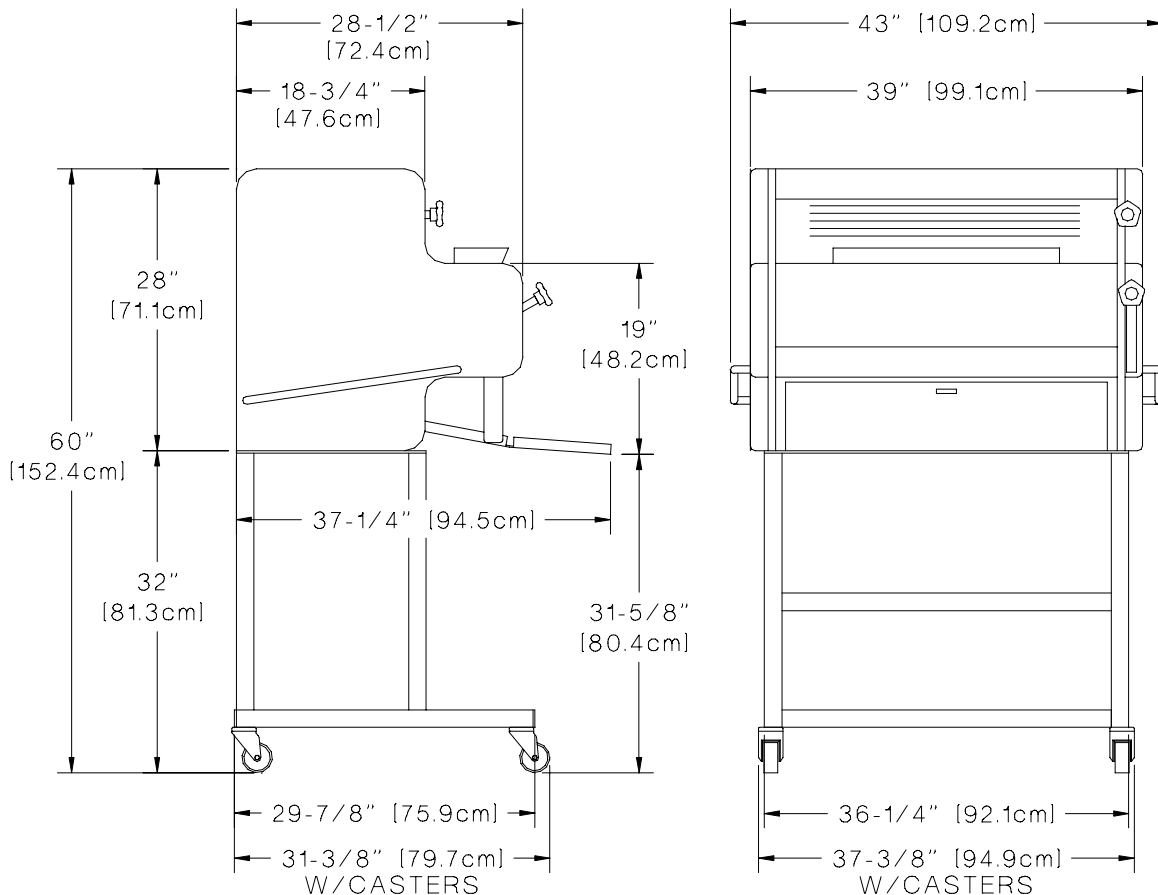

1-1



600-R3

1.2 Dimensional Specifications

Product Capacities:

2 ounces (0.1kg) to 6 pounds (3.0kg)

Net Weight:

Approximately 380 pounds
425 pounds with stand

Shipping Weight:

Approximately 575 pounds

Machine size:

Width = 43 inches
Height = 28 inches,
Height OA = 60 inches
Depth = 28-1/2 inches,
Depth OA = 37-1/4 inches

1.3 Electrical Specifications

208-220/440 Volts AC
3 Phase, 50/60 Hz,
3/4 Horse Power
3.1-3.1/1.5 AMPS.

1.4 Wiring Diagram

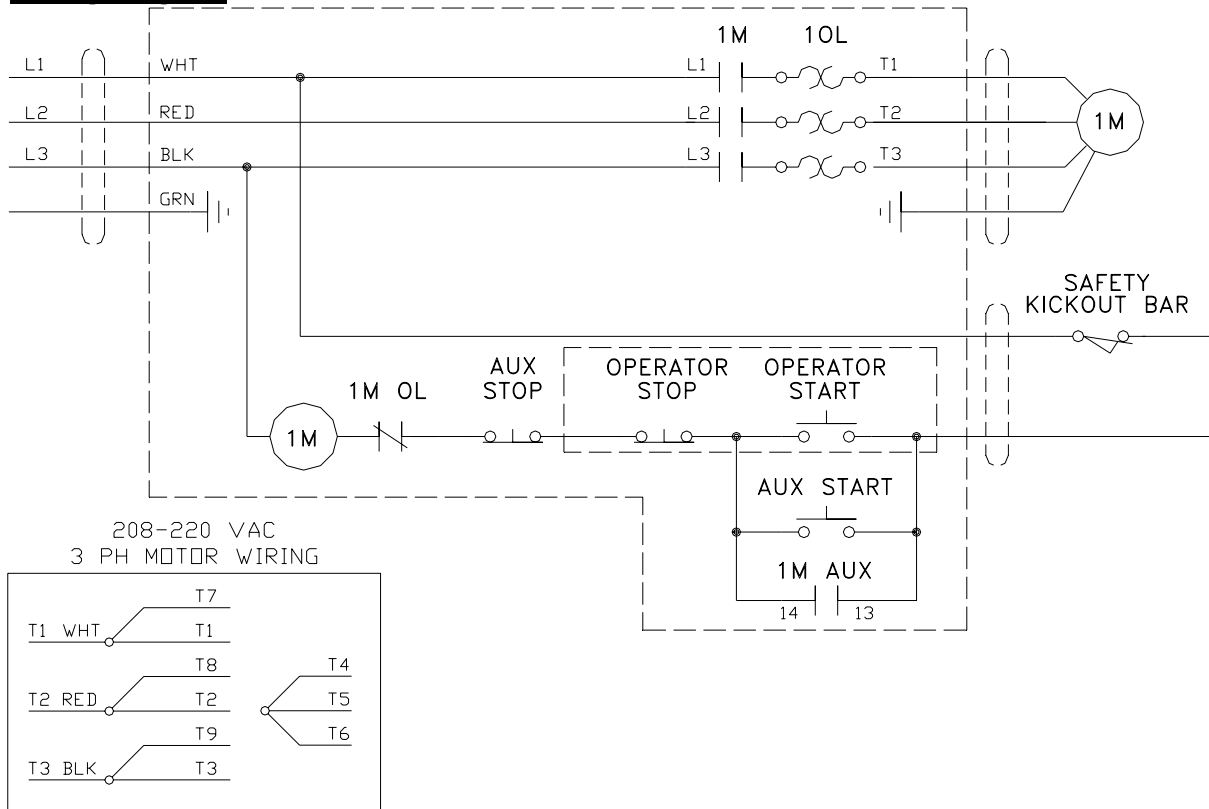



600-R3

MODEL 600-R3 SERIES DOUGH MOULDER

2.0 MACHINE INSTALLATION

2.1 Electrical Requirements

First, check the wall receptacle to be sure it is a three phase, 230 volt receptacle. If not, one must be installed. Attach a three phase, 230 volt plug to the end of the power cord. Be sure the pattern of the wall receptacle and pattern of the plug are matching.

NOTE
A TWIST-LOCK TYPE PLUG MUST BE USED ON THE 600-R3 SERIES OF DOUGH MOULDERS POWER CORD TO KEEP IN COMPLIANCE WITH ETL SAFETY REQUIREMENTS.

Before putting machine into operation, check to see if the machine is running in the correct direction. (See Section 2.2).

2.2 Machine Running Direction

To check for proper running direction you must first disengage the heavy mat, (Item #808, Assembly Drawing 5.1.1) by removing the left and right heavy mat support springs (Item #809, Not Shown) from their posts located towards the top. Lay the heavy mat and under lying felt over the front of machine. Then switch the machine on briefly and observe the direction in which the front triangular belt is moving. If the belt is moving upward the belt rotation is correct. If the belt is moving downward the machine's running direction must be reversed. Unplug the machine from the power receptacle. Reverse the black and white wires in the plug at the end of the power cord.

When the running direction of the machine is correct reinstall the heavy mat.

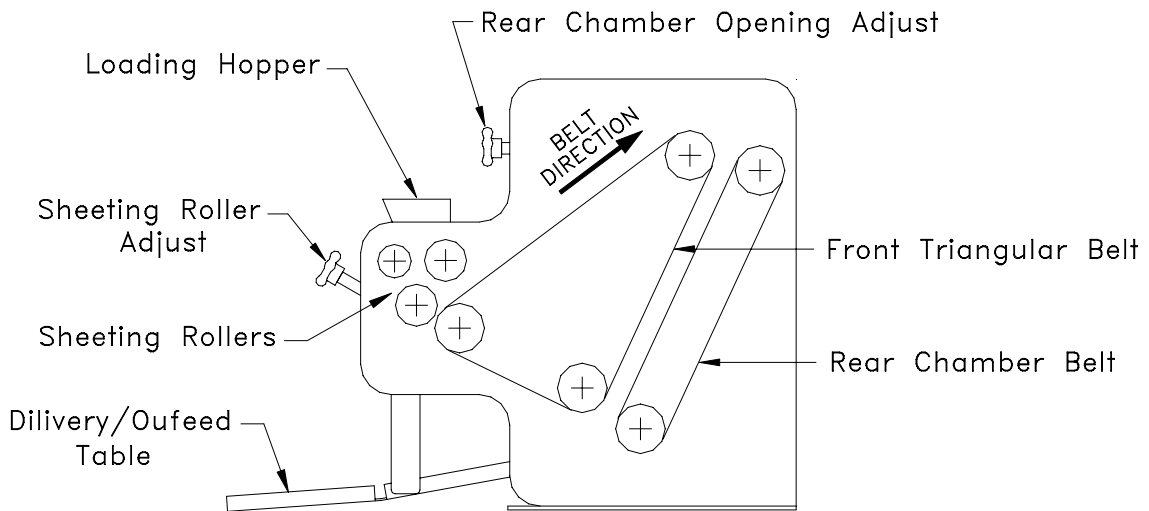

Proper Running Direction



600-R3 SERIES DOUGH MOULDER

3.0 OPERATING INSTRUCTIONS

3.1 Machine Preparation

Always flour the delivery outfeed table felt generously and thoroughly. You should also flour the dough as thickly as possible, all around. Also, when preparing to run the moulder we recommend that you first weigh as many pieces of dough as possible in advance.

3.2 Establishing Settings

NOTE
ADJUSTMENTS SHOULD BE MADE WHILE THE MACHINE IS RUNNING.

Gently drop a piece of dough in the hopper and observe its shape after moulding.

- If the loaf is too compact, open the sheeting rollers.
- If the loaf is not compact enough, close the sheeting rollers.
- If the loaf is too short, close the rear chamber.
- If the loaf is too long, open the rear chamber.
- If the loaf is too fat in the center, close the sheeting rollers while sheeting, or, the dough may be too stiff.
- If the ends twist, open the rear chamber.

We recommend that all settings be recorded for later use once they are established. Remember, results may vary depending on dough condition. If required, make adjustments gradually starting with the original established setting.

ESTABLISHED SETTINGS
FOR SHEETING ROLLERS & REAR CHAMBER OPENINGS

LOAF TYPE	SHEETING	STRETCHING
_____	_____	_____
_____	_____	_____
_____	_____	_____
_____	_____	_____
_____	_____	_____
_____	_____	_____
_____	_____	_____
_____	_____	_____
_____	_____	_____
_____	_____	_____



600-R3 SERIES DOUGH MOULDER

WARNING

ALWAYS MAKE SURE THE MACHINE HAS BEEN DISCONNECTED FROM THE POWER SUPPLY BEFORE CLEANING OR SERVICING.

4.0 CLEANING / MAINTENANCE

4.1 Cleaning

The machine should receive general cleaning at regular intervals with special attention given to the following:

WEEKLY:

- The belts and felt pad on the delivery outfeed table should be thoroughly brushed. Do **NOT** use a metal dough cutter.
- The upper scraper should be removed and cleaned to eliminate scraps of dried dough which might scratch the roller, (section 4.2, procedure 2), for removal of the scraper.

In general the moulder requires little additional maintenance other than that which is specified below. Most of the drives are supplied by either gear belt or V-belt, neither should be lubricated.

4.2 Changing the Felt Under the Heavy Mat

1. Remove the intake cover, (Item #738, Drawing 5.1.1).
2. Remove the two upper scraper tension springs, (Item #816, Drawing 5.1.1), and then disengage the upper scraper, (Item #807, Drawing 5.1.1), by pushing it to the left and lifting it out. Note, the lower scraper is pushed to the right to be remove.
3. Unhook the heavy mat, (Item #808, Drawing 5.1.1), by removing the heavy mat support springs (Item #809, Not Shown), from their post's located towards the top. Lift the heavy mat assembly and under lying felt from their brackets, (Items #813 and #813-1).
4. When replacing the felt under the heavy mat, make sure that the seam is on top and not against the front triangular belt.



600-R3 SERIES DOUGH MOULDER

4.3 Changing the V-Belt

Should the V-belt drive on the motor become loose and begin to slip it can be tightened simply by adjusting the motor bracket frame, see below.

1. Remove the back cover. Remove the orange handle bar (right side only). The two nuts securing the handle bar are located on the inside of the frame. Remove the right side plastic housing, (Item #234, Not shown, Refer to Item #235, Drawing 5.1.1).
2. Loosen the motor adjustment lock down screw.
3. Lift the motor and bracket to allow removal of the belt.
4. To reassemble simply reverse the above procedure.
5. After installing the belt run the machine a few minutes and recheck the belt for proper tightness before replacing the side housing.

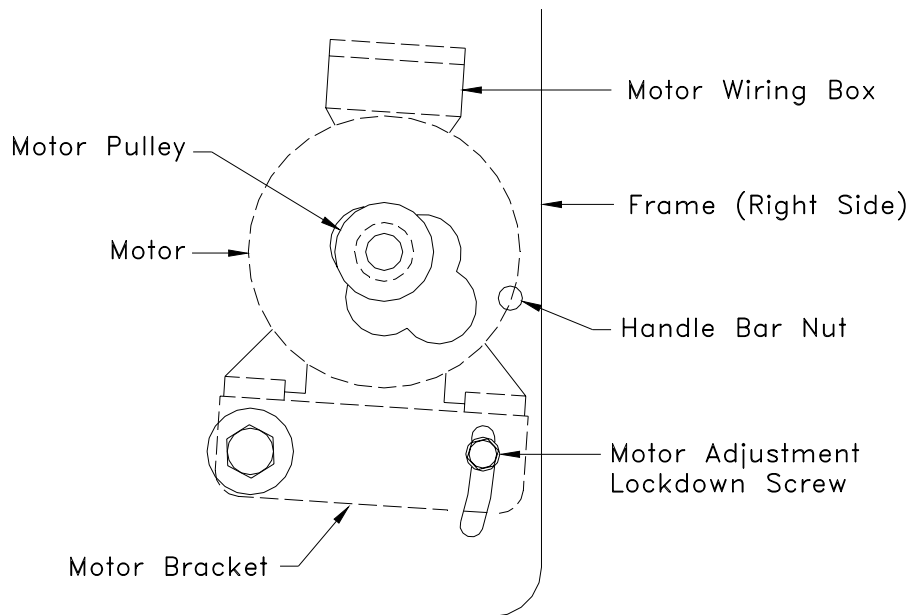

V-Belt and Motor Replacement

4.4 Replacing the Motor

1. Remove the V-belt, (Section 4.3, Procedures 1 through 3).
2. Remove the wires and the pulley from the motor. Remove the screws securing the motor to the motor bracket and then pull the motor out from the machine.
3. Replace the motor by reversing the above procedure. Be sure to check that the replacement motor is rotating in the proper direction before reinstalling the V-belt and covers.



600-R3 SERIES DOUGH MOULDER

4.5 Removing the Rear Chamber Assembly and Belt

1. Remove the back cover. Remove both orange handle bars. The four nuts securing the handle bars are located on the inside of the frame. Remove both side plastic housings, (Items #234 and #235, Drawing 5.1.1).
2. Remove the V-belt, (Section 4.3).
3. Close the rear chamber opening to its maximum, dial reading "0". Remove the timing belt (Item #327, Drawing 5.1.2), by pushing the belt tensioning arm, (Item #312, Drawing 5.1.2) by hand to slacken the belt. Remove timing belt from the timing pulleys.
4. Remove the timing belt pulley, (Item #306, Drawing 5.1.2).
5. Move the chamber so that the lower pivot screws, (Item #112, Not shown, Refer to upper pivot screws, Drawing 5.1.1), are lined up with the holes in the frame. Remove both the right hand and left hand lower pivot screws. At this time you should secure the chamber's weight with pieces of wood. After securing the chamber, remove the upper right and left hand pivot screws, (Item #112, Drawing 5.1.1), freeing the upper connecting rods. By tilting the chamber slightly the lower connecting rods can be dislodged. The chamber can now be removed by first moving it to the left so the drive cylinder shaft clears the frame and then lifting it out from the machine. The rear chamber assembly can then be placed on a convenient work surface.
6. Remove outfeed flap, (Item #707, Drawing. 5.1.1), located at the bottom of the rear chamber assembly.
7. Remove left upper tab, (Item #105, Not shown, refer to Item #106, Drawing 5.1.1) Tab will need to be pried after screws have been removed.
8. Remove both left and right tension stirrups, (Item #103, Drawing 5.1.1), and then slide the rear chamber tension cylinder, (Item #111, Drawing 5.1.1), out from the rear chamber belt.
9. Slide rear chamber belt, (Item #108, Drawing 5.1.1), from rear chamber assembly.
10. Replace rear chamber belt. Reassemble rear chamber assembly by reversing the above procedures 6 through 8. Be sure to tighten both tension stirrups equally. Do not over tighten belt.



600-R3 SERIES DOUGH MOULDER

4.6 Removing the Sheeting Rollers

1. Remove the covers and timing belt, (Section 4.5, Procedures 1 and 3), “Removing the Rear Chamber”.
2. Remove the intake cover, (Item #738, Drawing 5.1.1). Note, on some models, once the knobs have been removed, the intake cover can be tilted out allowing access to the sheeting rollers with out removing cover entirely.
3. Remove the third sheeting roller, (Item #820, Drawing 5.1.1).

4.6.1 Removing the Upper Fixed Sheeting Roller

1. Follow all the procedures in section 4.6.
2. Remove the left and the right upper scraper tension springs, (Item #816, Drawing 5.1.1), and then disengage the upper scraper (Item #807, Drawing 5.1.1), by pushing it to the left and lifting it out.
3. Remove the tension spring connected to the timing belt tensioner arm, (Item #312, Drawing 5.1.2), at the screw post just above the upper sheeting roller bearing housing, (Item #209, Drawing 5.1.2), and let tensioner pulley assembly hang freely.
4. Remove the upper timing belt pulley, (Item #325, Drawing 5.1.2) from the left end of the roller.
5. Remove the switch operator arm, (Item #734, Drawing 5.1.3) located to the right of the roller.
6. Remove the three screws securing the right hand bearing housing, (Item #210, Drawing 5.1.3), letting the limit switch, (Item #733, Drawing 5.1.3), and support bracket hang. Do **NOT** remove the wiring from the switch.
7. Remove the three screws securing the left bearing housing, (Item #209, Drawing 5.1.2).
8. Slide the sheeting roller, bearings, and bearing housings to the left about 8”. Remove the small retaining snap ring from the right end of the roller shaft. Using a puller, remove the right hand bearing and bearing housing. The upper sheeting roller can now be removed from the machine by sliding it completely to the left through the clearance hole in the frame.
9. Reassemble by reversing the above procedure



600-R3 SERIES DOUGH MOULDER

NOTE

ALWAYS REPLACE THE BEARINGS WITH NEW ONES WHENEVER THEY HAVE BEEN REMOVED FROM MACHINE.

4.6.2 Removing the Lower Adjustable Sheeting Roller

1. Follow all the procedures in section 4.6. The intake cover will need to be completely removed at this time.
2. Remove the left and right lower scraper tension springs, (Item #811, Drawing 5.1.1), and then disengage the lower scraper (Item #804, Drawing 5.1.1) by pushing it to the right and lifting it out.
3. Remove the lower timing belt pulley, (Item #325, Drawing 5.1.2) from the left end of the roller
4. Loosen the screw on the left hand rocking device, (Item #212, Drawing 5.1.2) that locks the left hand bearing in place.
5. Remove the small retaining snap rings from both ends of the roller shaft. Using a puller, push the right end of the roller shaft out of the right hand bearing. Once the left hand bearing has cleared the left hand rocking device, remove the left hand bearing. The lower sheeting roller can now be removed from the machine by pushing the roller to the left until the right end is free. Lift the right end of roller out from the machine and slide the roller completely to the right and out from the machine.
6. Reassemble by reversing the above procedure.

NOTE

ALWAYS REPLACE THE BEARINGS WITH NEW ONES WHENEVER THEY HAVE BEEN REMOVED FROM MACHINE.



600-R3 SERIES DOUGH MOULDER

4.7 Replacing the Front Triangular Belt

4.7.1 Removing the Belt

1. To change the front triangular belt you should remove the following items referring to the appropriate section; Heavy mat (Section 4.2), V-belt (Section 4.3), Rear chamber Assembly (Section 4.5), and the Adjustable lower sheeting roller (Section 4.6.2). The stationary upper sheeting roller does not have to be removed.
2. Remove the left and right belt guides, (Items #708 & #709, Drawing 5.1.1).
3. **Lower Tension Cylinder** (Item #318, Drawing 5.1.1) -Remove the right and left lower tension stirrups, (Item #103, Drawing 5.1.1), from the lower tension cylinder, (Item #318, Drawing 5.1.1). Push the tension cylinder all the way to the left, lift and remove through the opening in the right side frame.
4. **Upper Drive Cylinder** (Item #316, Drawing 5.1.1) -Remove the V-belt pulley, (Item #215, Drawing 5.1.3). Remove the (3) screws from the left bearing housing, (Item #208, Drawing 5.1.2), at the left end of the upper drive cylinder, (Item #316, Drawing 5.1.1), and the (3) screws from the right bearing housing (Item #210, Not shown) at the right end of the drive cylinder. Remove the drive cylinder through the opening in the left side frame.
5. **Front Bearing Plate** (Item #710, Drawing 5.1.1) -Remove the (2) snap rings from the right or left end of the front bearing plate support rod, (Item #714, Not shown) located at the top of the bearing plate. With a hammer and punch, tap the support rod all the way out the opposite side of the frame. Remove the (2) bolts and cylindrical nuts located on both sides at the bottom of the bearing plate. Remove the front bearing plate, (Item #714, Not shown) through the opening in the right side frame.
6. **Rear Bearing Plate** (Item #711, Drawing 5.1.1) -Remove the rear chamber retention spring, (Item #109, Drawing 5.1.3). Remove the (2) hex nuts and bolts from the rear chamber adjustment pillow block, (Item #641, Drawing 5.1.3). Remove the rear chamber adjustment screw assembly as a whole, including; (Items #631, 633, 634 and 641, Drawing 5.1.3). Also remove the drive pin for the rear chamber adjusting lever. Remove the (2) snap rings from the right or left end of the rear bearing plate support rod, (Item #716, Drawing 5.1.1) located at the bottom of the bearing plate. With a hammer and punch, tap the support rod all the way out the opposite side of the frame. Lift the rear bearing plate, (Item #711, Drawing 5.1.1) from the rear chamber connecting rod shaft and remove through the opening in the right side frame.

Upper Connecting Rods (Item #314, Drawing 5.1.1) -Remove the (3) screws from the bearing housing, (Item #210, Drawing 5.1.2) at the left end of the upper connecting rod shaft, (Item #314, Drawing 5.1.1). Remove the connecting rods and shaft through the opening in the left side frame.



600-R3 SERIES DOUGH MOULDER

4.7.1 Removing the Front Triangular Belt cont'd

8. **Front Idle Cylinder** (Item #317, Drawing 5.1.1) -Remove the retaining snap rings from both ends of the front idle cylinder shaft. Remove the left side rocker device, (Item #212, Drawing 5.1.2). Remove the (3) screws from the bearing housing, (Item #207, Drawing 5.1.2), at the left end of the front idle cylinder, (Item #317, Drawing 5.1.1). Push the cylinder to the left and remove through the opening in the frame on the left side.
9. The old belt may now be removed.

4.7.2 Installing the Belt

1. Place the new belt in between the side frames. Make sure the belt will rotate in the direction shown by the arrow on the belt, (See section 2.2 for machine's proper running direction).
2. Replace the following items by reversing the disassembly procedures. We suggest that you do so in the following order. Replace the Upper connecting rod Item #314, Front bearing plate Item #714, Rear bearing plate Item #711, Upper drive cylinder Item #316, Front idle cylinder Item #317, and the Lower tension cylinder Item #318.
3. Tighten the belt using the lower tension screws, (Item #103, Drawing 5.1.1), Making the same number of turns for each screw on each side of the machine. Do not over tighten the belt.
4. Again by reversing the disassembly procedures, replace the following referring to the appropriate section; The Lower adjustable sheeting roller and third sheeting roller (Section 4.6), The Rear chamber assembly, Timing belt and Timing pulleys (Section 4.5), The Motor (Section 4.4), and The V-belt (Section 4.3).

NOTE

TIMING PULLEYS MUST BE IN LINE WITH EACH OTHER FOR PROPER MACHINE OPERATION.

5. Restart the machine. With the machine running, brake the belt with your hand to check that it does not slip. If the belt slips tighten the tensions screws a few more turns equally on each side of the machine. If the belt starts to travel to the left or right, tighten the tension screw on the side the belt is traveling towards. Once the belt does not travel to the left or right, complete the setting of the belt tension by giving each tension screw a final 1/4 turn. Remember to not over tighten the belt.
6. Replace the left and right belt guides Items #708 and #709 along with the four bearings (revolving washers) Item #245 located underneath the belt guides.
7. Replace the heavy belt Item #808.



MODEL 600-R3 SERIES DOUGH MOULDER

5.1.2 Assembly Drawings cont'd

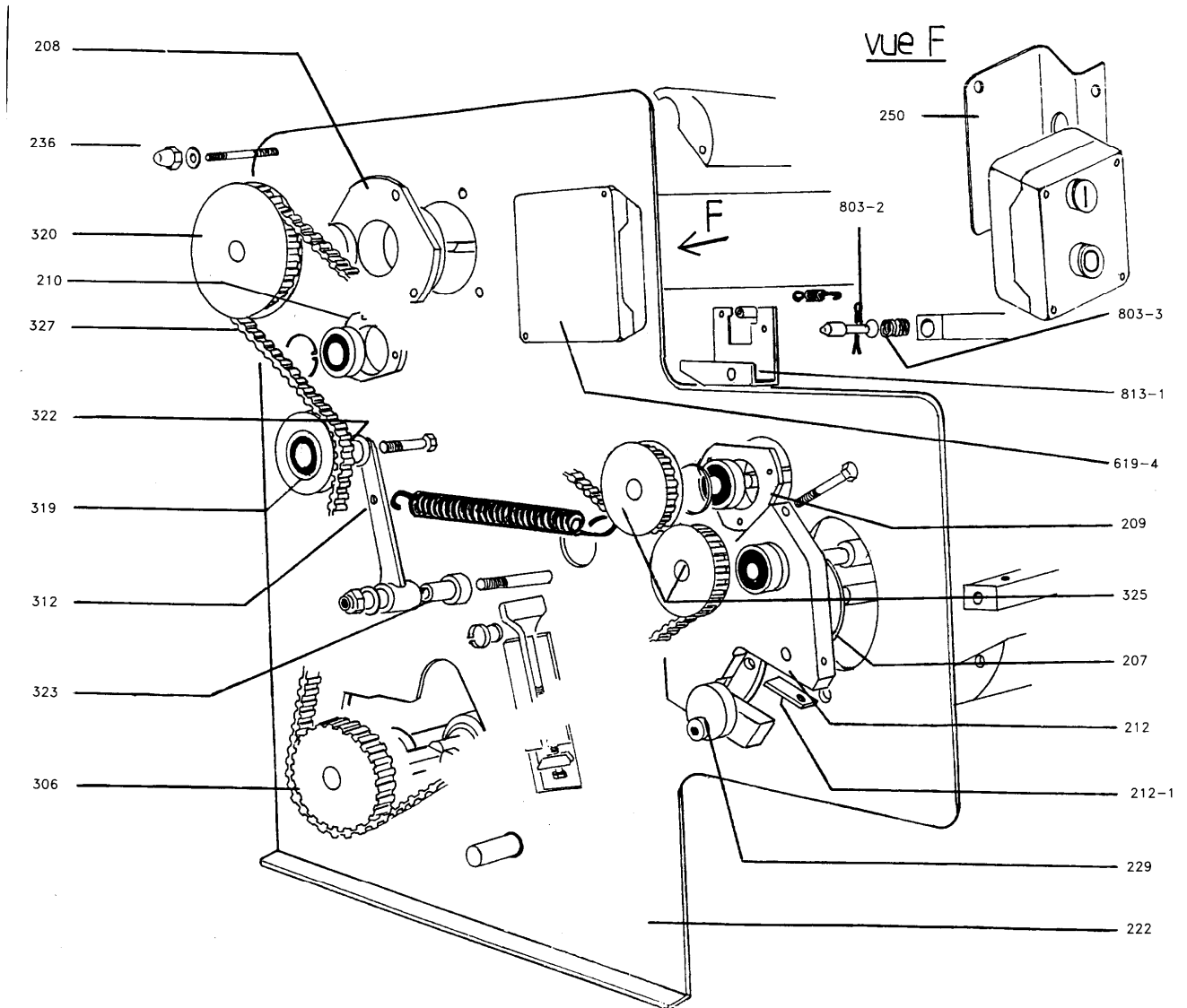



MODEL 600-R3 SERIES DOUGH MOULDER

5.1.3 Assembly Drawings cont'd

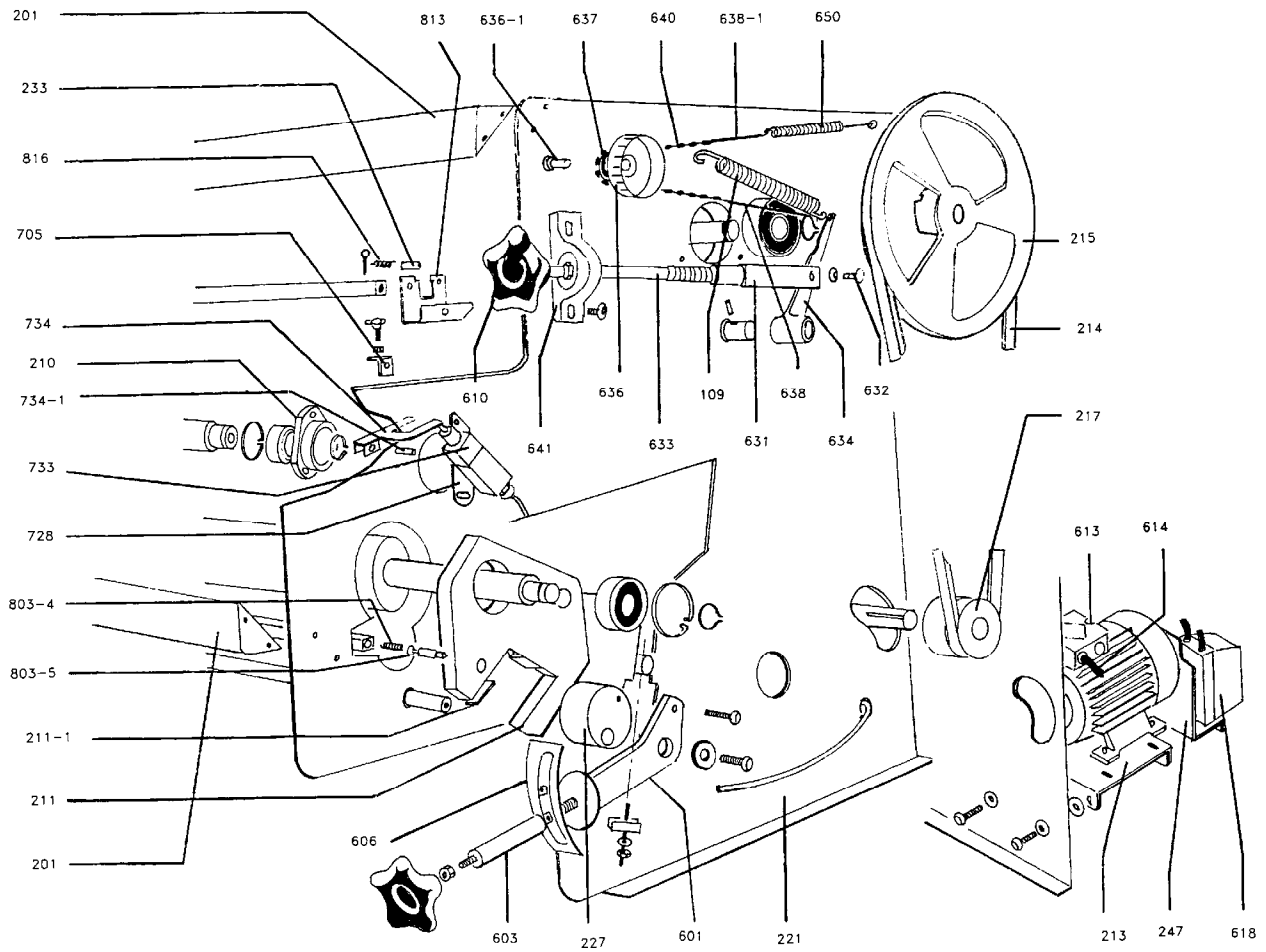

FIGURE 3/3



MODEL 600-R3 SERIES DOUGH MOULDER

5.2 Parts List

<u>BALLOON NO.</u>	<u>PART DESCRIPTION</u>	<u>PART NO.</u>
BEARINGS		
-----	Bearing 6004-2RS	5210-4040
-----	Bearing 6204-2RS	5220-4040
CHAMBER PARTS		
102	Rear chamber frame	P42102
103	Tension stirrup - Front & Rear belt	0600-0009
* 105	Upper tab, left side	P42105
106	Upper tab, right side	P42106
108	Belt 105cm x 77cm - Rear chamber (600-R3)	6824-3050
108	Belt - Rear Synthetic (600-R3S)	6824-3112
109	Spring - Rear chamber retention (and) Idler pulley retention	6824-3057
110	Drive cylinder - Rear chamber (Bearing 6004 2RS)	6824-3073
111	Tension cylinder - Rear chamber (Bearing 6204 2RS)	6824-3074
112	Connecting rod pivot screw	P42112
114	Lower tab, right side	P42114
* 115	Lower tab, left side	P42115
117	Back belt guide	P42117
FRAME PARTS		
201	Frame cross member	P42201
207	Bearing housing - Idle cylinder	P42207
208	Bearing housing - Drive cylinder	6824-3080
209	Bearing hsg. - Stationary sheeter left	P42209
210	Bearing hsg. - Stationary sheeter right (and) Rear chamber connecting rod	6824-3081
211	Right rocker device	P42211
211-1	Right rocker device bearing plate	P42211-1
212	Left rocker device	P42212
212-1	Left rocker device bearing plate	P42212-1
213	Motor mounting bracket	P21213
214	V-belt Poly-V 1280J	6842-3102
215	Pulley - Drive	P42215
217	Pulley - Motor	P42217
221	Frame - Right side	P42221
222	Frame - Left side	P42222
223	Belt 122cm x 79cm - Front (Triangular) (600-R3)	6824-3051
223	Belt - Front synthetic (600-R3S)	6824-3113

**Part not shown with balloon number on assembly drawings*



FRAME PARTS....cont'd

226	Sheeter cam shaft	P42226
227	Control cam	P42227
* 228	Cam ring	P42228
229	Adjustment Cam	P42229
233	Scraper tension spring post	P42233
* 234	Plastic housing - Right side	6824-3099
235	Plastic housing - Left side	6824-3100
236	Side housing mounting screws	P42236
245	Bearing 626-2RS (Revolving Washer)	P42245
247	Motor starter mounting bracket	P42247
250	Switch mounting bracket	P42250

BELT DRIVE PARTS

306	Pulley - Timing 28 HO75 - Rear chamber	6824-3128
312	Belt tensioner arm	P42312
313	Lower connecting rods - Rear chamber	P42313
314	Upper connecting rods - Rear chamber (Bearing 6004 2RS)	P42314
316	Drive cylinder (Upper) - Triangular belt (Bearing 6204-2RS)	6824-3075
317	Idle cylinder (Front) - Triangular belt (Bearing 6204-2RS)	6824-3076
318	Tension cylinder (Lower) - Triangular belt (Bearing 6204-2RS)	6824-3077
319	Pulley - Belt tensioner (Bearing 6004-2RS)	P42319
320	Pulley - Timing 18 HO75 - Drive cylinder	P42320
322	Axle, bearing	P42322
323	Belt tensioner mounting shaft	P42323
325	Pulley - Timing 14T - Upper & Lower sheeter	6824-3082
327	Belt - Timing D700H075	6824-3136

OUTFEED TABLE PARTS

401	Hinged outfeed table door	P42401
402	Felt - Outfeed table (600-R3)	6824-3072
402	Belt - Outfeed table, synthetic (600-R3S)	6824-3114
403	Right outfeed table support bracket	P42403
403-1	Left outfeed table support bracket	P42403-1
407	Outfeed table door catch pin	P42407
410	Outfeed table door hook latch	P42410

* Part not shown with balloon number on assembly drawings.



MANUAL CONTROL PARTS

601	Sheeting control lever	P42601
603	Sheeting lever lock down rod	6824-3064
606	Lever guide / Lock plate	6824-3096
610	Star knob	6824-3090
631	Rear chamber adjusting arm	6824-3124
632	Arm retaining pin	6824-3125
633	Rear chamber adjusting screw	6824-3126
634	Rear chamber adjusting lever	P42634
636	Dial - Rear chamber opening	P42636
636-1	Dial mounting pin	P42636-1
637	Dial sprocket	P42637
638	Lower spring extension wire - Dial	P42638
638-1	Upper spring extension wire - Dial	P42638-1
640	Dial chain	P42640
641	Pillow Block - Rear chamber adjust	6824-3127
650	Spring - Dial chain extension	7022-4001

ELECTRICAL PARTS

613	Motor 3/4 HP 3/60/220-240	6824-3078
614	Power cord	P42614
618	Motor starter disconnect switch	5709-3122
	Overload relay - Motor starter	5750-1276
	Contactor - Motor starter	5749-8286
619-4	On / Off switch	5720-4200

MISCELLANEOUS PARTS

702	Felt - Outfeed flap (600-R3)	6824-3071
702	Belt - Outfeed flap synthetic (600-R3S)	6824-3115
703	Loading hopper	6024-3155
705	Intake cover bracket	6824-3123
707	Outfeed flap	P42707
707-1	Flap pin	P42707-1
708	Belt guide, right	P42708
* 709	Belt guide, left	P42709
710	Front bearing plate	P42710
711	Rear bearing plate	P42711
* 714	Support rod - Front bearing plate	P42714
716	Support rod - Rear bearing plate	P42716
728	Limit switch support	P42728
729	Safety kickout bar	6824-3118
733	Limit Switch - Safety kickout	5757-7356
734	Switch operator arm	P42734
734-1	Switch arm mounting tube	P42734-1
737	Spring - Safety kickout bar	7023-3100
738	Intake cover	6824-3156
738-1	Safety bar bracket	6824-3157
740	Handle bar	6824-3122

* Part not shown with balloon number on assembly drawings.



SHEETER / SCRAPER / HEAVY MAT PARTS

801	Sheeting Roller - Stationary (Bearing 6004-2RS)	6824-3065
802	Sheeting Roller - Adjustable (Bearing 6004-2RS)	6824-3066
803	Lower scraper mounting square	0600-0004
* 803-1	Upper scraper mounting square	0600-0003
803-2	Upper scraper end pin	0600-0005
803-3	Spring - Upper scraper end pin	7012-2008
803-4	Spring - Lower scraper end pin	7012-2008
803-5	Lower scraper end pin	0600-0006
804	Blade - Lower scraper	6824-3056
805	Heavy mat rods	6824-3095
805-1	Heavy mat upper support rod	P42805-1
805-2	Heavy mat rod	P42805-2
806	Felt under heavy mat (600-R3)	6824-3070
806	Belt under heavy mat, synthetic (600-R3S)	6824-3116
807	Blade - Upper scraper	6824-3055
808	Heavy mat	6824-3101
* 809	Spring - Heavy mat support	6824-3117
810	Heavy mat lower support rod	P42810
811	Spring - Lower scraper tension	7022-4118
813	Heavy mat & scraper bracket, right	P42813
813-1	Heavy mat & scraper bracket, left	P42813-1
816	Spring - Upper scraper tension	6824-3058
820	Sheeting Roller - Third	6824-3129
821	Pulley - Sheeting rollers	P42438-1
822	Belt-Roll Drive	6824-3108

STAND PARTS

* ----	Right side	6824-3083
* ----	Left side	6824-3084
* ----	Caster 80(mm) Dia.	6824-3085
* ----	Cross tube 30(mm) Dia.	6824-3086
* ----	Rear Panel	6824-3088
* ----	Rack/shelf	6824-3089

* Part not shown with balloon number on assembly drawings.



5.3 Recommended Spare Parts

<u>PART NO.</u>	<u>PART DESCRIPTION</u>	<u>QUANTITY</u>
5709-3122	Motor Starter	1
5210-4040	Bearing 6004-2RS	1
5220-4040	Bearing 6204-2RS	1
5601-4072	Belt - Timing	1
5757-7356	Limit Switch	1
0600-25000	Upper Scraper Unit	1
6824-3058	Spring - Upper Scraper Tension	2
7022-4118	Spring - Lower Scraper Tension	2
6824-3117	Spring - Heavy mat support	2
6824-3065	Fixed Roller	1
6824-3066	Adjustable Roller	1
0600-25003	Lower Scraper Unit	1
6824-3055	Blade - Upper Scraper	1
6824-3056	Blade - Lower Scraper	1
6824-3102	Belt-Poly V 1280J	1

Model 600-R3

6824-3050	Belt - Rear	1
6824-3051	Belt - Front (Triangular)	1
6824-3070	Felt - Under Heavy mat	1
6824-3071	Felt - Outfeed Flap	1
6824-3072	Felt - Outfeed Table	1

Model 600-R3S

6824-3112	Belt - Rear synthetic	1
6824-3113	Belt - Front synthetic	1
6824-3114	Belt - Under Heavy mat, sythetic	1
6824-3115	Belt - Outfeed Flap, synthetic	1
6824-3116	Belt - Outfeed Table, synthetic	1