



Key Features:

- Versatile grille for sandwiches, quesadillas, meats, vegetables, breakfast items
- Self-leveling top platens
- Easy-to-use operator controls are located on the front panel for easy viewing
- Easy to clean
- Removable front grease trough for easy clean up
- Analog temperature dial for easy adjustment
- Cooking temperature range: 120° – 570° F



Model 502-N shown with standard 4" adjustable legs and optional timers



Oliver Packaging & Equipment Company
511 Sixth Street NW • Grand Rapids, MI 49504
(800) 253-3893 • (616) 356-2950 • www.oliverquality.com



Manufactured in the U.S.A.

**Packaging - Processing
Bid on Equipment**
1-847-854-8577
www.bid-on-equipment.com



Oliver Panini Grille

SPECIFICATIONS

Capacities:

Self leveling platen can accept up to 4" high product

Electrical:

502-N

1-50/60 Hz - 208/240 V, 20 AMPS

Finish:

Stainless steel with cast iron grille surfaces

Dimensions

9" upper platen (see drawings at right):

Shipping weight:

Model 502-N 135 lbs (54kg)

Net Weight:

Model 502-N 105 lbs. (48 kg)

Options:

(all options are not available on all models)

- Smooth top and bottom platens
- 2.5" suction cupped, adjustable legs
- Digital Timers
- 4" flanged, adjustable legs
- 2.5" flanged, adjustable legs
- 4" suction cupped, adjustable legs
- Table stops

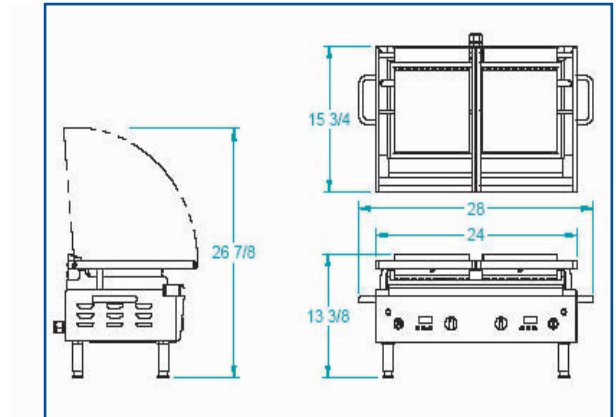

The information contained herein is correct to the best of our knowledge. The recommendations or suggestions are made without guarantee or representation as to results. Freedom from any patent owned by Oliver Packaging and Equipment or other is not to be inferred.

Above specifications subject to change without notice

Manufactured in the U.S.A.



Oliver Packaging & Equipment Company
511 Sixth Street NW • Grand Rapids, MI 49504
(800) 253-3893 • (616) 356-2950 • www.oliverquality.com

Packaging - Processing
Bid on Equipment
1-847-854-8577
www.bid-on-equipment.com