



Grand Rapids, Michigan, U.S.A. 49504-5298

USER'S OPERATING AND INSTRUCTION MANUAL

MODELS 501, 501-N, 502, & 502-N

PANINI GRILLS

0502S20000



501_502

INDEX

<u>Section Description</u>	<u>Document No.</u>	<u>Page No.</u>
SAFETY INSTRUCTIONS -----	0502S20002 -----	1-1
DESCRIPTION/SPECIFICATIONS -----	0502S20003 -----	2-1
Description -----		2-1
Specifications -----		2-1
INSTALLATION INSTRUCTIONS -----	0502S20004 -----	3-1
Container Inspection -----		3-1
Location Selection & Electrical Hook-up -----		3-1
Ventilation and Clearances -----		3-1
Initial Set-up -----		3-2
Upper Platen Assist Spring Adjustment -----		3-2
Seasoning of the Cooking Surface -----		3-2
OPERATING INSTRUCTIONS -----	0502S20005 -----	4-1
Preheating -----		4-1
Temperature Selection -----		4-1
Setting the "Optional" Timer -----		4-1
Operating Hints -----		4-2
TROUBLESHOOTING -----	0502S20006 -----	5-1
The Grille is not Heating (Indicator Light <u>Is Not</u> On) -----		5-1
The Grille is not Heating (Indicator Light <u>Is</u> On) -----		5-1
Product is Either Burning or Under Cooking -----		5-2
The Upper Platen Falls If not Held -----		5-2
The Optional Timer Does Not Turn On (The Rest of the Units is Working) -----		5-2
MAINTENANCE -----	0502S20007 -----	6-1
Upper Platen Assist Spring Adjustment -----		6-1
Cleaning -----		6-1
RECOMMENDED SPARE PARTS -----	0502S20008 -----	7-1
REPLACEMENT PARTS SECTION		
MODEL 501 PANINI GRILLES -----	0501S20000 -----	8-1
Drawing -----		8-1
Parts List -----		8-2
MODEL 502 PANINI GRILLES -----	0502S20009 -----	9-1
Drawing -----		9-1
Parts List -----		9-2

Continued



Oliver Packaging & Equipment Company
 511 Sixth Street NW • Grand Rapids, MI 49504

(800) 253-3893
 www.oliverquality.com

501_502

INDEX (Continued)

<u>Section Description</u>	<u>Document No.</u>	<u>Page No.</u>
MODEL 501 PANINI GRILLE WIRING DIAGRAMS -----	0501S20001 -----	10-1
1-50/60-208/220/240 With Timer -----		10-1
1-50/60-208/220/240 Without Timer -----		10-1
1-50/60-110/115 With Timer -----		10-2
1-50/60-110/115 Without Timer -----		10-2
 MODEL 502 PANINI GRILLE WIRING DIAGRAMS -----	 0502S20010 -----	 11-1
1-50/60-208/220/240 With Timers -----		11-1
1-50/60-208/220/240 Without Timers -----		11-2
 WARRANTY -----	 GEN 050816	
WARRANTY PROCEDURE-----	GEN 050817	
RETURNED PARTS POLICY -----	GEN 050818	



501_502

GENERAL SAFETY INSTRUCTIONS

WARNING

IT IS ESSENTIAL THAT ALL GRILLE OPERATORS AND MAINTENANCE PERSONNEL OBSERVE THE FOLLOWING SAFETY PRECAUTIONS. IMPROPER INSTALLATION, MAINTENANCE, OR OPERATION OF THIS EQUIPMENT COULD CAUSE SERIOUS INJURY OR DEATH.

1. Read this manual before attempting to operate your grille. Never allow an untrained person to operate or service this appliance.
2. Connect the grille to a properly grounded electrical supply that matches the requirements shown on the grille's electrical specification plate. Follow all local building and electrical codes.
3. Do not install this appliance on or near flammable surfaces or materials including curtains, draperies, walls etc.
4. Do not "Wash Down" or Immerse this appliance in water or other liquids.
5. Disconnect and lock-out the grille from the power supply before cleaning or servicing.
6. Observe all caution and warning labels affixed to the grille.
7. Use only proper replacement parts.
8. Wear proper, personal, protective, safety equipment.
9. Keep Hands away from the heated parts of this appliance until it has been allowed to cool.
10. In addition to these general safety instructions, please follow the more specific safety instructions in the rest of this operating and instruction manual.

WARNING

DO NOT USE FOR OTHER THAN ORIGINALLY INTENDED PURPOSE.



501_502

DESCRIPTION/SPECIFICATIONS

Description

The Oliver Models 501 & 501-N, (Single Top Platen), and Models 502 & 502-N Double Top Platen Grilles are constructed of stainless steel with cast iron cooking surfaces. The floating, (self leveling), top platen will remain roughly parallel to the bottom platen to a height of approximately four inches.

The heated surfaces are thermostatically controlled with separate selection of either heated bottom platen only or heating of both top and bottom platens. An optional timer is also available.

The Oliver Panini Grilles, depending on the options you have selected, can be used to prepare Quesadillas, "Panini" or gourmet sandwiches. They can grille meats, vegetables, breakfast items like, eggs, pancakes, or French toast. They can also toast bagels and breads or be used in many other applications.

Oliver Products Company, has served the Food Machinery Industry for over 70 years, and we stand behind these grilles.

Specifications

Space Requirements, (Shown with Standard Options):

Model 501 & 501-N (All Dimensions are Approximate)

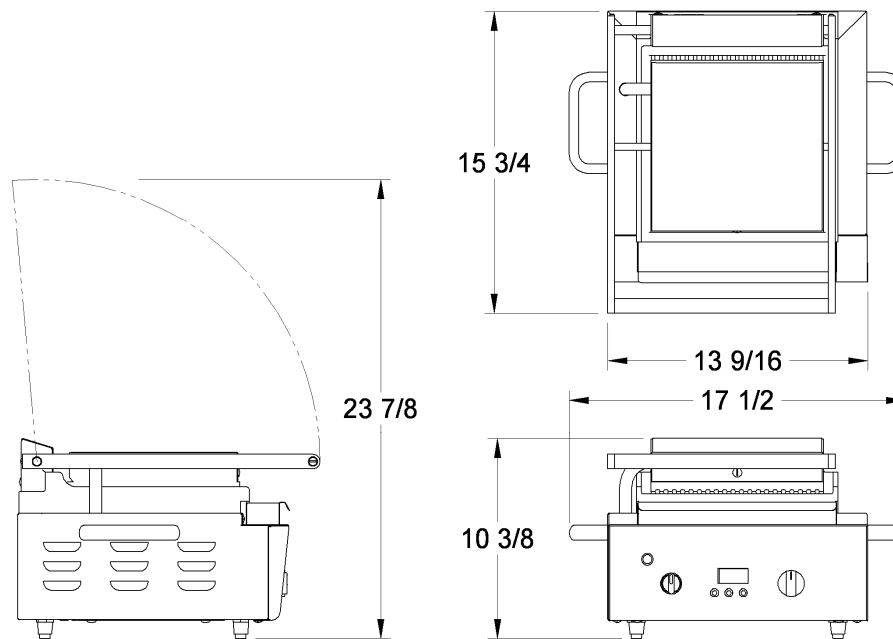



501_502

*Space Requirements, (Shown with Standard Options):
Model 502 & 502-N (All Dimensions are Approximate)*

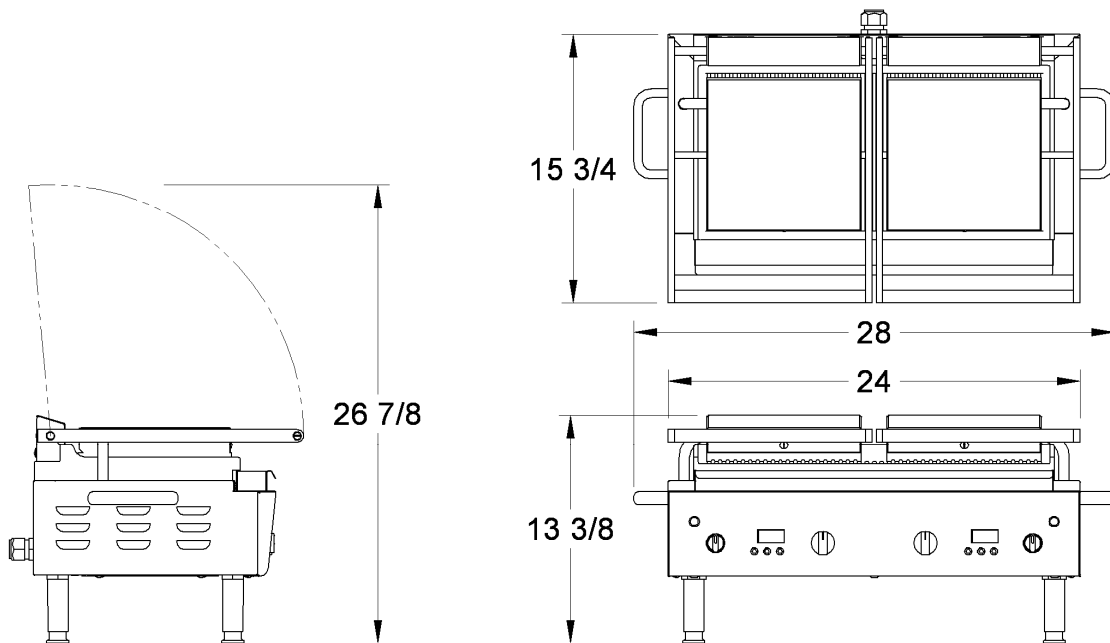

Standard Electrical Options: (Others consult factory).

WARNING

**THIS UNIT MUST BE CONNECTED TO A DEDICATED ELECTRICAL CIRCUIT
COMPATIBLE WITH THE LOAD THE GRILLE WILL PLACE ON IT.**

Model 501/501-N Single Upper Platen Panini Grille

- 1 phase, 60 hz, 115VAC, 18 Amps, 1800 Watts.
- 1 phase, 60 hz, 208/240VAC, 10 Amps, 1685/2250 Watts.
- 1 phase, 50 hz, 220VAC, 9 Amps, 1890 Watts.

Model 502/502-N Double Upper Platen Panini Grille

- 1 phase, 60 hz, 208/240VAC, 20 Amps, 3375/4500 Watts.
- 1 phase, 50 hz, 220VAC, 18 Amps, 3775 Watts



Oliver Packaging & Equipment Company
511 Sixth Street NW • Grand Rapids, MI 49504

(800) 253-3893
www.oliverquality.com

501_502

Options (All options are not available on All models):

Smooth Top and Bottom Platens
With or Without Electronic Timers
1 inch Legs (leveling)
2-1/2 inch Flanged Legs (leveling)
2-1/2 inch Suction Cupped Legs (leveling)
4 inch Flanged Legs (leveling)
4 inch Suction Cupped Legs (leveling)
Table Stops

Net Weight

Model 501 = 55 lbs. (approximate)
Model 502 = 105 lbs. (approximate)

Shipping Weight

Model 501 = 70 lbs. (approximate)
Model 502 = 120 lbs. (approximate)



501_502

INSTALLATION INSTRUCTIONS

Container Inspection

Inspect the container for visible and/or concealed damage, if the equipment or container seems to be damaged make a note on the shipping documents such as “Damaged” or “Open” and notify the freight company asking for an inspection. Remember, the receiver is responsible for filing damage claims. In such a situation you must retain all the packaging until the inspection is complete to verify the damage and thus lessen the chances that your claim will be denied.

Location Selection & Electrical Hook-up

DANGER

THIS UNIT MUST BE ELECTRICALLY GROUNDED. FAILURE TO DO SO COULD RESULT IN SERIOUS INJURY OR DEATH.

WARNING

THIS UNIT MUST BE CONNECTED TO A DEDICATED ELECTRICAL CIRCUIT COMPATIBLE WITH THE LOAD THE GRILLE WILL PLACE ON IT.

CAUTION

ANY STAND, COUNTER OR OTHER MOUNTING SURFACE MUST BE CAPABLE OF SUPPORTING THE GRILLE’S WEIGHT.

Select a location for your grille which has a substantial mounting surface, such as a countertop, table or stand, see “Caution” statement above, and which is near a dedicated electrical service compatible with the load the grille will place on it as indicated on the electrical data plate on the rear of the grille. Always conform to all local and national electrical codes.

Ventilation and Clearances

The use of a vent, hood, grease extractor and/or fire extinguishing system will be dictated and must conform to the applicable national and/or local building codes.

The following are suggested minimum clearances from combustible surfaces unless those directed by local building codes are greater.

- 1 inch from each side of the unit
- 4 inches from the back of the unit



501_502

Initial Set-up

Before the first use of the grille, use the height adjustable legs provided on each unit, to level it right to left. In addition, the rear of the unit should be set slightly higher than the front of the unit to allow the normal cooking fluids to more easily travel to the front grease tray.

Top Platen Assist Spring Adjustment

To allow adjustability in the amount of force required to raise or lower the top platen a drag block has been added to each top platen hinge pin. Using a screw driver a screw can be turned to increase or decrease the drag on the hinge pin. Increasing the drag, (turning the screw clockwise), will restrict the movement of the upper platen's handle. Rotating the screw counter clockwise will free the movement of the platen allowing it to drop from higher positions but pop up when at the lowest position. If you wish you may make the adjustments to fit your needs. The screw is accessible from the rear of the machine through the spring cover. Periodic adjustment of this screw may be necessary.

Seasoning of the Cooking Surfaces

NOTE

DURING INITIAL OPERATION OF YOUR GRILLE YOU MAY NOTICE A SMALL AMOUNT OF SMOKE COMING OFF THE GRILLING SURFACES, AND A FAINT ODOR FROM THE SMOKE. THIS IS NORMAL FOR A NEW GRILL AND WILL DISAPPEAR AFTER THE FIRST FEW HOURS OF USE.

CAUTION

COOKING SURFACES ARE HOT USE CARE WHENEVER WORKING NEAR THEM.

Before the first use of the grill the cooking surfaces must be seasoned to minimize product sticking. This can be accomplished by first wiping the excess oil from all cooking surfaces. Then turn the unit on by heating both top and bottom platens to a temperature of between 250 – 300°F for approximately 30-40 minutes. Do not be alarmed, but during the first few hours of operation the grille may smoke as oils associated with the manufacturing process are evaporated. After heating the grille for 30-40 minutes, (see above), spray all cooking surfaces with a non-salted vegetable oil such as Pam ®. Allow the unit to stand at the temperature until the cooking surfaces look dry, (about 30 minutes). Spray all surfaces a second time with Pam ® and then heat the unit to 400°F, which will take about 10 minutes, after which the unit should be turned off. Repeat the above procedure if necessary.



501_502

OPERATING INSTRUCTIONS

CAUTION

COOKING SURFACES ARE HOT USE CARE WHENEVER WORKING NEAR THEM.

Preheating

The unit should be allowed to preheat approximately 10-20 minutes before loading it with product. Failure to preheat will likely cause unsatisfactory cooking of the first load. Using the selector switch on the front of the unit, turn the switch from the “Off” position, to either the bottom only heat selection, or to the bottom and top position. Set the unit to the desired temperature, (see “Temperature Selection” below). If heating both top and bottom platens it is best to do so with the top platen lowered to contact the bottom platen. Dual units will have separate controls for each side of the grille.

When you select either the bottom or both top and bottom platen position on the selector switch the “Power On” indicator light and the optional timer, (when present), should come on, however the platen will not begin heating until a temperature above 120° F has been selected.

Temperature Selection

Each top and bottom platen is controlled by a single thermostat. Dual grilles will have a separate thermostat for each side of the unit. When the line on the knob is pointing straight up the heaters will be off. Rotating the knob clockwise will turn the heaters on starting at an approximate temperature of 120° F and if you continue to rotate the knob in the clockwise direction they will reach a maximum temperature setting of approximately 570° F. The approximate setting can be noted from the position of the line on the knob relative to the numbers printed on the front panel’s legend plate.

Setting the “Optional” Digital Timer

Grilles with the optional digital timers can be set to give an audible sound at a user specified time setting from 1 second to a maximum of 9 minutes 59 seconds. Dual units with this option will have a timer for each side of the unit.

In addition to the display, each timer will have three buttons. From the left to the right the buttons will be labeled “+”, “-”, and “Start/Stop”. The timer can be used without heating the platens by turning the selector switch to either bottom or both top and bottom platen heating, but leaving the thermostat, (temperature selection knob), set to “Off”.



501_502

Setting the “Optional” Digital Timer (Continued)

To increase the timer setting push and hold the “+” button for 5 seconds. The timer will beep after which each push and release of the button will advance the setting 1 second. If you continue to hold the button after the initial beep the timer will begin to advance rapidly. The decrease function of the timer works in the same manner except you must press and hold the “-” button.

Once set, the timer can be used by following this simple procedure. Place the product on the grill and push the “Start/Stop” button. The timer will begin counting down and will begin beeping when the set time has expired. The timer will continue to beep until you again press the “Start/Stop” button. Once the button is pressed the timer will reset itself to last time to which it was set. It will continue to repeat this setting even if the unit is turned off or unplugged until you purposely change it.

Setting the “Optional” 4 Menu Digital Timer

To enter time programming from the blank “--:--” screen, press and hold the PROGRAM button for 3 seconds. The display will now show “PROG”. To change a time on one of the four timers, press the desired timer button. The display will now change to the existing set time. Now press the “+” or “-” button to change to the desired time. To change another timer, press that particular timer button and follow the same procedure.

To exit the time programming mode, press the PROGRAM button and the timer will return to the operating mode with the blank display of “--:--”.

To cancel a timer that is on, press and hold that particular timer’s button until it resets.

To view the time remaining on a particular timer, press the SCAN button. Continue to press the SCAN button to toggle through all active timer times.



Oliver Packaging & Equipment Company
511 Sixth Street NW • Grand Rapids, MI 49504

(800) 253-3893
www.oliverquality.com

501_502

CAUTION

STOPPING THE TIMER WILL NOT STOP COOKING. THE PLATENS WILL REMAIN HEATED, YOU MUST REMOVE THE PRODUCT FROM THE GRILLE.

Operating Hints

When heating both platens of the unit during periods of disuse it is more efficient to lower the top platen or platens to better retain heat.

During longer periods of disuse it is more efficient to turn the temperature setting down to about 200° F. When the unit is again required it will recover quickly, usually within a few minutes.

If you are not going to use the grill for a longer period of time, or leave it unattended, it should be turned "OFF".



501_502

TROUBLESHOOTING

DANGER

ALWAYS DISCONNECT THE GRILLE FROM THE POWER SUPPLY BEFORE ATTEMPTING ANY TYPE OF MAINTENANCE TASK, INCLUDING TROUBLESHOOTING.

CAUTION

COOKING SURFACES ARE HOT USE CARE WHENEVER WORKING NEAR THEM. ALLOW SUFFICIENT TIME FOR COOLING BEFORE BEGINNING WORK.

NOTE

ON DUAL UNITS REMEMBER THAT EACH SIDE HAS SEPARATE CONTROLS.

The Grille is not Heating (Indicator Light Is Not On)

- The grille is not plugged in.
- The grille's selector switch is in the "Off" position. Select one of the two heat positions.
- There is no power at the outlet. (Check by plugging in another working appliance. Check to see if a circuit breaker has tripped. If the circuit breaker has not tripped and the circuit is still not working have a qualified electrician check the circuit.)
- The problem is with one or more of the following grille components: power cord, indicator light, or selector switch. (Have a qualified electrician find and repair the problem.)

The Grille is not Heating (Indicator Light Is On)

- The thermostat (temperature selection knob), is set either in the "Off" position or is set below 120° F.
- If the thermostat is properly set and the selector switch is set to top and bottom platen heating and both platens are not getting hot have a qualified electrician check the selector switch and the thermostat for proper operation.

Continued



501_502

Trouble Shooting (Continued)

The Grille is not Heating (Indicator Light Is On) (Continued)

- If the thermostat is properly set, and working, and the selector switch is set for top and bottom platen heating, and both platens are still not getting hot, have a qualified electrician check the selector switch, both heating elements as well as their connective wiring.
- If the thermostat is properly set, and working, and the selector switch is set for top and bottom platen heating, and only one of the platens is getting hot, have a qualified electrician check the selector switch, the heating element which is not getting hot as well as their connective wiring.

Product is Either Burning or Under Cooking

- The thermostat, (temperature selection knob), may be improperly set, increase or decrease the setting as required.
- Have a service technician use a temperature sensing device to compare the actual temperature of the platens with the set temperature indicated on the front control panel. Both platens should be heated with the top platen in the closed position. Please realize that the numbers on the control panel are only approximate and that the actual temperature may vary +/- 25° F.

The Top Platen Falls If not Held

- Using a screw driver, (through the access hole in the spring cover), increase the amount of drag on the top platen hinge pin. Rotating the screw in a clockwise direction will increase the drag.
- The assist spring as failed. Have a service technician replace it.

The Optional Digital Timer Does Not Turn On (The Rest of the Unit is Working)

- Have a qualified electrician check the transformer, the timer and its connective wiring.

The Optional 4 Menu Digital Time Does Not Turn On (The Rest of the Unit is Working)

- Have a qualified electrician check the timer and its connective wiring.



501_502

MAINTENANCE

DANGER

ALWAYS DISCONNECT THE GRILLE FROM THE POWER SUPPLY BEFORE ATTEMPTING ANY TYPE OF MAINTENANCE TASK,

CAUTION

COOKING SURFACES ARE HOT USE CARE WHENEVER WORKING NEAR THEM. ALLOW SUFFICIENT TIME FOR COOLING BEFORE BEGINNING MAINTENANCE.

Top Platen Assist Spring Adjustment

To allow adjustability in the amount of force required to raise or lower the top platen a drag block has been added to each top platen hinge pin. Using a screw driver, a screw can be adjusted to increase or decrease the drag on the hinge pin. Increasing the drag, (turning the screw clockwise), will restrict the movement of the top platen's handle. Rotating the screw counter clockwise will free the movement of the platen allowing it drop from higher positions but pop up when at the lowest position. If you wish you may make this adjustment to fit your needs. The screw is assessable from the rear of the machine through the spring cover. Periodic adjustment of this screw may be necessary.

Cleaning

WARNING

HOLD THE TOP PLATEN OPEN WHILE CLEANING IT TO PREVENT ACCIDENTAL CLOSURE.

As Required Cleaning:

We recommend the scraping of the top and bottom cooking surfaces, with the scraping tool provided, between each load to minimize excessive carbon buildup on the cooking surfaces. Excessive carbon buildup will decrease the cooking surface's efficiency, negatively affecting grille performance.

As necessary throughout the day empty the front grease tray. It can be hand washed in a normal dish cleaning solution or placed in a dishwasher.

Continued



501_502

Cleaning (Continued)

Daily Cleaning

DANGER

ALWAYS DISCONNECT THE GRILLE FROM THE POWER SUPPLY BEFORE ATTEMPTING ANY TYPE OF MAINTENANCE TASK,

DANGER

DO NOT WASH DOWN OR IMMERSE THE GRILLE IN WATER OR OTHER LIQUIDS

CAUTION

DO NOT USE ICE OR COLD WATER TO CLEAN HOT CAST IRON COOKING SURFACES. RAPID TEMPERATURE CHANGES MAY CRACK THEM.

Disconnect the unit from the power supply and lock it out before cleaning. Allow the unit to cool to a temperature of approximately 100° F before cleaning to prevent accidental burns.

Most surfaces are either stainless steel or cast iron, the stainless steel surfaces can be cleaned with a warm damp cloth and a mild detergent. Polish with a dry soft cloth. Frequent cleanings of the stainless surfaces will keep them from yellowing due to baked on grease.

Daily, after letting the cooking surfaces cool, scrap them thoroughly and wipe them down with a clean cloth removing as much grease and foreign mater as possible.

Major Cleanings

Should it become necessary to remove a heavy carbon buildup on the cooking surfaces, through a thorough scraping or other radical cleaning, it may become necessary to re-season the grill. See "Seasoning of the Cooking Surfaces" in the "Installation Instruction" portion of this manual.



501_502

RECOMMENDED SPARE PARTS

<u>PART NUMBER</u>	<u>PART DESCRIPTION</u>	<u>NO. REQ'D</u>
0501-0035	Scrapper-Panini	1
5501-7940	Insulation-Heater	2
5501-7945	Insulation-Lower (Models 502 & 502-N)	1
5501-7946	Insulation-Lower (Models 501 & 501-N)	1

The following components comprise a single Selector Switch

5708-7935	Operator-Selector Switch	1
5708-7928	Contact-NO	3
5708-7940	Block-Mounting Adaptor	1
5708-7945	Ring-Anti Rotation	1

5730-2658	Upper Tubular Heater 1000W, 208/220/240VAC	1
5730-2659	Lower Tubular Heater 1250W, 208/220/240VAC	1
5730-2660	Upper Tubular Heater 800W, 110/115V	1
5730-2661	Lower Tubular Heater 1000W, 110/115V	1
5759-2002	Thermostat	1
7030-0028	Spring-Torsion	1

Optional Parts:

5759-5040	Timer-Digital	1
5759-5042	Timer-Digital 4 Menu	1
5760-3008	Transformer 115/230	1

For Service Parts Call Oliver Products @ 800-253-3893

Rev. 8/16/06



MODEL 501 & 501-N PANINI GRILLES

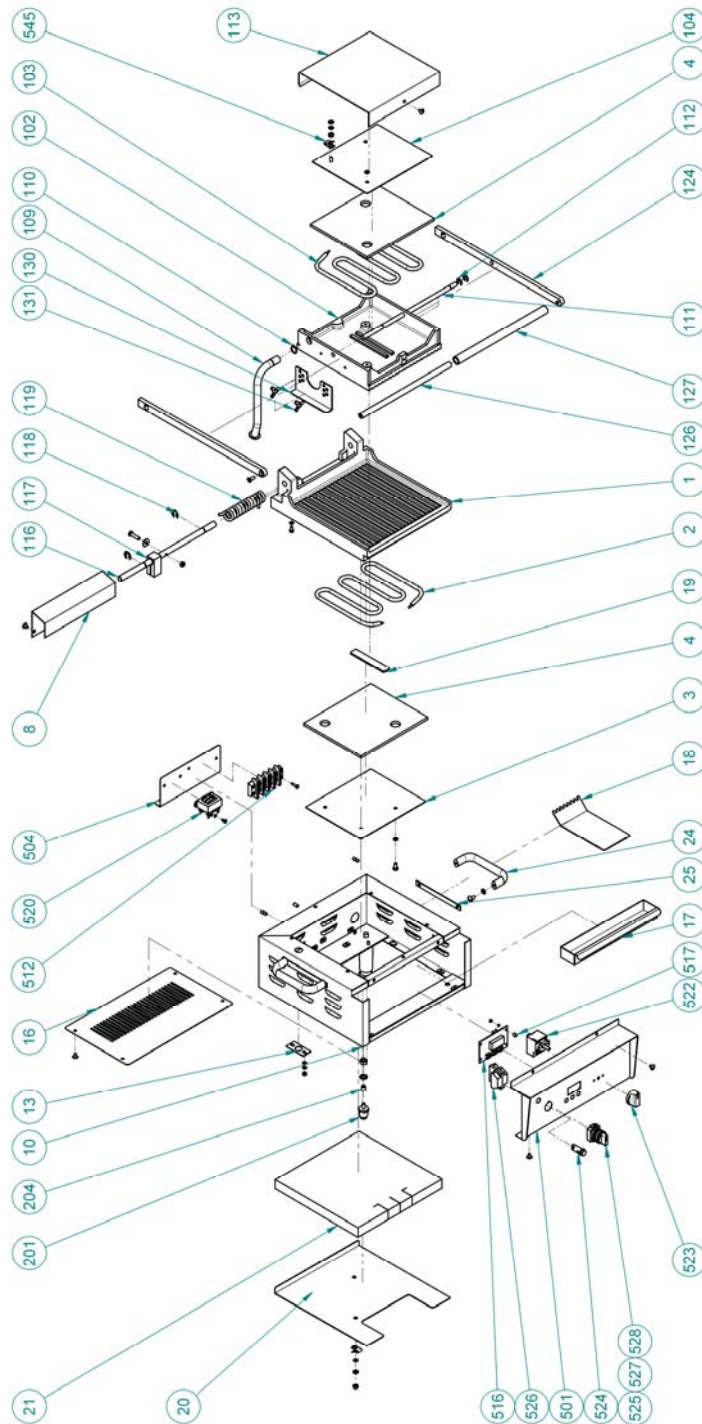

REV. 8/2/07



MODEL 501 & 501-N PANINI GRILLE PARTS LIST

<u>ITEM NO</u>	<u>PART DESCRIPTION</u>	<u>PART NUMBE</u>
001	Platen-Single Lower Ribbed	0501-0002
001	Platen-Single Lower Smooth (Not Shown)	0501-0002-001
002	Heater-Tubular 1250W 208/220/240VAC	5730-2659
002	Heater-Tubular 1000W 115VAC	5730-2661
003	Plate-Lower Heater Holddown	0501-0012-001
004	Insulation	5501-7940
008	Cover-LH Spring	0501-0013-0012
010	Base-Small Single	0501-0001
013	Guide-Tube	0501-0014
016	Cover-Base Bottom	0501-0033
017	Tray-Grease	0501-0034
018	Scraper-Panini	0501-0035
019	Spacer-Bulb & Capillary Tube	0501-0037
020	Cover-Insulation	0501-0039
021	Insulation-Lower	5501-7946
024	Handle-Pull	5908-5135
025	Plate-Backing	0501-0038
102	Platen-LH Upper 9 X 9 Ribbed	0501-0003-0002
102	Platen-LH Upper 9 X 9 Smooth (Not Shown)	0501-0003-0012
103	Heater-Tubular 1000W 208/220/240VAC	5730-2658
103	Heater-Tubular 800W 115VAC	5730-2660
104	Plate-Heater Holddown	0501-0012
109	Tube-LH Conduit	0501-0004-0012
110	Ring-Retaining	5840-1128
111	Rod-Platen Pivot	0501-0005
112	Ring-E Clip 3/8"	5840-1275
113	Cover-Upper 9 X 9 Platen	0501-0006
116	Rod-LH Hinge	0501-0007-0002
117	Block-Drag	0501-0008
118	Ring-E Clip 1/2"	5840-1280
119	Spring-Torsion	7030-0028
124	Arm-Handle	0501-0009
126	Rod-Handle	0501-0010
127	Handle-Plastic	0501-0011
130	Stop-Top Platen	0501-0042
131	Screw-Wing M6 x 10	8841-9756

REV. 8/2/07

FOR SERVICE PARTS CALL OLIVER PRODUCTS @ 800-253-3893

Continued



MODEL 501 & 501-N PANINI GRILLE PARTS LIST (Continued)

ITEM NO	PART DESCRIPTION	PART NUMBER
201	Leg-1" Leveling	5912-0532
201	Leg-2-1/2" Flanged Foot	5912-0534
201	Leg-2-1/2" Suction Cupped	5912-0533
201	Leg-4" Flanged Foot	5912-0530
201	Leg-4" Suction Cupped	5912-0531
204	Adapter-Thread (1" Legs)	5800-3605
501	Panel-Front W/Timer	0501-0016-1
501	Panel-Front W/O Timer	0501-0016-101
504	Plate-Electrical Mounting	0501-0015
512	Block-Terminal	5770-7470
516	Timer-Digital (Optional)	5759-5040
517	Stand-Off (Optional Timers)	0501-0017
520	Transformer- 115/230 (Optional Timers)	5760-3008
522	Thermostat	5759-2002
523	Knob-Thermostat	5759-2050
524	Light-Pilot 208/220/230V	5709-0012
524	Light-Pilot 115V	5709-0021
525	Operator-Selector Switch	5708-7935
526	Contact-NO	5708-7928
527	Block-Mounting	5708-7940
528	Ring-Anti Rotation	5708-7945
545	Clip-3/16 Dia.	5106-8140

Parts Not Shown on Drawing

505	Cord-Power 1 Phase 115/208/220/230V	0501-0036
506	Bushing-Strain Relief 1 Ph. 115/208/220/230	5765-1125
507	Cap-Plug 15 Amp, 1 Phase 208/230V	5765-2031
507	Cap-Plug 20 Amp, 1 Phase 115V	5765-2023
543	Sleeve-Upper Heater Wires	0501-0032
549	Sleeve-Capillary Tube	0501-0040

FOR SERVICE PARTS CALL OLIVER PRODUCTS @ 800-253-3893



501_502

MODEL 502 & 502-N PANINI GRILLES

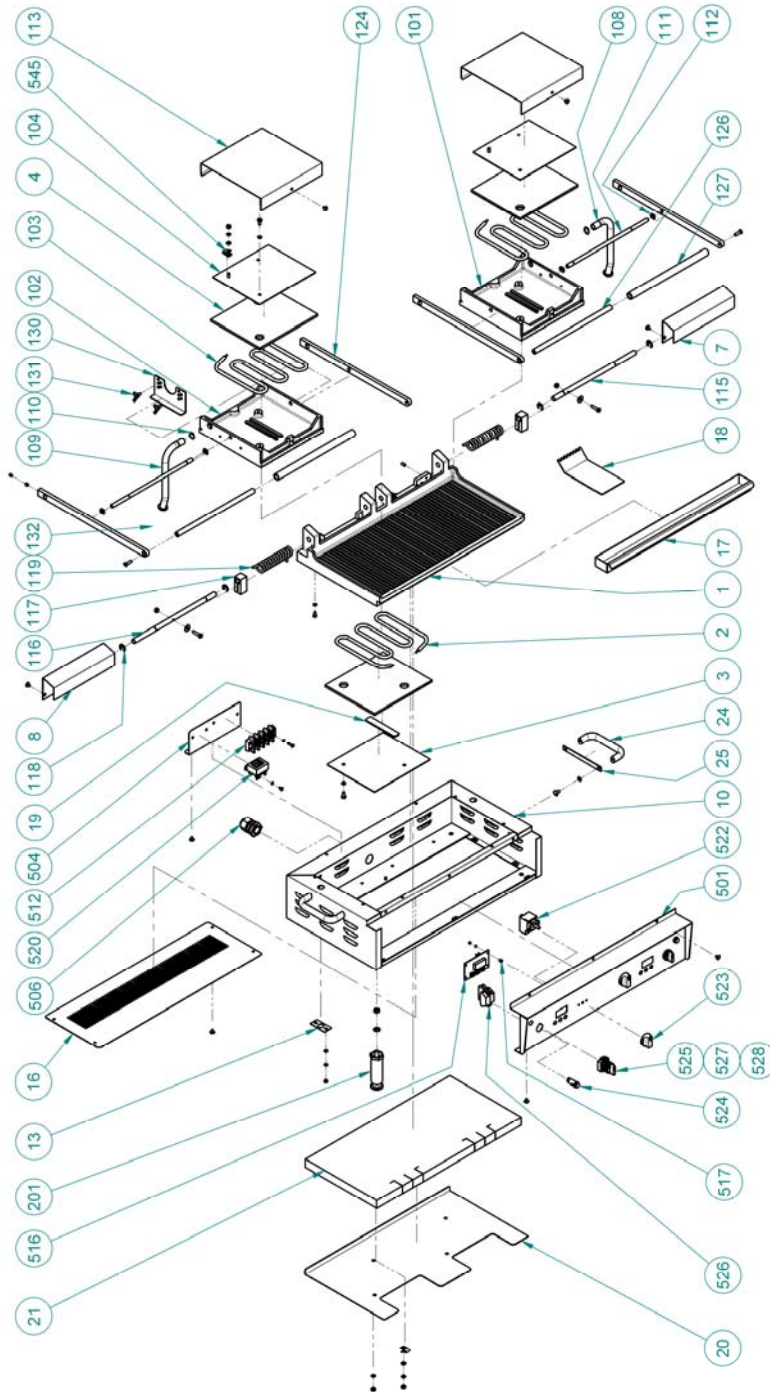

REV. 8/2/07



501_502

MODEL 502 & 502-N PANINI GRILLE PARTS LIST

ITEM NO	PART DESCRIPTION	PART NUMBER
001	Platen-Double Lower Ribbed	0502-0002
001	Platen-Double Lower Smooth (Not Shown)	0502-0002-001
002	Heater-Tubular 1250W 208/220/240VAC	5730-2659
003	Plate-Lower Heater Holddown	0501-0012-001
004	Insulation-Heater	5501-7940
007	Cover-RH Spring	0501-0013-0011
008	Cover-LH Spring	0501-0013-0012
010	Base-Small Double	0502-0001-1
013	Guide-Tube	0501-0014
016	Cover-Base Bottom	0502-0003-1
017	Tray-Grease	0502-0004
018	Scraper-Panini	0501-0035
019	Spacer-Bulb & Capillary Tube	0501-0037
020	Cover-Insulation	0502-0008
021	Insulation-Lower (502)	5501-7945
024	Handel-Pull	5908-5135
025	Plate-Backing	0501-0038
101	Platen-RH Upper 9 X 9 Ribbed	0501-0003-0001
101	Platen-RH Upper 9 X 9 Smooth (Not Shown)	0501-0003-0011
102	Platen-LH Upper 9 X 9 Ribbed	0501-0003-0002
102	Platen-LH Upper 9 X 9 Smooth (Not Shown)	0501-0003-0012
103	Heater-Tubular 1000W 208/220/240VAC	5730-2658
104	Plate-Upper Heater Holddown	0501-0012
108	Tube-RH Conduit	0501-0004-0011
109	Tube-LH Conduit	0501-0004-0012
110	Ring-Retaining	5840-1128
111	Rod-Platen Pivot	0501-0005
112	Ring-E Clip 3/8"	5840-1275
113	Cover-Upper 9 X 9 Platen	0501-0006
115	Rod-RH Hinge	0501-0007-0001
116	Rod-LH Hinge	0501-0007-0002
117	Block-Drag	0501-0008
118	Ring-E Clip 1/2"	5840-1280
119	Spring-Torsion	7030-0028
124	Arm-Handle	0501-0009
126	Rod-Handle	0501-0010
127	Handle-Plastic	0501-0011
130	Stop-Top Platen	0501-0042
131	Screw-Wing M6 x 10	8841-9756

FOR SERVICE PARTS CALL OLIVER PRODUCTS @ 800-253-3893
REV. 8/2/07

Continued



501_502

MODEL 502 & 502-N PANINI GRILLE PARTS LIST (Continued)

ITEM NO	PART DESCRIPTION	PART NUMBER
201	Leg-1" Leveling (Optional Model 502 only)	5912-0532
201	Leg-2-1/2" Flanged Foot (Opt. 502 only)	5912-0534
201	Leg-2-1/2" Suction Cupped (Opt. 502 only)	5912-0533
201	Leg-4" Flanged Foot	5912-0530
201	Leg-4" Suction Cupped	5912-0531
501	Panel-Front W/Timers	0502-0005-1
501	Panel-Front W/O Timers	0502-0005-101
501	Panel-Front Angled W/4 Menu Timer	0502-0005-105
504	Plate-Electrical Mounting	0501-0015
506	Bushing-Strain Relief 1 Ph. 208/220/230	5765-1125
512	Block-Terminal	5770-7470
516	Timer-Digital (Optional)	5759-5040
516	Timer-Digital 4 Menu (Optional)	5759-5042
517	Stand-Off (Optional Timers)	0501-0017
517	Stand-Off (Optional 4 Menu Timer)	0502-0009
520	Transformer- 115/230 (Optional Timers)	5760-3008
522	Thermostat	5759-2002
523	Knob-Thermostat	5759-2050
524	Light-Pilot	5709-0012
525	Operator-Selector Switch	5708-7935
526	Contact-NO	5708-7928
527	Block-Mounting	5708-7940
528	Ring-Anti Rotation	5708-7945
545	Clip-3/16 Diameter	5106-8140

Parts Not Shown on Drawing

505	Cord-Power 1 Phase 208/220/230V	0502-0007
507	Cap-Plug 30 Amp, 1 Phase 208/230V	5765-2021
543	Sleeve-Upper Heater Wires	0501-0032
549	Sleeve-Capillary Tube	0501-0040
550	Spacer-Aluminum (Optional 4 Menu Timer)	5845-6559

FOR SERVICE PARTS CALL OLIVER PRODUCTS @ 800-253-3893
Rev. 8/16/06



MODEL 501 & 501-N WIRING DIAGRAM 1-50/60-208/220/240 WITH TIMER

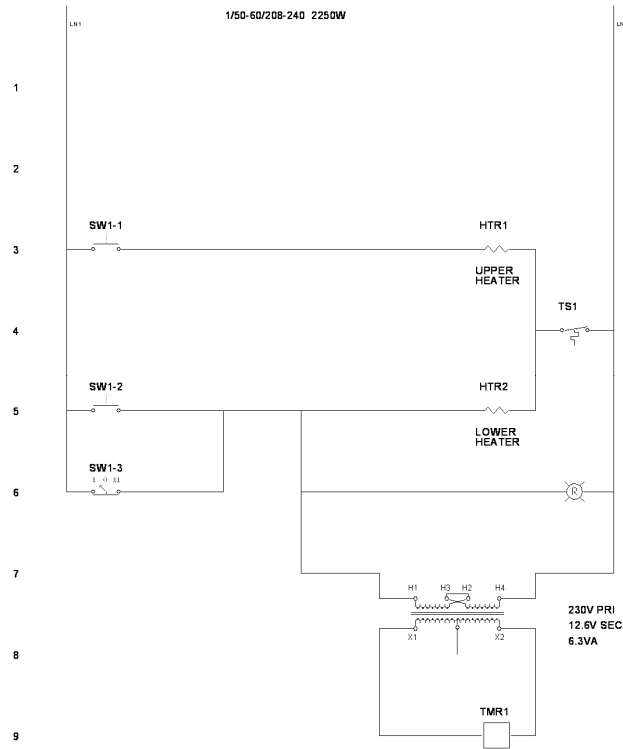

MODEL 501 & 501-N WIRING DIAGRAM 1-50/60-208/220/240 W/O TIMER

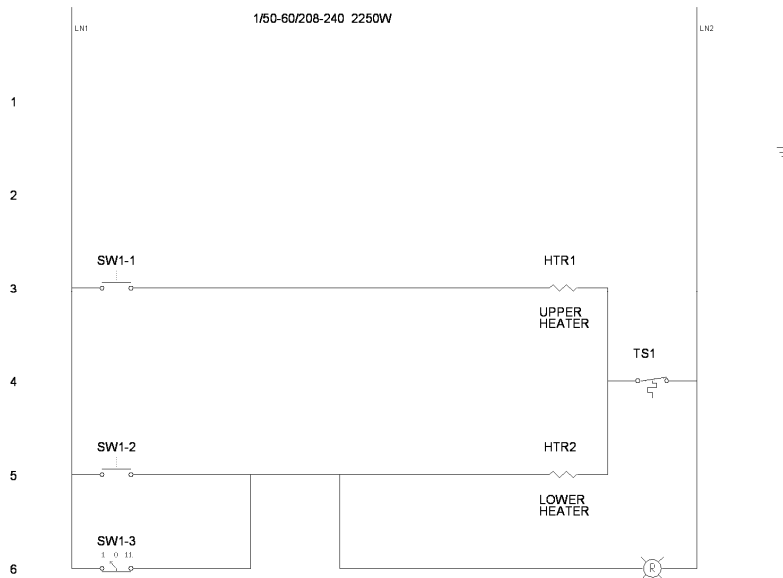



MODEL 501 & 501-N WIRING DIAGRAM 1-50/60-110/115 WITH TIMER

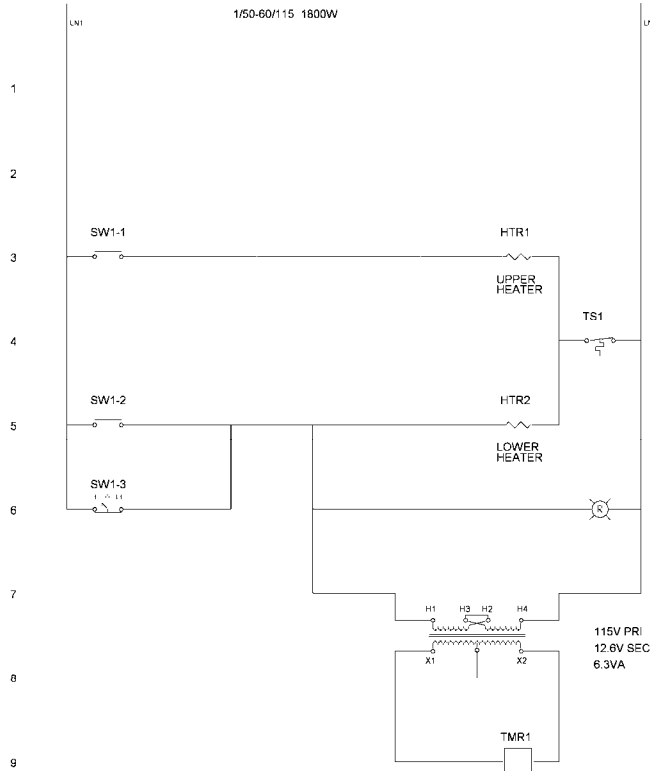

MODEL 501 & 501-N WIRING DIAGRAM 1-50/60-110/115 W/O TIMER

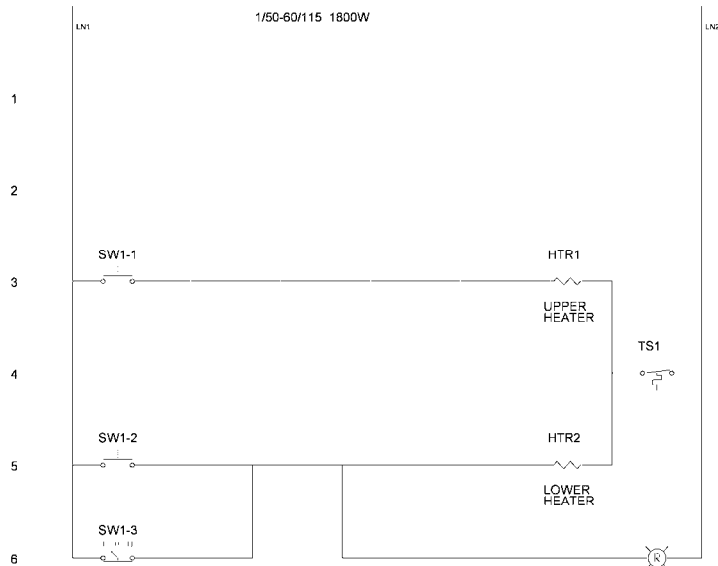



501_502

MODEL 502 & 502-N
WIRING DIAGRAM 1-50/60-208/240 WITH DIGITAL TIMERS

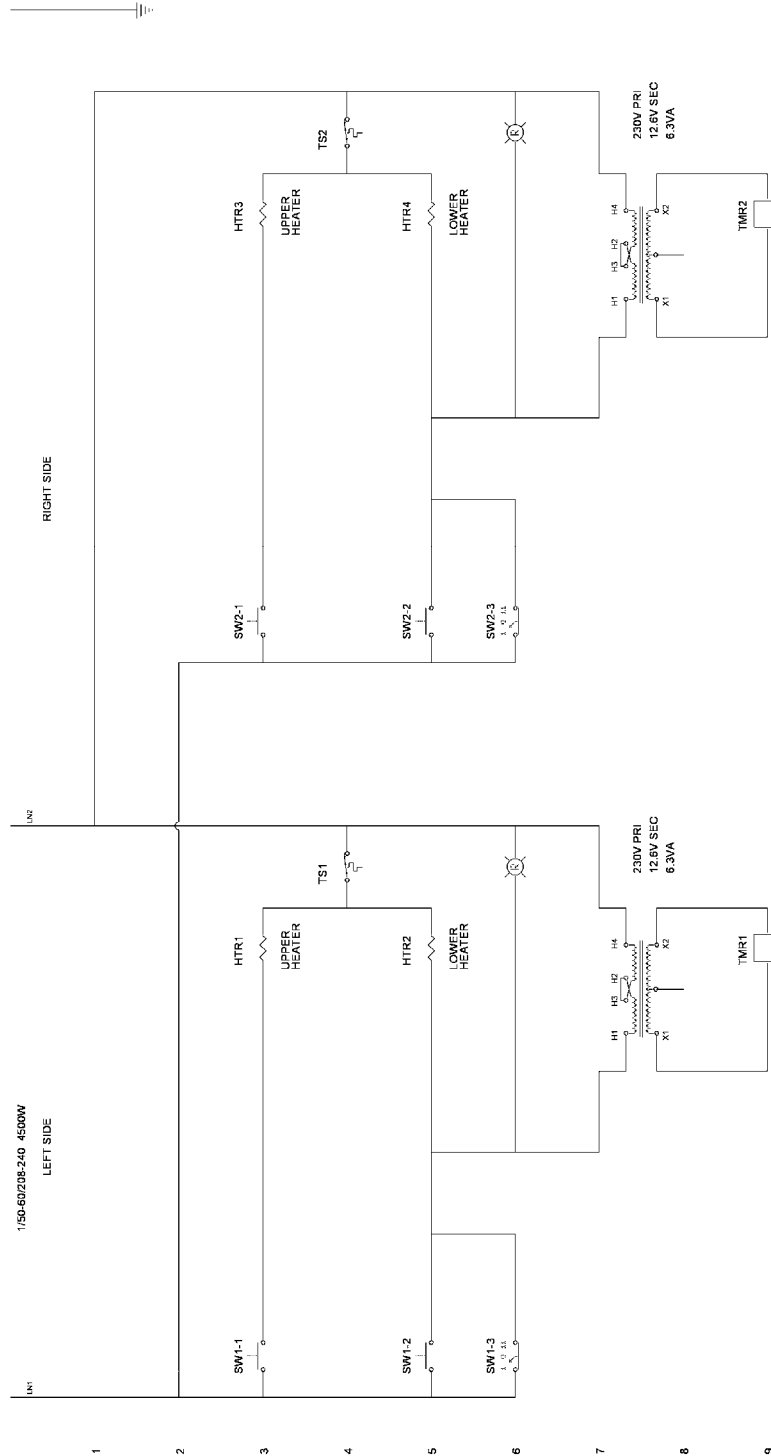



501_502

MODEL 502 & 502-N
WIRING DIAGRAM 1-50/60-208/220/240 4500W WITH 4 MENU DIGITAL TIMER

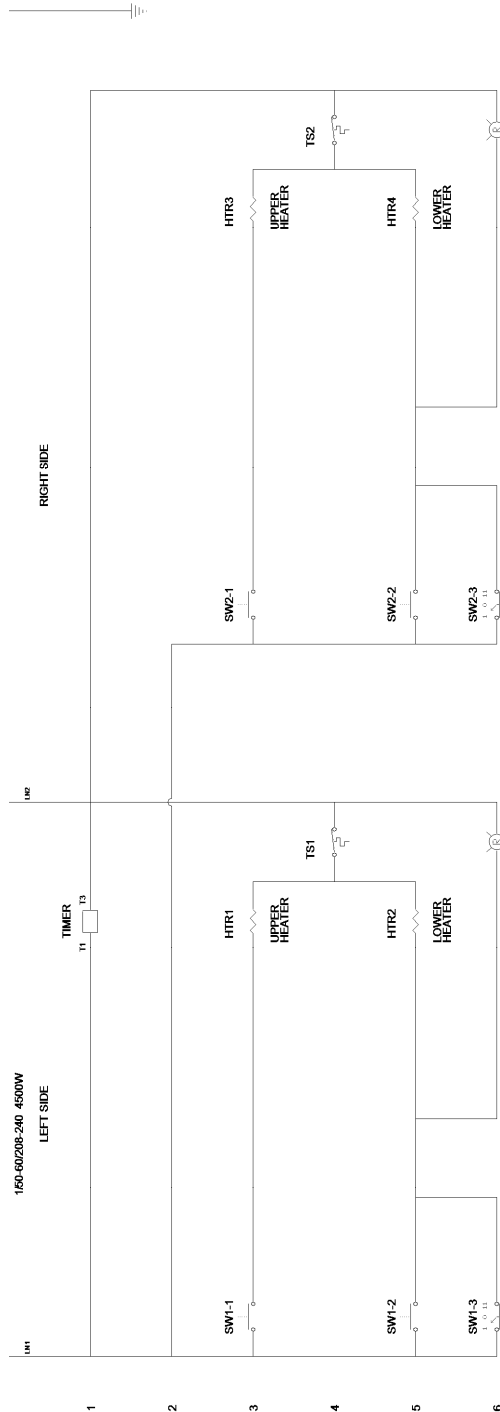

(SAME FOR SW2)

Multiposition Switch Contact Configuration		
SELECTOR	3 POSITION	
3 - NO CONTACTS SWITCH POSITION		
DESCRIPTION	RING CLAMP POS1	1 2 3
SW1-1	3	X
SW1-2	5	X
SW1-3	5	X

THEORY OF OPERATION:

1. EACH SIDE CONTROLLED SEPERATELY WITH COMMON POWER SUPPLY CORD.
2. EACH SIDE CAN BE ON OR OFF WITHOUT OTHER SIDE.
3. EACH SIDE HAS A POWER INDICATOR LIGHT.
4. EACH SIDE CAN HAVE "TOP" HEATER ON, "OFF", OR "TOP AND BOTTOM" HEATERS ON.
5. TIMER IS "ON" ANYTIME POWER CORD IS PLUGGED IN.

Rev. 8/16/06



501_502

MODEL 502 & 502-N
WIRING DIAGRAM 1-50/60-208/220/240 WITHOUT TIMERS

