



Grand Rapids, Michigan, U.S.A. 49504-5298

USER'S OPERATING AND INSTRUCTION MANUAL

MODEL 1508-M

MANUAL TRAY LIDDER



INDEX

SAFETY INSTRUCTIONS.....	1508S20015
SET UP.....	1508S20016
OPERATING PROCEDURE.....	1508S20017
ADJUSTMENTS.....	1508S20018
TECHNICAL SPECIFICATIONS.....	1508S20019
CLEANING.....	1508S20020
TROUBLE SHOOTING.....	1508S20021
ASSEMBLIES	
HEATER PLATEN ASSEMBLY	1508S20022
PLATEN PUSHER ASSEMBLY	1508S20023
FINAL ASSEMBLY.....	1508S20024
MACHINE EXCHANGE PROGRAM.....	GEN 050819
WARRANTY.....	GEN 040225
WARRANTY PROCEDURE.....	GEN 040226
RETURNED PARTS POLICY.....	GEN 040227



1508M MANUAL LIDDER

SAFETY

Various safety devices and methods of guarding have been provided on this machine. It is essential, however, that machine operators and maintenance personnel observe the following safety precautions. Improper installation or operation of this equipment may cause injury to personnel or damage to equipment.

- Before operating the *Manual Lidder* read through this manual. Never allow an untrained person to operate this machine.

CAUTION

- **CAUTION HOT:** The heater cover and upper platen are very **HOT!** Caution must be used to protect yourself and others.

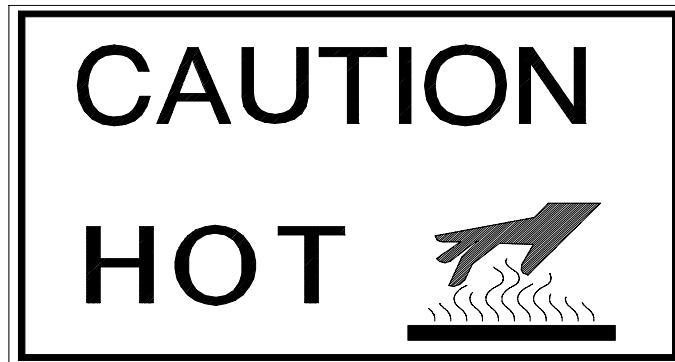

- In addition to these general safety instructions, follow the specific instructions given throughout this manual.



1508M MANUAL LIDDER

SET UP

1. Unpack and carefully remove the *Manual Lidder*. Check for completeness of your order and that none of the items have been damaged during shipment.
2. Screw the four rubber feet in to place on the bottom of the machine.
3. Place the *Manual Lidder* in a suitable location that provides adequate working space. The location must be sturdy, level, and capable of holding 50 lbs. per machine.
4. Plug the power cord into a grounded electrical outlet. The *Manual Lidder* requires single phase 110 VAC, 60 Hertz with 10 ampere (minimum) circuit breaker protection.
5. Install the tray carrier:

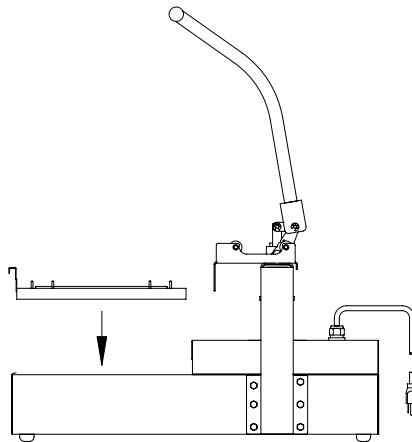

6. Load lid dispenser:

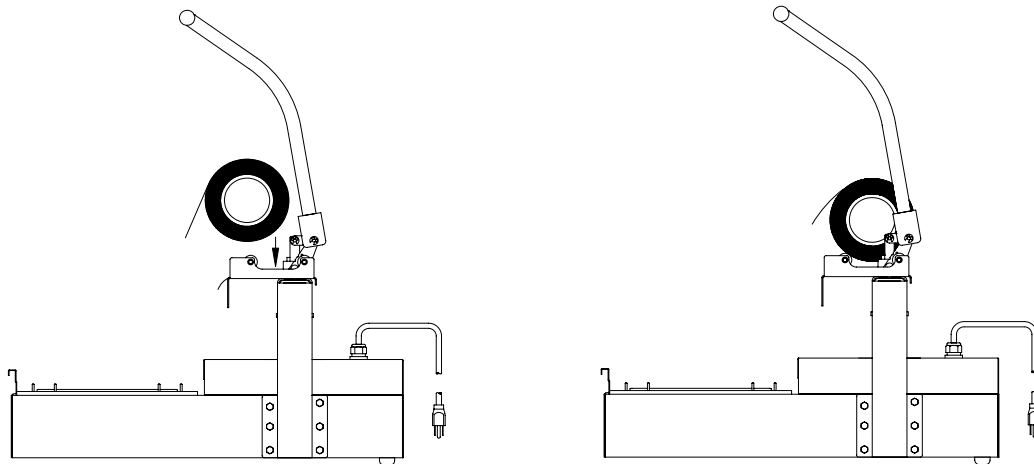



1508M MANUAL LIDDER

OPERATING PROCEDURE

1. To turn the machine on plug in the power cord. **Wait 40 minutes** to allow the heated upper platen to reach temperature.
2. Place a tray in the tray carrier.
3. Position a single lid on the tray. Use the retractable pins on the tray carrier to center the lids over the tray. **Be sure the adhesive side of the lid is down.**

NOTE

- The adhesive side of the lid can be determined by pinching a fold and rubbing the lid material against itself. Test both sides of the lid. The rough or tacky side of the lid will be the adhesive side.
4. Push the tray carrier into the *Manual Lidder* until it stops.

NOTE

- Actuating machine with no tray or lid in place may cause the tray carrier to stick closed.
5. Rotate the handle down into the locked position. (Do not force handle)
 6. Wait 1 second.
 7. Rotate the handle up to the start position.
 8. Pull the tray carrier out of the manual lidder.
 9. Remove the lidded tray by pushing up on the bottom of the tray and lifting from tray carrier.



1508M MANUAL LIDDER

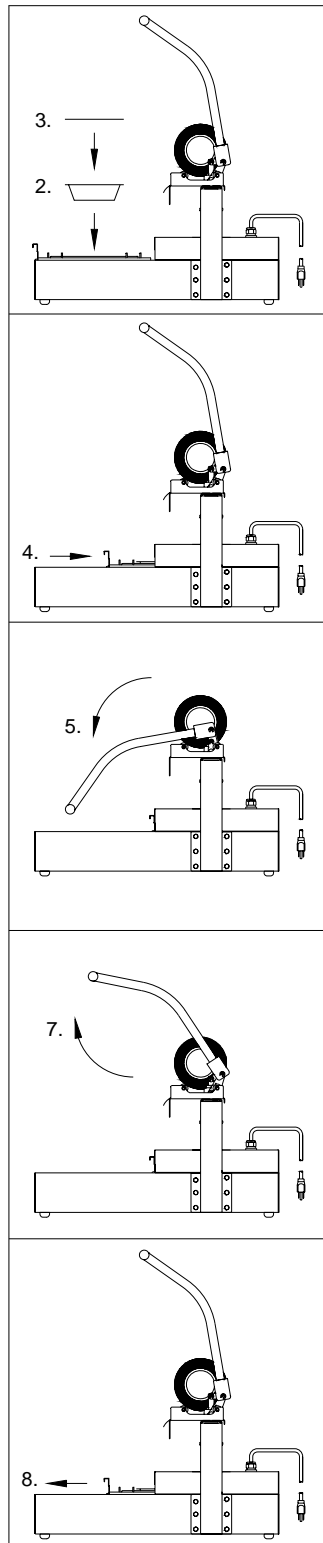



1508M MANUAL LIDDER

TECHNICAL SPECIFICATIONS

Tray Capacities:

8" (203mm) by 9.75" (248mm) maximum top-outside-dimension tray.

Temperature Range:

50°F (10°C) to 300°F (149°C)

Machine Dimensions:

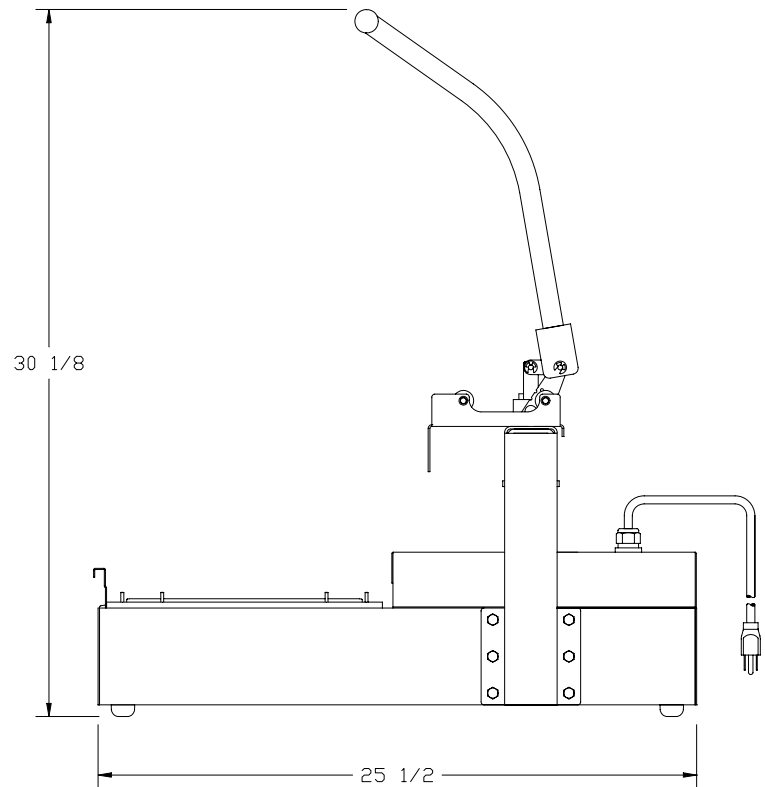
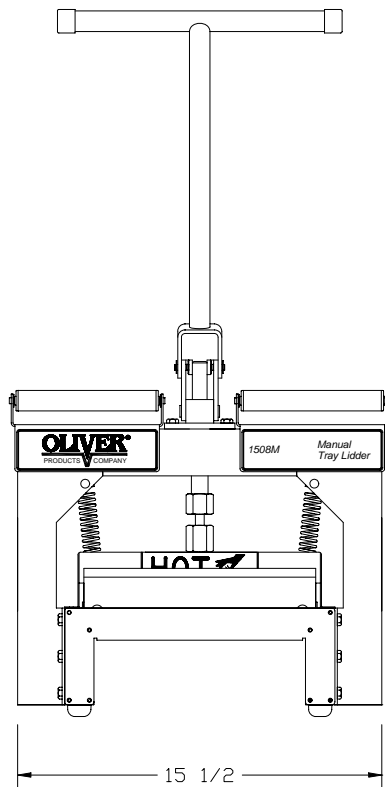

Weight:

55 lbs. (22.7 kg)

Electrical:

115 VAC, 8 Amps, Single Phase, 50/60 Hz **OR**
230 VAC, 4 Amps, Single Phase, 50/60 Hz



1508M MANUAL LIDDER

CLEANING

- If the machine has been operating, allow the unit to cool before cleaning.

CAUTION

- **CAUTION HOT:** The heater cover and upper platen are very **HOT!** Caution must be used to protect yourself and others.
- Make sure the unit has been unplugged from power before cleaning.
- Clean the *Manual Lidder* with a mild cleaner and a damp cloth.
- To clean or access the heated upper platen: remove the tray carrier and lidding material and tip machine back (see setup).

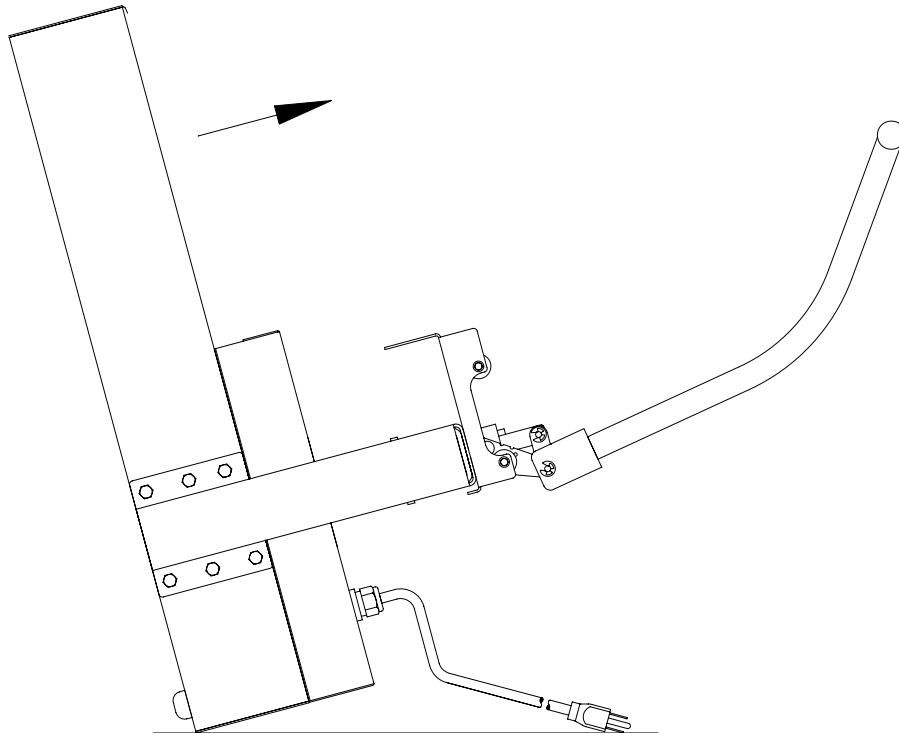

CAUTION

- **MAKE SURE UNIT IS SECURE AND WILL NOT TIP OVER**
- Use a copper scouring pad to clean heated upper platen. Allow platen to cool before attempting to clean.



1508M MANUAL LIDDER

TROUBLE SHOOTING

SYMPTOM	CORRECTIVE ACTION
Heater will not power up	<ol style="list-style-type: none">1. Verify that the power cord is plugged in2. Press Reset on the circuit breaker
Lid folding, shifting or sliding off machine	<ol style="list-style-type: none">1. Verify that the adhesive side of the lid is down2. Verify that the trays are not over filled3. Clean the heated upper platen
Poor seal quality ↵ Allow seal to cool before checking quality	<ol style="list-style-type: none">1. Verify the temperature setting (adjustments)2. Clean the upper platen (cleaning)

Oliver Products Company 24 hr emergency service (800) 554-5603



1508M MANUAL LIDDER

HEATER PLATEN ASSEMBLY

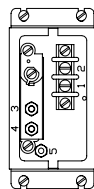
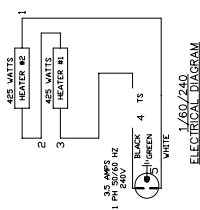
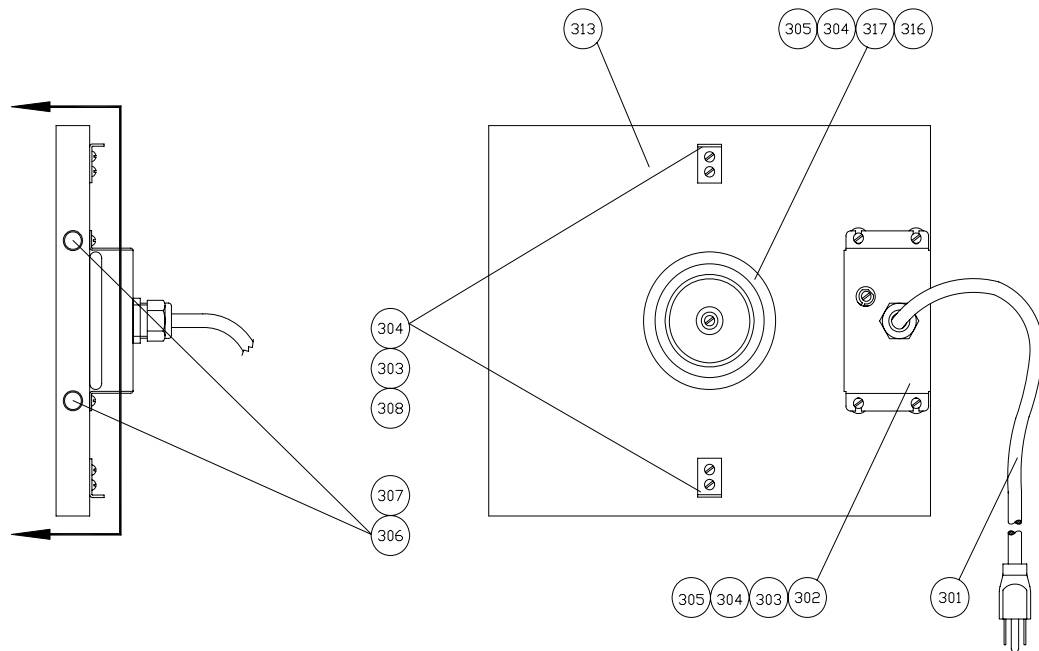

305

304

303

312

311

310

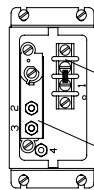
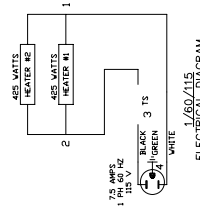

305

304

303

309

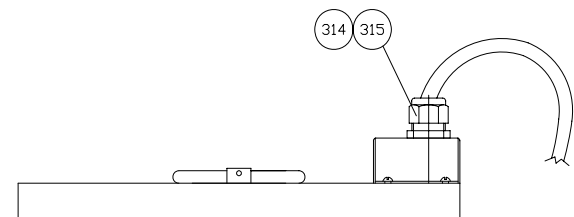

ITEM	PART NUMBER	DESCRIPTION	QUAN.	DWG
301	1508-0021	CORD-POWER	1	C
302	1508-0013	BOX-ELECTRICAL	1	C
303	5843-5210	SCRW-RD HD 6-32x1/4	12	PUR
304	5851-9353	WSHR-#6 MD SPRNG LCK	14	PUR
305	5851-9300	WSHR-#6 FLAT 18-8	11	PUR
306	5730-1574	HTR-CRTRDGE 1/2" x 8"	2	PUR
307	5768-1289	TERM-#6 RING 18-22 GA	1	PUR
308	1508-0009	SPRING CLIP	2	C
309	5757-9733	THERMOSWTCR-SURF MNT	1	PUR
310	5770-7462	BLK-TERM 2 POSITION	1	PUR
311	5770-7461	JMPR-TERMINAL BLOCK	1	PUR
312	5843-5212	SCRW-RD HD 6-32x1/2	2	PUR
313	1508-0003-1	UPPR HTR PLATTEN LRG.	1	D
314	5770-4817	RLF-STRN STR 1/2"	1	PUR
315	5766-7750	NUT-LCK APPLETON#BL50	1	PUR
316	6516-0070	INSULATOR-PUSHER SLCN	1	C
317	5843-5211	SCRW-RD HD 6-32X3/8	1	C

REV. 1/16/00



1508M MANUAL LIDDER

PLATEN PUSHER ASSEMBLY

ITEM	PART NUMBER	DESCRIPTION	QUAN.	DWG
201	1508-0001-1011	RAIL-R. H. MANUAL UNIT	1	C
202	1508-0024-1	RDD-SLIDE 25 5/16' LG.	4	C
203	7024-4104	SPRING-TENS. 3/4x2 1/2	2	PUR
204	1508-0040	PUSHER UPPR HTR PLATEN	1	C
205	5843-1002	SCREW-HEX HD 1/4-20	25	PUR
206	5851-9304	WASHER-1/4' FLAT STST	1	PUR
207	5842-8994	SCREW-SHOULDER 1/4x3/4	2	PUR
208	1508-0041	SHAFT ADJUSTMENT	1	C
209	1508-0042	NUT-HEX LOCK	1	C
210	1508-0039	PUSHER LOWR HTR PLATEN	1	C
211	7011-2102	SPRING-COMPRESSION	32	PUR
212	1508-0001-1002	BASE-LEFT HAND	1	C

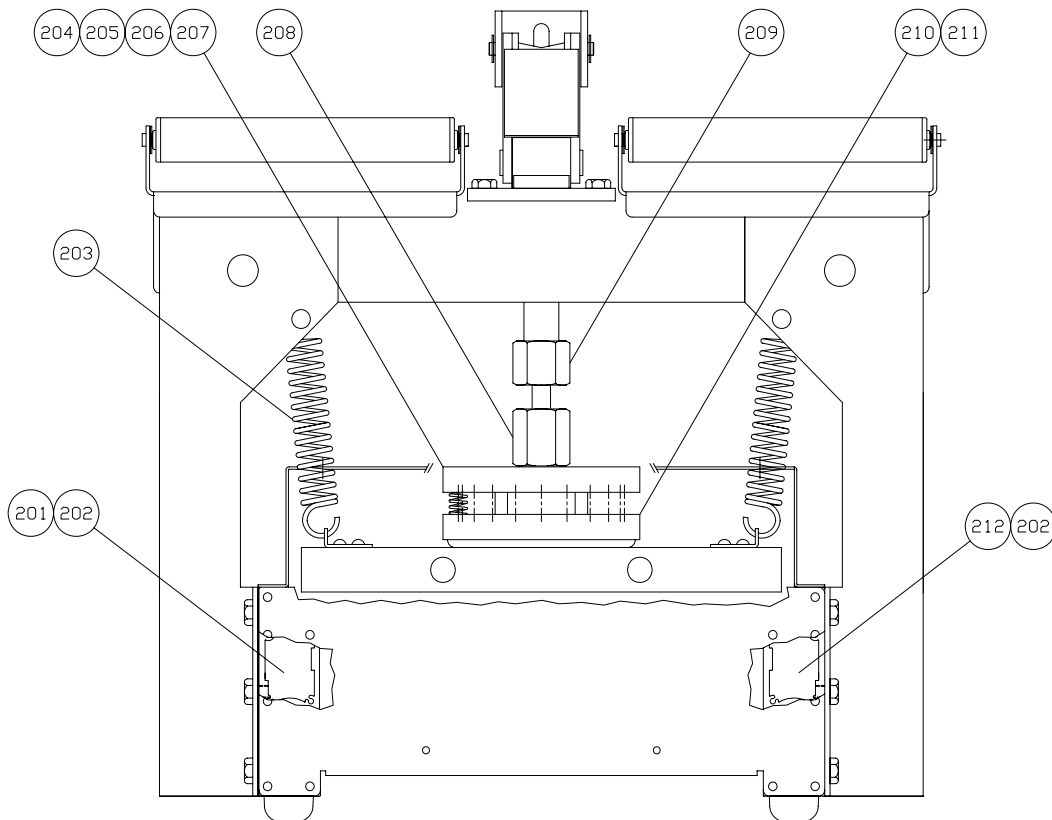



1508M MANUAL LIDDER

FINAL ASSEMBLY

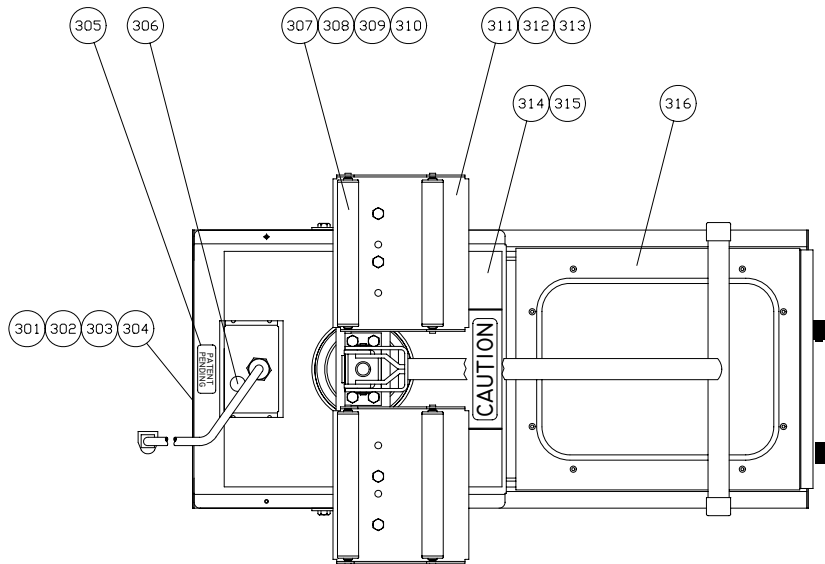

ITEM	PART NUMBER	DESCRIPTION	QUAN.	DWG
301	6400-5006	NMPLT-ETL USA/CAN LBL	1	PUR
302	6401-5066	NMPLT-OLVR 24HR EMER	1	PUR
303	6401-5048	NMPLT-OLVR W/ELEC	1	PUR
304	5840-3501	POP RIVET 1/8 STST	4	PUR
305	6401-6002	NMPLT-PAT. PEND. PRNT	1	PUR
306	5765-4732	PLUG SNAP BTN. 1/2"	1	PUR
307	1508-0044	ROD FILM DISPENSER	4	C
308	4639-1414-1111	TUBE-ALUM. 7/8x5 7/8	4	PUR
309	5252-3002	BRNG-ROLL END BSTN	8	PUR
310	5840-1273	RING-RET'G TRUARC	12	PUR
311	1508-0043	FRAME-FILM DISPENSER	2	C
312	5843-1002	SCREW-HEX HD 1/4-20	25	PUR
313	5851-9357	WSHR-LCK 1/4 SS SPRNG	25	PUR
314	1508-0014-1	COVER MAIN SHIELD	1	D
315	5843-5210	SCRW-RD HD 6-32x1/4	33	PUR
316	1508-XXXX	TRAY HOLDER	1	C
317	1508-0002	LEG-ARCH	2	C
318	1508-0019	PIN-SPRING SUPPORT	2	C
319	1508-0045	BRACKET TUBE CLAMP	1	C
320	1508-0046	HANDLE	1	C
321	1508-0047	PIN CLAMP BRACKET	1	C
322	1508-0048	PIN CLAMP PUSHER ROD	1	C
323	1508-0049	CLAMP PRESSURE	1	C
324	5105-5250	CAP PROTECTIVE VINYL	2	PUR
325	6402-3009	NMPLT-WARNING W/PICT	2	PUR
326	1508-0006-1	COVER - REAR	1	C
327	5902-0035	BUMPER-RUBBER W/SCRW	4	PUR
328	1508-0005-1	COVER - FRNT	1	C
329	1508-0050	DECAL-OLIVER 1508M	1	C
330	6400-3017	SIGN-CAUT'N HDT W/HND	1	PUR

