



Grand Rapids, Michigan, U.S.A. 49504-5298

USER'S OPERATING AND INSTRUCTION MANUAL

MODEL 1208, 1208-N, & 1208-NLG

HEAT SEALER

MFG DATE: _____

MODEL NUMBER: _____

SERIAL NUMBER: _____

1208S20000CV2



INDEX

Description and Specifications----- pg. 1-2

Description and Specifications Continued----- pg. 1-3

Safety----- pg. 1-4

Machine Components and Set Up----- pg. 1-5

Set up Continued----- pg. 1-6

Operating Procedures----- pg. 1-7

Adjustment and Quality----- pg. 1-8

Technical Specifications----- pg. 1-9

Cleaning and Maintenance----- pg. 1-10

 Changing Cutter----- pg. 1-11

 Replacing and Checking Gaskets----- pg. 1-12

Trouble Shooting----- pg. 1-13

Electrical----- pg. 1-14

Parts Lists----- pg. 1-15--1-17

Tray Carrier Parts Lists----- pg. 1-18--1-19

Warranty----- GEN 050816

Warranty Procedure----- GEN 050817

Returned Parts Policy----- GEN 050818



DESCRIPTION/SPECIFICATIONS

Description

The Oliver Models 1208, 1208-N, and 1208-NLG Heat Sealers are designed and manufactured to ensure a user friendly operation of producing film lidded trays with a cost effective approach.

The manually operated machine operates with a 115 or 230 V.A.C. outlet. The machine was designed to be a compact to limit the amount of table space needed to operate.

Specifications

*Space Requirements, (Shown with Standard Options):
Model 1208 & 1208-N (All Dimensions are Approximate)*

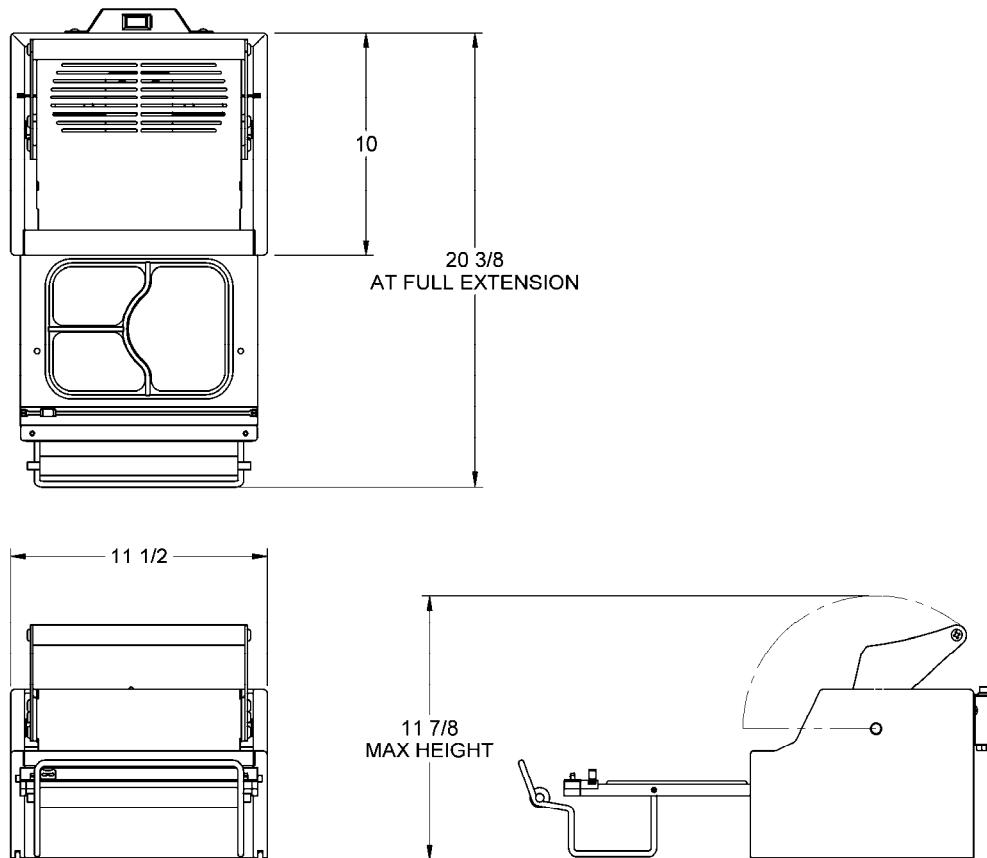

Shipping Weight – 22 lbs. (approximate)

Net Weight – 18 lbs. (approximate)



DESCRIPTION/SPECIFICATIONS CONTINUED

Specifications

*Space Requirements, (Shown with Standard Options):
Model 1208-NLG (All Dimensions are Approximate)*

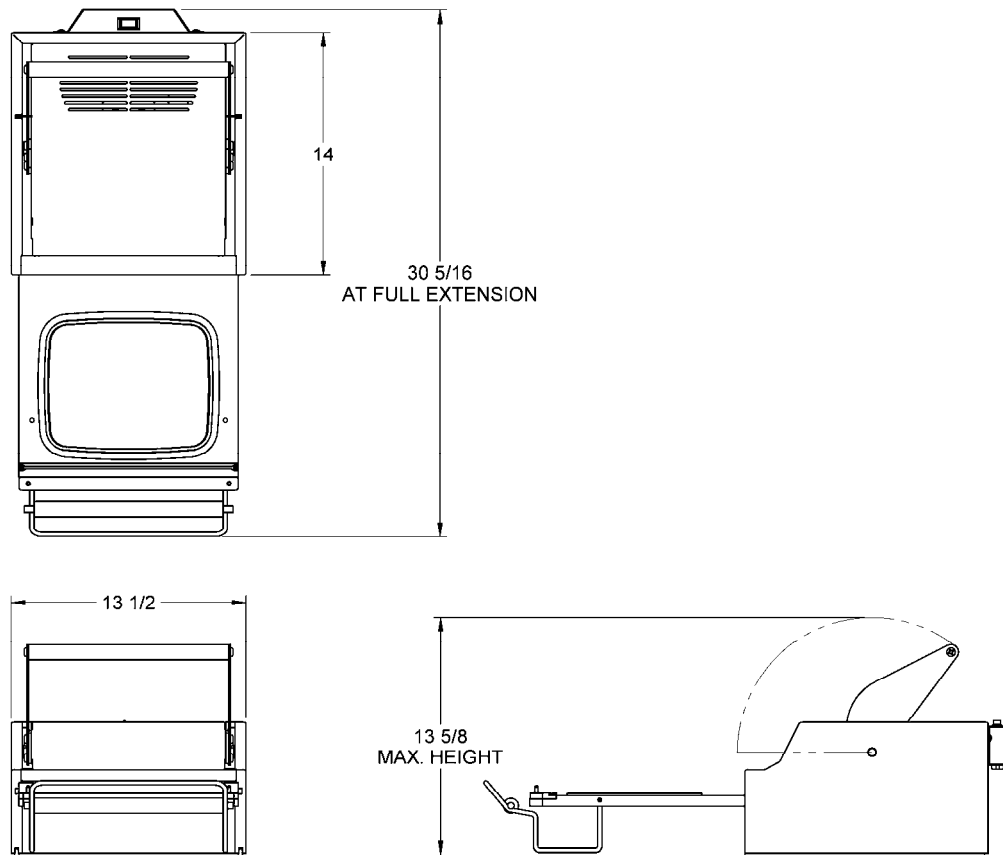

Shipping Weight – 24 lbs. (approximate)

Net Weight – 20 lbs. (approximate)

(REV. 12/18/06)



GENERAL SAFETY INSTRUCTIONS

WARNING

IT IS ESSENTIAL THAT ALL OPERATORS AND MAINTENANCE PERSONNEL OBSERVE THE FOLLOWING SAFETY PRECAUTIONS. IMPROPER INSTALLATION, MAINTENANCE, OR OPERATION OF THIS EQUIPMENT COULD CAUSE SERIOUS INJURY.

1. Read this manual before attempting to operate your heat sealer. Never allow an untrained person to operate or service this unit.
2. Observe all caution and warning labels affixed to the machine.
3. Always unplug the machine before cleaning or servicing.
4. Use only proper replacement parts.
5. Wear proper, personal, protective, safety equipment if necessary.
6. Keep hands away from moving parts of the machine while it is operating.
7. In addition to these general safety instructions, please follow the more specific safety instructions provided throughout the rest of this operating and instruction manual.

WARNING

DO NOT USE FOR OTHER THAN ORIGINALLY INTENDED PURPOSE.



BASIC MACHINE COMPONENTS AND SET UP

Before proceeding further, take a moment to familiarize yourself with the identification of the machine components as shown in the illustration below.

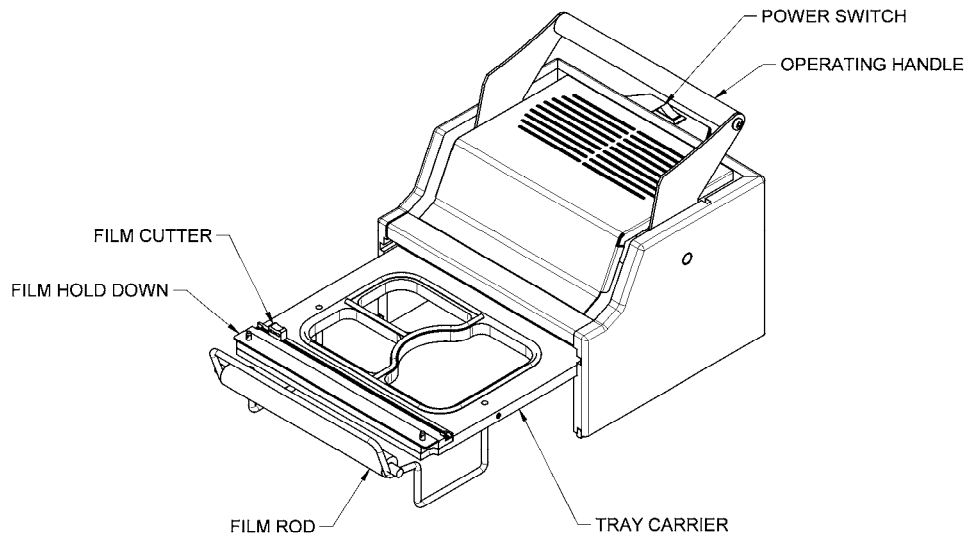

SET UP

1. Carefully remove the Model 1208 from the box. Check to make sure the order is complete, and it has not been damaged during shipment.
2. Place the unit in a suitable location which provides an adequate working space. The location must be sturdy, level, and capable of holding 18lbs. per machine.
3. Remove all packaging materials and shipping restraints such as plastic ties and tape.
4. Raise the handle to full extension.
5. Place film rod into the center of the roll of film.
6. Place film on the machine, and thread film through the film hold down, as shown below.



SET UP CONTINUED

NOTE:

FILM SUPPLIED BY OLIVER PRODUCTS COMPANY IS WOUND WITH THE ADHEASIVE SIDE IN. FEED FILM FROM THE TOP OF THE ROLL AS SHOWN IN DETAIL "A".

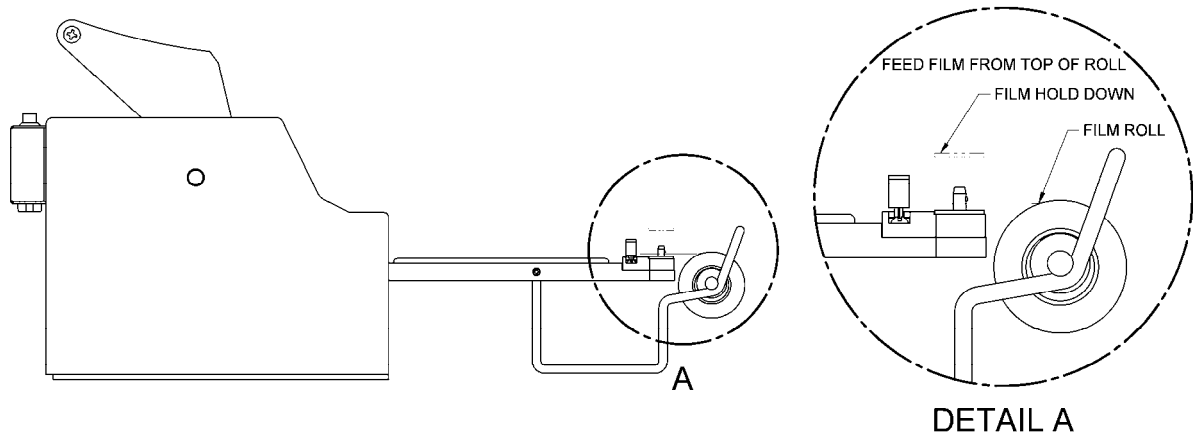



OPERATING PROCEDURES

1. Plug the power cord into a properly grounded outlet. Avoid the use of extension cords. There is a switch on the cover with a light which will illuminate when on.

NOTE: It should take approximately 15 minutes for the machine to warm up to operating temperature.

2. Slide tray carrier out until it stops.
3. Place filled tray in tray carrier. Make sure the food in the tray is not higher than the flange of the tray
4. Grasp the corners of the film and pull it straight across the tray going a ¼ inch past the flange of the tray.
5. Push tray carrier in gently until it stops.
6. Pull handle down with both hands until it stops. Hold the handle down for approximately 2 seconds.
7. Lift the handle to its upright position.
8. Pull tray carrier out.
9. Apply pressure to the film hold down bar with index finger, and with the other hand gently slide the cutter from one side to the other. The cutter works from both directions. In addition, the blade works better with a minimal amount of pressure applied.
10. Remove tray from tray carrier.
11. Repeat steps 4 thru 11

CAUTION

IT IS NOT RECOMMENDED TO LEAVE THE MACHINE ON WHEN IT WILL BE OUT OF OPERATION FOR AN EXTENDED PERIOD OF TIME.



ADJUSTMENT AND QUALITY

Your *OLIVER Model 1208* was tested at the factory using Oliver trays and film.

NOTE

- THE TEMPERATURE CANNOT BE ADJUSTED BY THE OPERATOR
- THE PRESSURE CANNOT BE ADJUSTED BY THE OPERATOR.

The heater platen temperature is factory set at approximately 300 degrees Fahrenheit. Contact the Oliver Service Department if you suspect the heated platen temperature is not correct.

It is necessary to periodically check for a proper seal. This can be done by pull the film over the empty tray carrier, sealing it like normal and pulling the film. If there is a proper seal, the pattern on the film should be a complete outline of the edges of the tray.

A poor seal will occur if the product in the tray contaminates the tray flange. Moisture will have the same affect on the seal. Trays that have irregular flanges or are deformed also seal poorly. Defective trays should be discarded.

Under different operating conditions, it may be necessary to increase or decrease the sealing time. This is done by varying the length of time the operating handle is in the down position. Holding the handle down longer makes the seals stronger. Although a stronger seal may cause shredding or tearing of the film when removing film from tray.



TECHNICAL SPECIFICATIONS

- Temperature Range: Factory preset to approx. 300° F.
- Weight: 18 lbs (1208/1208-N) and 20 lbs (1208-NLG)
- Electrical: 120/230 volts AC (USA) 2/4 Amps ,50-60 Hz
- Finish: White Pebble / Stainless steel
- Max roll diameter: 2" OD
- Max roll width: 8.875" (1208/1208-N)
10.500" (1208-NLG)
- Max. tray size: 8.625" x 6.5" (1208/1208-N)
10.25" x 8.5" (1208-NLG)
- Handle pull down: 15 to 20lb (1208/1208-N)
20 to 30lb (1208-NLG)
- Dielectric breakdown: 1250 for one second
- Constructed of: White HDPE / Stainless steel / Aluminum



CLEANING AND MAINTENANCE

NOTE

- These cleaning recommendations are not meant to replace plant standard manufacturing procedures or regulatory requirements.
- If the machine has been in operation, allow the unit to cool before cleaning.
- Tray carrier is NOT recommended for automatic dishwashers

CAUTION

- **CAUTION HOT:** The heated platen is **HOT!** Caution must be used to prevent injury from heated platen.

WARNING

- Make sure the unit has been unplugged for a minimum one hour before cleaning.
- It is important that the surface of the heater platen is kept clean and smooth. Regularly clean the *OLIVER Model 1208* with a mild cleaner and a damp cloth. If food product comes in contact with the surface of the platen, it tends to burn on and become hard. This results in an irregular surface on the face of the platen which can result in poor seals. If this happens, it will be necessary to remove this contaminate material. When cleaning care must be taken to avoid scratching or gouging the surface of the platen. **DO NOT SCRAPE THE SURFACE OF THE PLATEN WITH SHARP OBJECTS AND AVOID THE USE OF METAL TOOLS.** The use of plastic or soft-metal scouring pads such as “SCOTCH BRITE” or “CHORE BOY” provides a safe and effective means of cleaning the platen. Be sure to wipe all surfaces with a sanitizing agent after cleaning.

WARNING

- If it is necessary to the clean the platen while it is still hot although not recommended, be sure to use something such as a hot pad glove to protect your skin.



CLEANING PROCEDURES

1. Remove tray carrier by pushing the carrier in, lifting the tray carrier straight up, and then pull out.
2. Wipe down tray carrier and gaskets with a standard cleaning solution.
3. Tip the machine up on its side, and then wipe off the heated platen.
4. Wipe sides, top and handle of the machine.
5. Replace tray carrier

CHANGING CUTTER BLADE

1. Remove tray carrier, as described above
2. Use a flat head screw driver to remove one of the screws on either end of the cutter track
3. Replace old cutter with new
4. Replace and retighten screw



REPLACING AND CHECKING GASKETS

- If there are any gouges, cuts or gaps in the gasket, the gasket will have to be replaced.
- Be sure to replace all the gaskets not just the piece that is damaged.
- When reinstalling gaskets, the gasket must be seated all the way down in the groove.
- Do not stretch gasket when reinstalling.
- After the new gaskets are installed, place the tray carrier up side down on a flat surface and check to see if the newly installed gasket is even.
- If not even, depress or lift gasket to provide an even heat sealing surface.
- It is necessary to periodically check for a proper seal. This can be done by pull the film over the empty tray carrier, sealing it like normal and pulling the film. If there is a proper seal, the pattern on the film should be a complete outline of the edges of the tray.



TROUBLE SHOOTING

SYMPTOM

CORRECTIVE ACTION

Poor seal quality

Verify that the platen is heated and is at the correct temperature (approximately 300° F)

Check to see if the platen is dirty

Check rubber gasket on tray holder for damaged or missing pieces

Platen does not heat up

Verify that the power cord is plugged into outlet

Verify that there is power at the outlet

Film does not cut

Check that the film is threaded properly

Be sure the film hold down bar is in place above the film.

Film sticking to heater

Film is coming off the roll the wrong direction or improper threading.

Shredding film

Holding sealer down for more than 2 sec. may cause this.



ELECTRICAL 1-60-120

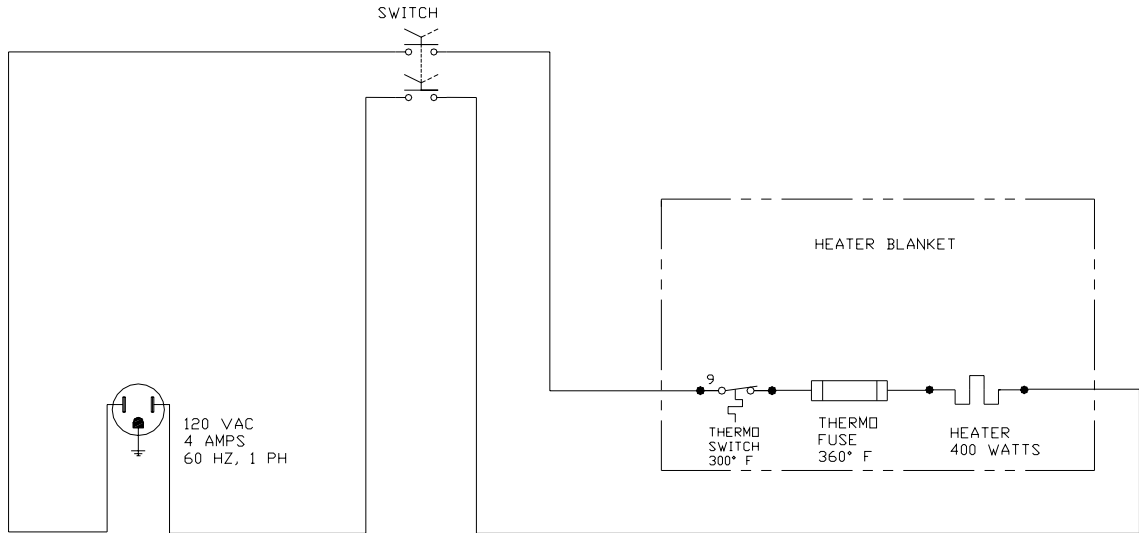

ELECTRICS 1-60-230

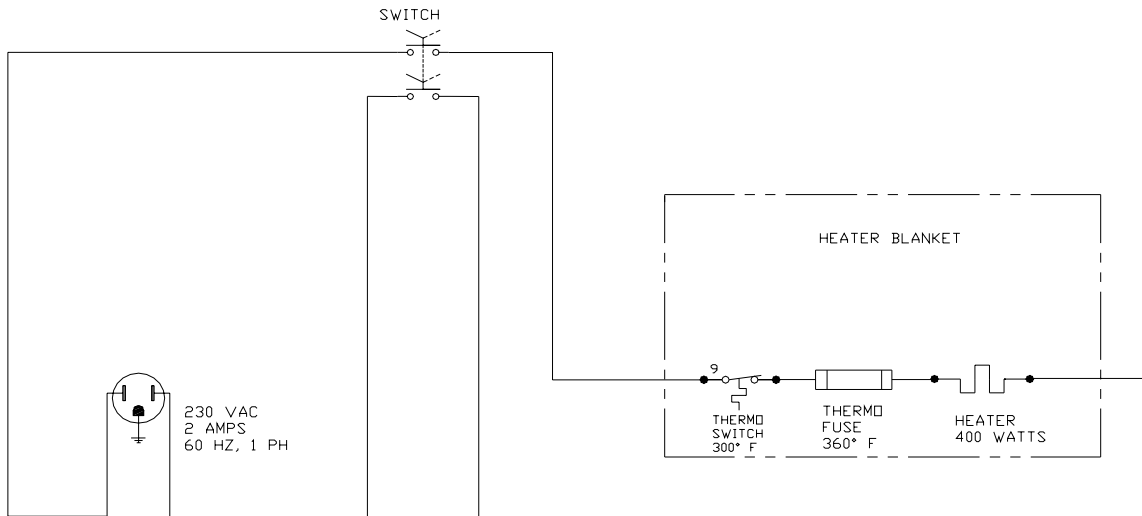



MODEL 1208 & 1208-N HEAT SEALER

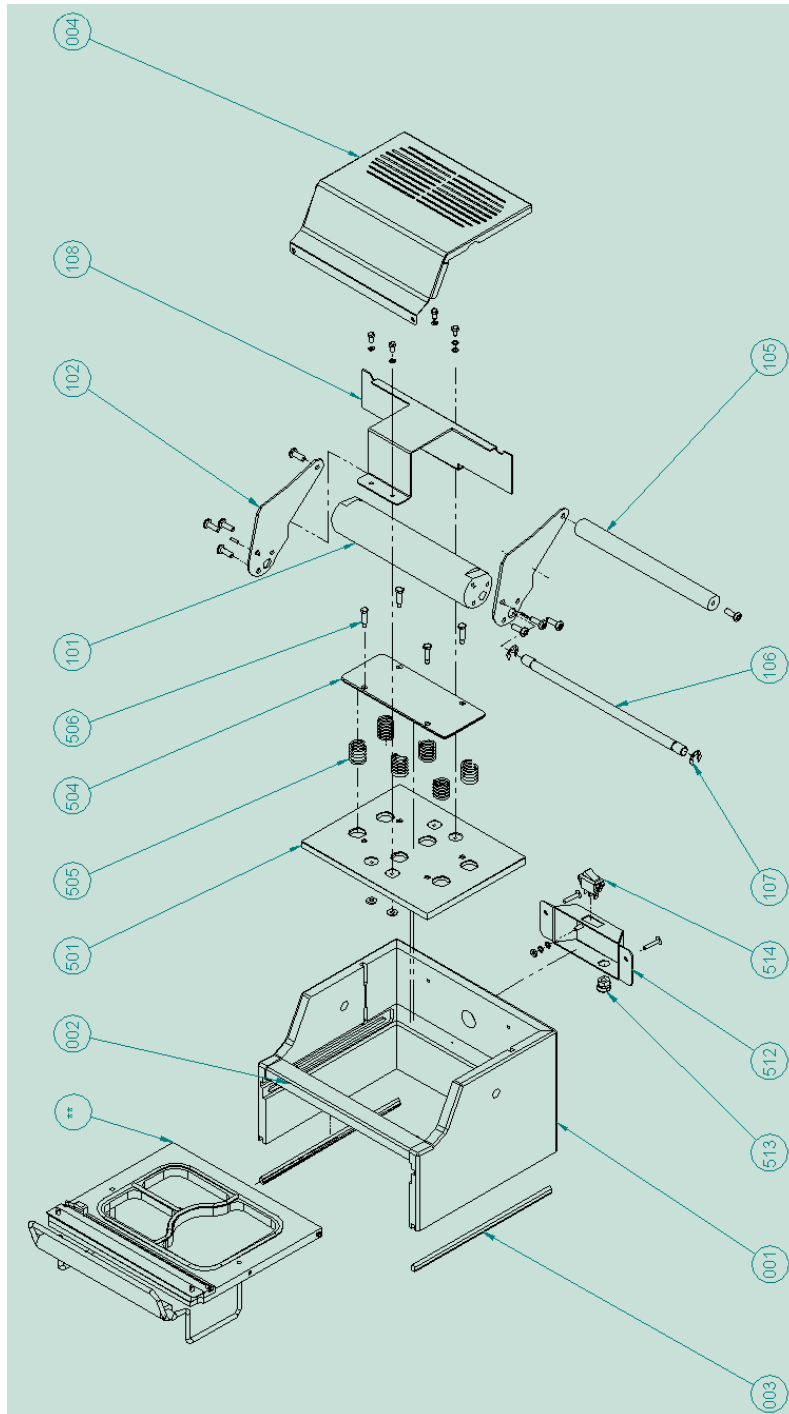



**MODEL 1208 & 1208-N HEAT SEALER PARTS LISTS
(PART NUMBERS SHOWN IN BOLD ARE FOR 1208-NLG)**

ITEM NO	PART DESCRIPTION	PART NUMBER
001	Frame Assembly	1208-0001
001	Frame Assembly (LG)	1208-0001-002
002	Spacer-Front	1208-0001-0043
002	Spacer-Front (LG)	1208-0001-0053
003	Cushion-Gray Silicone Extruded	6516-0020
004	Cover	1208-0009
004	Cover (LG)	1208-0009-002
101	Cam-Pusher	1208-0005
101	Cam-Pusher (LG)	1208-0005-101
102	Arm	1208-0006
102	Arm (LG)	1208-0006-101
105	Handle-Arm	1208-0007
105	Handle-Arm (LG)	1208-0007-001
106	Shaft-Cam	1208-0010
106	Shaft-Cam (LG)	1208-0010-001
107	Ring-Retaining	5840-1280
108	Lifter-Cam	1208-0008
108	Lifter-Cam (LG)	1208-0008-002
501	Plate-Heater (115V)	1208-0033-1
501	Plate-Heater (230V)	1208-0033-101
501	Plate-Heater (120V LG)	1208-0033-102
501	Plate-Heater (230V LG)	1208-0033-103
504	Retainer-Spring Plate	1208-0019
505	Spring-Compression	7014-3106
505	Spring-Compression (.100")	7015-2200

(REV. 7-8-08)



Oliver Packaging & Equipment Company
511 Sixth Street NW • Grand Rapids, MI 49504

(800) 253-3893
www.oliverquality.com

PARTS LIST CONTINUED

506	Screw-1/4" Dia. x 3/4" Shoulder	4560-0908-1201
512	Cover-Electrical	1208-0021-002
512	Cover-Electrical (LG)	1208-0021-003
513	Bushing-Strain Relief	5765-1076
514	Switch-Rocker on/off	5757-3313
**	Tray Carrier Components	See Pg. 1-16

FOR SERVICE PARTS CALL OLIVER PRODUCTS @ 800-253-3893



MODEL 1208 & 1208-N TRAY CARRIER

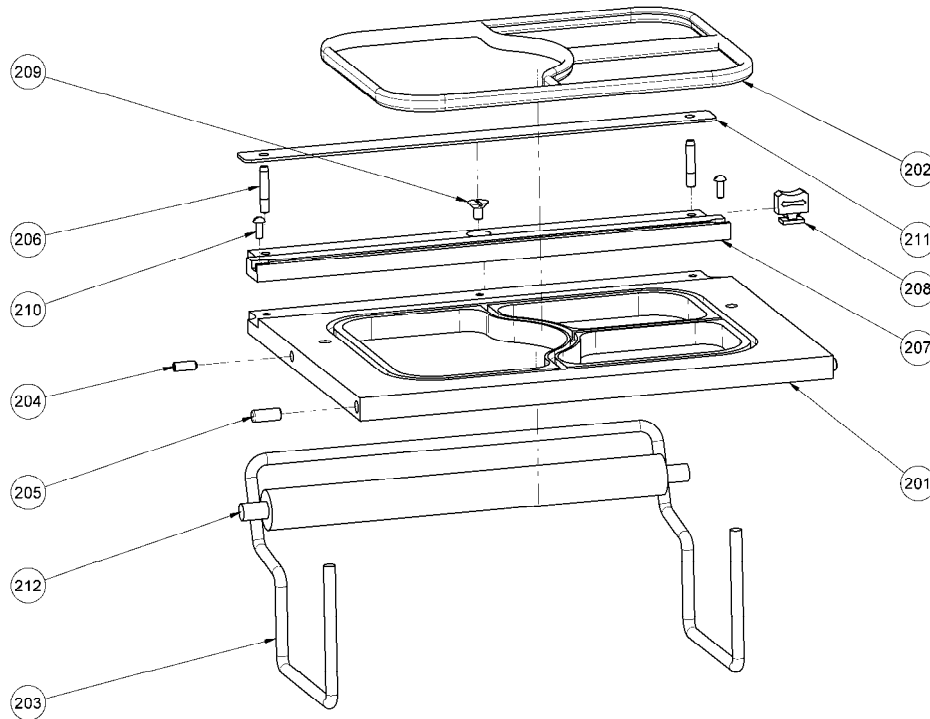

MODEL 1208 & 1208-N TRAY CARRIER PARTS LISTS

ITEM NO	PART DESCRIPTION	PART NUMBER
201*	Carrier-Tray 3 Compartment	1208-0013-500
202**	Cushion-White Silicone Extruded	6516-0028
203	Rod-Film Holder	1208-0014
203	Rod-Film Holder (LG)	1208-0014-001
204	Screw-10-24 x 1" STST Set	5843-2024
205	Pin-1/4" x 5/8" STST Dowel	5835-6474
206	Pin-3/16" x 1/2" STST Quick Release	5835-7800
207	Slitter-T-Slot	1208-0016
207	Slitter-T-Slot (LG)	1208-0016-002

FOR SERVICE PARTS CALL OLIVER PRODUCTS @ 800-253-3893



TRAY CARRIER PART LIST CONTINUED

208	Cutter-Slide	5903-5600
209	Stud-10-24 x 1/2" STST Weld	5843-5067
210	Screw-Rnd. Hd. 6/32 x 3/8" STST	5843-5211
211	Hold Down-Film	1208-0012
211	Hold Down-Film (LG)	1208-0012-001
212	Tube-Film	1208-0015
212	Tube-Film	1208-0015-001

* Tray carries do not come with stock units. They are ordered separate and customized based on the tray that is being used in the sealing operation.

** Cushions differ from tray carrier to tray carrier. The cushion that is used is determined by the engineer during the design process.

FOR SERVICE PARTS CALL OLIVER PRODUCTS @ 800-253-3893