

PRODUCT INFORMATION:

SC-400 PreciseCoat™ Jet

SC-400 PreciseCoat™ Conformal Coating Jet

Highly selective, precision jet coating

The SC-400 PreciseCoat™ Conformal Coating Jet is ideal for applying coating materials to highly selective areas. This solution is designed for coating small substrates or substrates with high-component density, and when there are tight tolerances between coated and uncoated areas.

The SC-400 jet reaches locations not accessible by other applicators, using a needle design with jetting action and fast pulse-width modulated control. Small volumes and better control of the material deliver line widths down to 1.5 mm (0.05 in.) wide. The need for masking is eliminated because the flow is so closely controlled. Film thicknesses of 15 micrometers are achievable when using solvent-based materials.

A dual-valve configuration is available if your operation requires larger area coverage in addition to highly selective coating. This configuration combines the precision of the SC-400 jet with the fast, wide-area coverage of other applicators, like the SC-300 or the SC-104/204 Film Coater applicators.

Additional benefits of the SC-400 jet make its use in production even more valuable. Multiple dot sizes can be delivered from the same applicator, yielding small volumes with good volume control. The SC-400 also allows for clearance above large components on a board, and its performance is not affected by warped substrates.

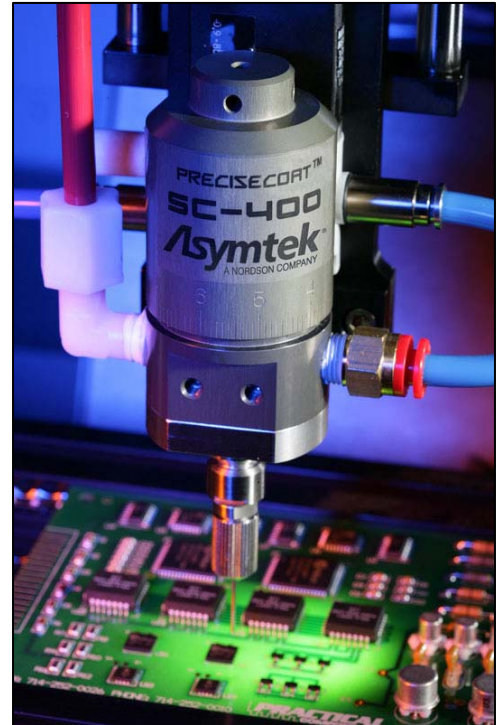

FEATURES & BENEFITS

- Highly selective jetting of coating materials
- Reaches locations not possible with other applicators
- Dot sizes to 1.5 mm (0.05 in.)
- Thinner film builds, to 15 µm
- Fast, up to 500 mm/sec (20 in/sec)
- Eliminates the need for masking
- Easy to disassemble and maintain

Asymtek[®]
A NORDSON COMPANY

Packaging - Processing

Bid on Equipment

1-847-683-7720

www.bid-on-equipment.com

SC-400 Jet Specifications

For use on Asymtek's Century® Series conformal coating systems

Operation: Electrically controlled, air open, spring close

Valve Pressure: 413 kPa (60 psi) minimum

Dimensions: see diagram

Weight: 500 gm (1.1 Lb)

Typical Fluid Dispense Pressure: 21-345 kPa (3 and 50 psi)

Max/Min Needle length:
13 mm (0.5 inch)/ 6 mm (0.25 inch)

Coating velocity: 125 – 500 mm/sec (5-20 in./sec)

Pulse Width Controller, integrated to coating platform

Pulse controlled by EasyCoat® for Windows XP software

Application Parameters

Tested chemistries: Acrylics, silicones, urethanes, UV-cure, water-based

Tested materials viscosity range: 0 to 850 cps
For higher viscosities, contact the factory.

Max. deposition speed: 500 mm/sec

Dot size down to: 1.2 mm +/-0.06 mm

Option

Needle sensor: Accurately positions the needle tip (to provide closed-loop positioning of the needle tip).

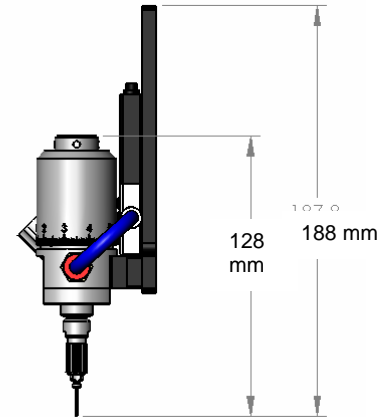
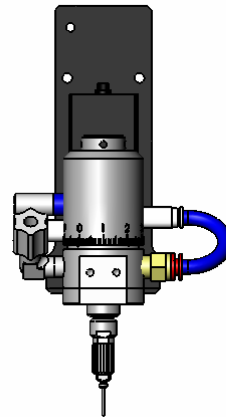
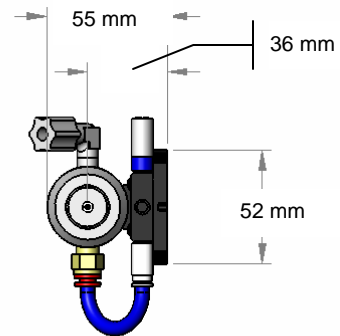

Please contact these locations for the name of your local representative:

HEADQUARTERS
2762 Loker Avenue West
Carlsbad, CA 92008-6603 USA
U.S. (toll free): 1-800-ASYMTEK
Tel: (760) 431-1919
Fax: (760) 431-2678
Email: info@asymtek.com

INTERNATIONAL SALES
Europe: +31 (0) 43-352-4466
China: +86-21-5899-1879
Japan: +81 (0) 3-5762-2801
Korea: +82-31-765-8337
S.E. Asia: +65 6796-9515
Taiwan: +886-2-2902-1860
www.asymtek.com
www.asymtek.com.cn

PreciseCoat™ is a trademark and Asymtek® and Century® are registered trademarks of Asymtek.. EasyCoat® and Nordson® are registered trademarks of Nordson Corporation. Windows® is a registered trademark of Microsoft, Inc.

Asymtek reserves the right to make design changes to products to improve their function. These changes may occur between printings.

Contact Asymtek for your specific application requirements.

Asymtek is ISO 9001:2000 Certified
Asymtek is the recipient of Intel Corporation's SCQI Award in 2003, 2004 and 2005
©2007 Asymtek Published 9 February 2007