



PURBlue™ EC Melter

New melter efficiently handles reactive adhesive materials with easy clean-up and maintenance.

The Nordson® PURBlue EC melter was developed to better meet the special requirements of processing reactive materials. PURBlue EC melters process material in a way that protects adhesive characteristics to help improve bonding consistency and product quality.

The unique easy-to-clean concept* means all components in contact with PUR, such as tank, grid, reservoir and even the pump-block, can be quickly, and to a large extent without tools, dismantled for cleaning. To further simplify maintenance, PURBlue EC melters have pump shutoff valves and quick-disconnect heater and sensor cables.

In addition to easy maintenance, PURBlue EC melters provide graphical, intuitive controls along with week/day timer for easy day-to-day operation.

By combining ease of operation and maintenance with consistent reactive adhesive processing, PURBlue EC melters help increase productivity and reduce waste.



Features and Benefits

- Easy-to-clean design, quick-disconnect cables and purge function simplify and reduce cost of maintenance.
- User-friendly controls, week day timer and I/O interface make operation easy.
- Inert gas blanket protects adhesive from moisture to prevent premature curing.
- Variable speed with key-to-line operation.
- Accommodates 18 kg (39.68 lb) adhesive slug at 280 mm (11 in) diameter.

* patent pending

PURBlue™ EC melter



Tiltable tank for easy cleaning



Quick-disconnect grid plate for easy access to reservoir

Technical Specifications

Voltage	400 VAC 3ph
Melt Rate*	20 kg/hr (44.09 lbs/hr)
Foil Bag	280 mm (11 in diameter)
Reservoir Capacity	2.2 kg (4.85 lbs)
Temperature Sensor	Ni120
Pump Type	positive displacement gear
Operating Temperature	40 to 230° C (104 to 446° F)
Max. System Power Capacity	13.6 KW/ 24A
Hose / Gun Pairs	2 (4 external channels)
Weight	approx. 180kg (396.83 lbs)
Protection	IP54

*depending on adhesive type

Dimensions

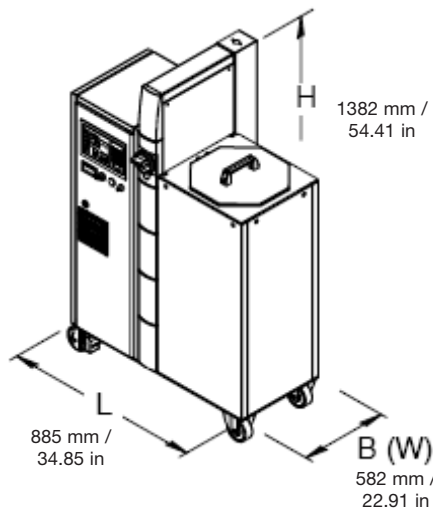

Options

3 selectable pump sizes:

- SN0093 (PR6m1)
- SN0186 (PR12m1)
- SN0773 (PR25m2)



For more information, talk with your Nordson representative or contact your Nordson regional office.

United States
Duluth, Georgia
Tel: (800) 683-2314
Fax: (866) 667-3329

Canada
Markham, Ontario
Tel: (800) 463-3200
Fax: (905) 475-8821

Europe
Lüneburg, Germany
Tel: (49) 4131-894-0
Fax: (49) 4131-894-149

Japan
Tokyo, Japan
Tel: (81) 3-5762-2700
Fax: (81) 3-5762-2701

**Asia/Australia/
Latin America**
Amherst, Ohio
Tel: (440) 985-4797
Fax: (440) 985-1096

www.nordson.com



© 2007 Nordson Corporation
All rights reserved.
Nordson reserves the right
to make design changes between printings.

Packaging - Processing
Bid on Equipment
1-847-683-7720
www.bid-on-equipment.com