

PWII 350 Profile Wrapping Application Head

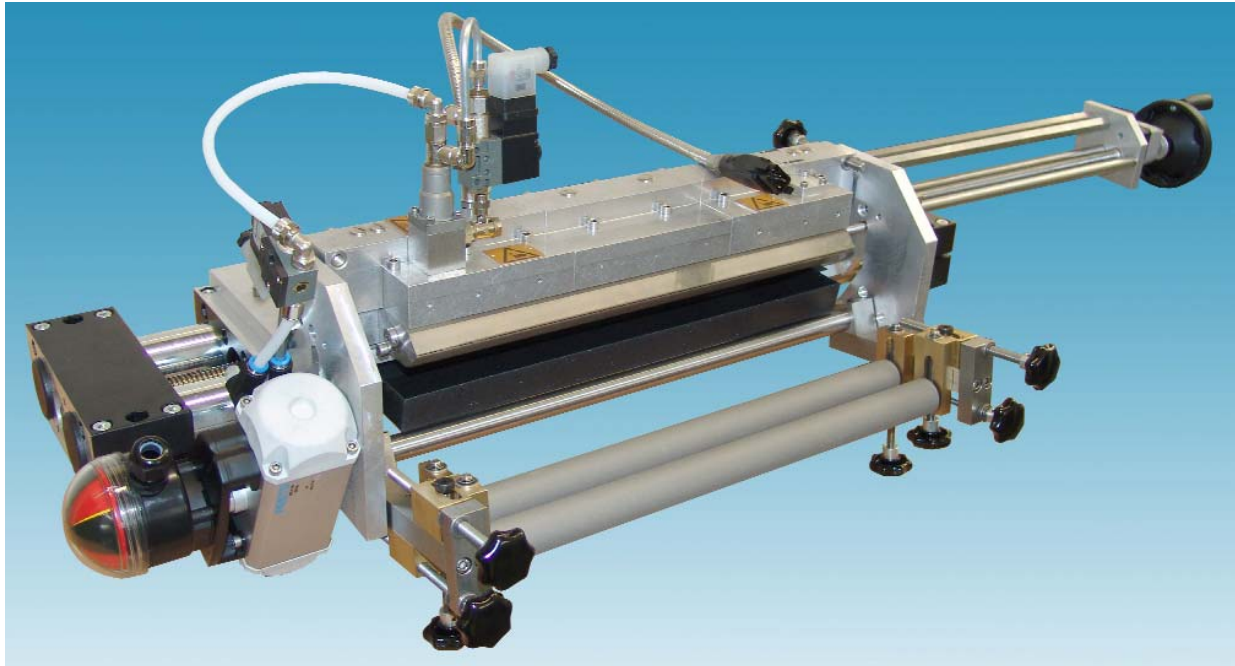

Achieve high-quality adhesive application from customizable profile wrapping application head.



With a design ideally suited to process veneer as well as continuous-pressure laminate (CPL) and high-pressure laminate (HPL), the Nordson® PWII 350 applicator sets a new standard. PWII 350 application heads can apply a wide variety of adhesives to vinyl, veneer, foils or paper which are then immediately applied to profiles of varying shapes and materials.

The coating width and position of the head to the substrate can be easily adjusted even during production.

The PWII 350 head is part of a closed system that also includes a tank or bulk melter and a heated hose. The closed system keeps moisture and contaminants out of the system to help improve bonding quality and reduce maintenance. Closed systems are particularly well-suited to handling reactive polyurethane (PUR) adhesives.

Precise metering and accurate temperature control help reduce adhesive consumption and improve product quality.

Features and Benefits

- Coating width can be adjusted from 10 to 350 mm (0.39 to 13.8 in.), even during production.
- Applicator is customized by configurable number of modules, exchangeable nozzle assemblies and user-friendly web guides.
- Uniform, optimum adhesive distribution yields high product quality and reduces adhesive consumption.
- Easy conversion from left-hand to right-hand versions and an integrated drip pan contribute to simple operation and maintenance.
- Options include special nozzles for highly abrasive materials and a sliding gun bracket.

PWII 350 Profile Wrapping Application Head

Technical Specifications

Operating Temperature	max. 200° C (392° F)
Adhesive Pressure	max. 7 MPa/ 70 bar (1015 psi)
Pattern Width	10 to 350 mm (0.39 to 13.8 in)
Temperature Sensors	Ni120 and PT100
Control Air Pressure	0.6 MPa/ 6 bar (87 psi)
Voltage	230 VAC
Control Voltage	24 VDC
Power	1000 W
Weight	approx. 50kg (110 lbs)

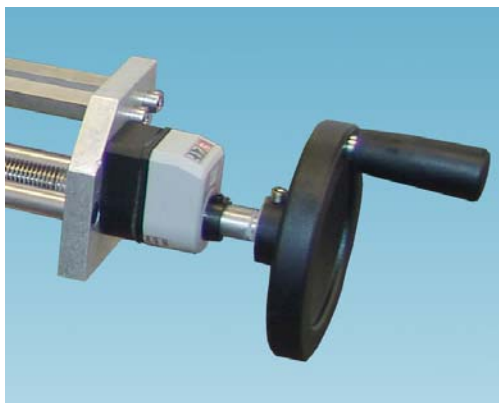

Optionally available handwheel



New configurable filter unit



Quick exchange nozzle

Dimensions*

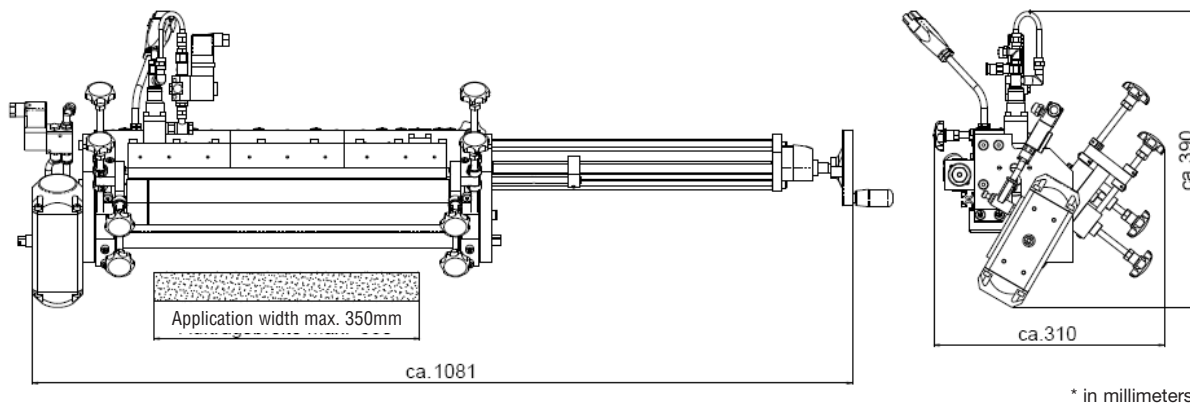

For more information, talk with your Nordson representative or contact your Nordson regional office.

United States

Duluth, Georgia
Telephone: (800) 683-2314
Facsimile: (866) 667-3329

Canada

Markham, Ontario
Telephone: (800) 463-3200
Facsimile: (905) 475-8821

Europe

Lüneburg, Germany
Telephone: (49) 4131-894-0
Facsimile: (49) 4131-894-149

Japan

Tokyo, Japan
Telephone: (81) 3-5762-2700
Facsimile: (81) 3-5762-2701

Asia/Australia/ Latin America

Amherst, Ohio
Telephone: (440) 985-4797
Facsimile: (440) 985-1096

www.nordson.com



When you expect more.®

© 2007 Nordson Corporation
All Rights Reserved.
Nordson reserves the right
to make design changes between printings.

Nordson Corporation • 11475 Lakefield Drive • Duluth, Georgia 30097-1511



Packaging - Processing
Bid on Equipment
1-847-683-7720
www.bid-on-equipment.com