

PC56 Pattern Control



High-speed programmable pattern control delivers precise adhesive placement at line speeds exceeding 2000 feet per minute.

The Nordson® PC56 Pattern Control is the newest addition to the PC50 Series. This family of controls uses advanced microprocessor technology to provide high-resolution, precise pattern deposition. Controls can function independently or be interfaced to PLCs in larger automated systems.

The Model PC56 is designed for high-speed applications which require precise adhesive placement control and product position or placement monitoring. The PC56 performs easily at line speeds exceeding 2000 ft/min.

The PC56 offers product skew and overlap protection to minimize waste in applications such as straight-line folder gluing.

The PC56 is easy to install.

The PC56 is configured for ease of installation and simple setup. It is available in a NEMA-12 enclosure with power supply and is shipped fully assembled and ready for mounting and wiring. The PC56 is also available in modular form for custom installation in a parent machine.

Features and Benefits

- Multi-turn resolver line-speed tracking allows for wide variations in product size and position without special gearing.
- Unique setup counter simplifies initial setup and programming by allowing measurement of product length and distance through the controller.



- Memory trigger feature allows tracking of up to 14 products simultaneously, enabling flexible photo sensor installation.
- +0/-1 mm accuracy at 2000 ft/min (610 m/min) meets the most demanding high-speed application requirements.
- 50 microsecond response time provides exceptional accuracy for high-speed production lines such as folder gluers.
- Up to seven independent output channels handle complex patterns.
- 32 program memories store patterns for fast changeovers.
- Two levels of security password protection guard against unauthorized adjustments.
- Run-up output controls pneumatic piston pumps, pressure regulators or spray air.
- Product length fault detection identifies skewed or overlapped product preventing improper gluing. A dedicated output can be used to activate warnings and/or reject.
- Fast adhesive bead volume adjustment helps achieve optimum adhesive deposition.
- Product counter records pieces produced.
- Programmable trigger disarm capability helps distinguish between leading edge of product and product window.
- False trigger recognition prevents misfiring at scrap.
- Easy-access gun purge feature allows for fast purge of each gun channel.
- Enhanced rate display reads in either line speed or products per minute.
- Standard serial communication port allows memory upload/download through any standard PC.
- Modbus communication capability allows interface with machine controls through standard industrial interface protocols.

Nordson® PC56 Pattern Control



Serial communications option allows program upload/download and remote controller operation.



Modular components offer installation flexibility.

Dimensions

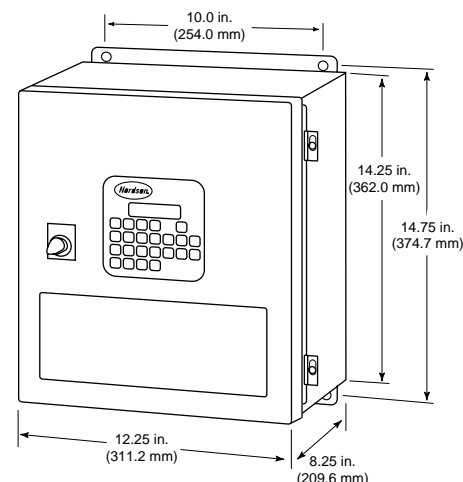

Specifications

Maximum Line Speed:	2000 ft/min (610 m/min)
Accuracy:	+0 / -.040 in @ 2000 ft/min (+0 / -1 mm @ 610 m/min)
Line Speed Transducer:	Multi-turn resolver
Operation:	
Response Time:	50 μ Sec
Position Resolution:	12 bits - 4096 increments, maximum
Gun Compensation:	Leading/trailing edge, 0.1 msec steps, each output independent
Program Memories:	32

Inputs/Outputs:

- 1 trigger input
- Up to 8 output modules*
- 1 run-up output
- 1 skew/overlap fault output

*Output modules may be any mix of AC, DC and one analog.

Run-up Output:

Output Type:	4-20 mA or 0-10 VDC, proportional to RPM (line speed)
Resolution:	12 bit
Update Frequency:	100 msec

Input Electrical:¹

Primary power supply input:	110/240 VAC 50/60 Hz
Controller-only input:	20-30 VDC

Mounting:

Complete Assembly:	See diagram
Weight: (complete assy):	30 lb (13.6 kg)
Controller only:	EN-50035 ("G" profile) or EN-50022 ("Top Hat" profile) DIN rail.
Keypad/Display only:	May be mounted up to 1000 ft (305 m) from controller.

Serial Communication:

RS232/RS435; 4800, 9600, 19.2K, 38.4K Baud Rate

Approvals:

UL, CE

Notes:

1. Current power supply requirement is determined by the number of gun solenoids to be activated and their collective requirements.

Specifications subject to change without notice.



Nordson Corporation
11475 Lakefield Drive
Duluth, Georgia 30155-1511
Toll Free (800) 683-2314
Internet: www.nordson.com