

# PC50 Series Pattern Controls



Programmable pattern controls deliver precise adhesive placement for packaging and product assembly applications.

Nordson PC50 Series Pattern Controls manage adhesive placement for high-speed, complex applications. This family of controls uses advanced microprocessor technology to provide high-resolution, precise pattern deposition at high line speeds, and can function independently or be interfaced to PLCs in larger automated systems.

Typical applications for PC50 Series controls include high-speed cartoning, sift-proof and beverage cartoning, product assembly and other operations requiring multiple outputs and memories.

The Model PC54 pattern control stores 16 programs in memory, and is designed for high-speed, multifunction applications. With up to 64 programs in memory, the Model PC55 pattern control is ideal for even more involved applications requiring frequent changeovers, numerous outputs and additional input control.

The PC50 Series controls expertly handle complex functions under changing line conditions. Each control stores multiple timing setpoint programs for adhesive guns, allowing quick changeover in product size or configuration. This reduces downtime, improves productivity and frees operators for other tasks.

## PC50 Series meets varied application requirements.

- Resolver line-speed tracking allows quick response to changes in line speeds.
- Individual gun compensation keeps patterns in place while line speeds change.



- Individual outputs can be stitched to conserve adhesive and meet specific applications like easy-open cartons.
- Speed enable/disable turns selected outputs on or off at specified machine speeds to ensure consistent, quality adhesive placement.
- Serial communications interface permits easy memory upload/download to a disk file. It also allows remote programming and operation using optional communications software on any standard personal computer.
- Optional run-up output allows PC50 Series controls to drive up to two I-P transducers or other similar devices. Output signals from the PC50 Series are linearly proportional to parent machine speed. No measuring equipment or calibration is required for initial setup.

## The PC50 Series eases installation.

Both the PC54 and PC55 are configured for ease of installation and retrofit. Each system is available in a NEMA-12 enclosure with power supply and is shipped fully assembled and ready for mounting and wiring. Both the PC54 and PC55 are also available in modular form for custom installation in a parent machine.

Several installation options are available, including a keyboard boot. This clear silicon rubber seal fits over and around the keyboard to protect it from dirt and chemicals. The controls can also be configured to meet waterwash requirements up to NEMA-4X ratings.

# Nordson® PC50 Series Pattern Controls

## Features and Benefits

- Up to 17 independent output channels handle the most demanding multiple-gun applications.
- Up to 64 program memories store complete patterns for fast changeovers.
- Up to 4,096 increments per resolver revolution allow each output channel to be configured to produce intricate patterns.
- User-selectable scale factor allows custom programming for precise application resolution.
- The PC55 drives up to two independent run-up outputs, such as pneumatic pump and spray air, for multifunction control.
- Up to six independent trigger inputs can be linked to specific outputs. This flexibility improves control of the product sealing process by verifying such variables as product position, open flaps and reject functions.
- Two levels of security password protection guard against unauthorized adjustments.
- Standard serial communication port allows memory upload/download and remote programming using optional communications software on any standard PC.
- PC55 modbus communication capability allows interface with machine controls through standard industrial interface protocols.

## Specifications

### Operation:

Scan Time: 250 - 500 µsec

### Position Resolution:

- 10 bits - PC54 (1024 increments)
- 12 bits - PC55 (4096 increments)

Gun Compensation: Leading/trailing edge, 0.1 msec steps, each output independent

### Multiple Programs:

- PC54 - 16
- PC55 - 64

### Inputs/Outputs:

PC54: Up to 2 trigger inputs  
Up to 8 output modules\*  
1 run-up output



Serial communications option allows program upload/download and remote controller operation.

PC55: Up to 6 trigger inputs  
Up to 17 output modules\*  
Up to 2 run-up outputs

\*Output modules may be any mix of AC and DC, and up to two analog.

### Run-up Outputs:

Output Type: 4-20 mA or 0-10 VDC, proportional to RPM

Resolution: 12 bit

Update Frequency: 100 msec

Linearity: ±0.2% @ 77°F (25°C)

### Input Electrical:<sup>1</sup>

Primary power supply input:  
110/240 VAC 50/60 Hz

Controller only input: 20-30 VDC

### Mounting:

Complete Assembly: See diagram

Weight (complete assy):  
30 lb (13.6 kg)

### Controller only:

EN-50035 ("G" profile) or  
EN-50022 ("Top Hat" profile)  
DIN rail.

### Keypad/Display only:

May be mounted up to 1000 ft  
(305 m) from controller.  
With PC55, up to two keypads  
may be connected to one  
controller.

### Serial Communication:

RS232/RS435; 4800, 9600,  
19.2K, 38.4K Baud Rate

### Approvals: UL



Modular components offer installation flexibility.

### Notes:

1. Current power supply requirement is determined by the number of gun solenoids to be activated and their collective requirements.

Specifications subject to change without notice.

## Dimensions

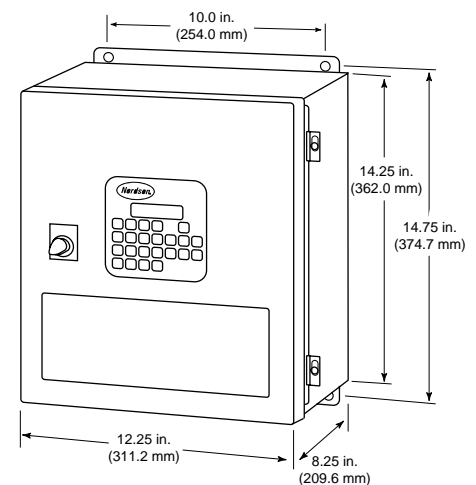

Nordson Corporation  
11475 Lakefield Drive  
Duluth, Georgia 30155-1511  
Toll Free (800) 683-2314