

LA 825 Liquid Adhesive Dispensing Electric Applicators



Rapid-cycling LA 825 applicators deliver precise bead application in high-speed production processes for consistent, high quality bonding.

High-performance LA 825 electric applicators feature:

- 250Hz *continuous* cycle rate
- Sharp cutoff
- Highly-accurate, consistent flow control due to improved stroke adjustment
- Optional LED for better visibility of activation status

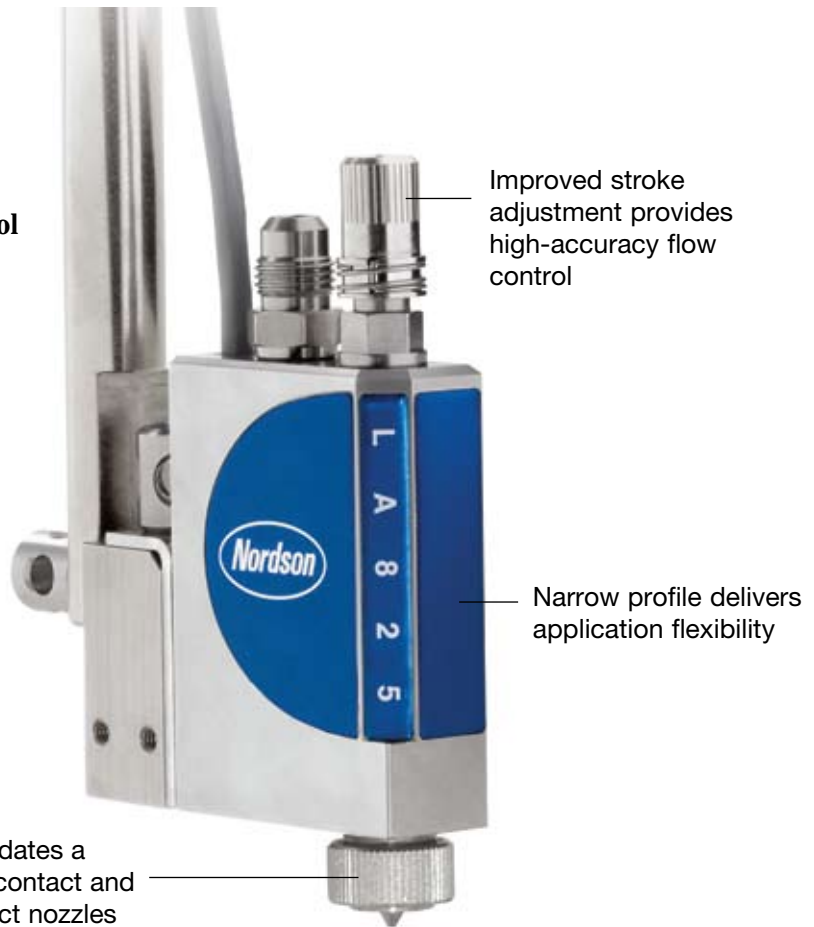

Nordson LA 825 electric guns are ideal for the small adhesive quantities, intermittent application, and high-line speeds found primarily in paper and paperboard converting industries. The fast-cycling guns maintain consistent adhesive deposition even during line speed changes.

LA 825 applicators accommodate a variety of contact nozzles as well as non-contact bead nozzles. Along with the compact design and independent stroke adjustment, this makes the LA 825 applicator the preferred choice when flexible gun configurations are required.

The LA 825 applicator's new design with a single-piece stainless-steel housing and superb engineered armature increases durability thus helping prolong service life and production uptime.

LA 825 Liquid Adhesive Dispensing Electric Guns

Specifications

Maximum Hydraulic Pressure	20 bar (290 psi)
Maximum Continuous Cycle Rate	250Hz
Maximum Intermittent Cycle Rate	500Hz*
Viscosity	Up to 1500 cps (linear up to 1200 cps)
Nozzle Diameter Range	
Non-contact	0.3, 0.35, 0.4, 0.5, 0.6, 0.7 mm (0.012, 0.014, 0.016, 0.020, 0.240, 0.028 in.)
Contact	0.3, 0.4, 0.5, 0.6, 0.7, 1.0 mm (0.012, 0.016, 0.020, 0.240, 0.028, 0.04 in.)
Connection Fittings	1/2-20 UNF
Ingress Protection Class	IP65

* depending on pressure, viscosity, flow rate and cycle duty.

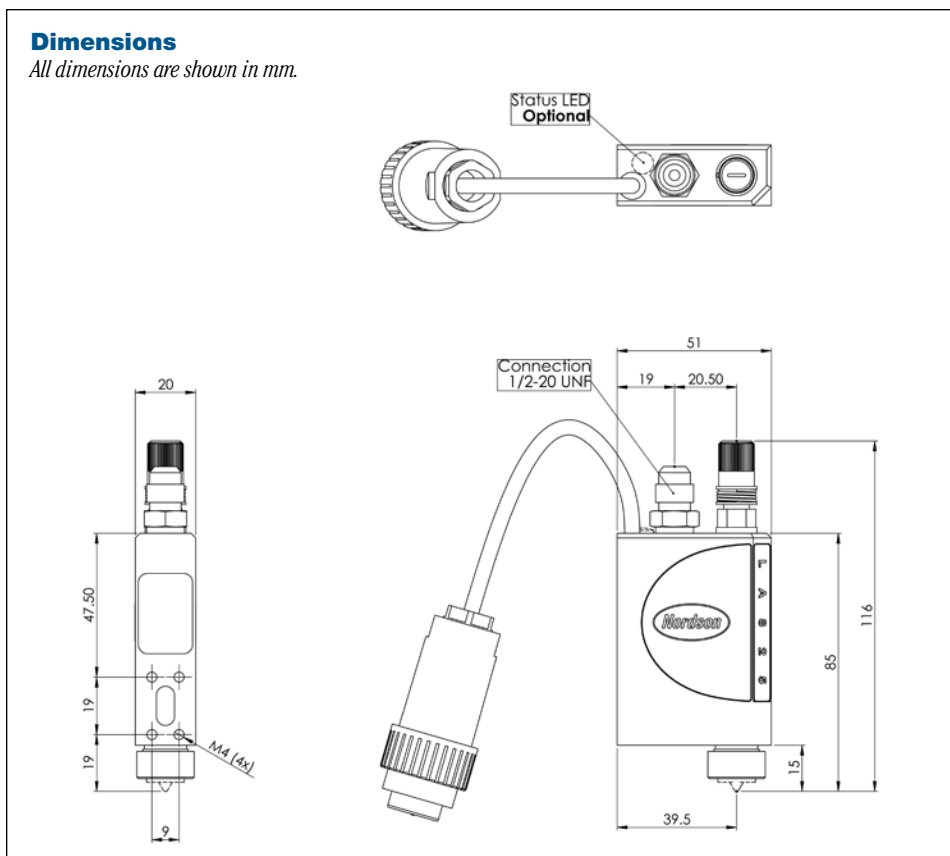

For more information, talk with your Nordson representative or contact your Nordson regional office.

United States

Duluth, Georgia

Telephone: (800) 683-2314

Facsimile: (866) 667-3329

Canada

Markham, Ontario

Telephone: (800) 463-3200

Facsimile: (905) 475-8821

Europe

Udenhout, The Netherlands

Telephone: (31) 13-511-8777

Facsimile: (31) 13-511-3995

Japan

Tokyo, Japan

Telephone: (81) 3-5762-2700

Facsimile: (81) 3-5762-2701

Asia/Australia/

Latin America

Amherst, Ohio

Telephone: (440) 985-4797

Facsimile: (440) 985-1096

www.nordson.com



When you expect more.®