



LA 310 Piston Pump Systems

Efficient pump systems provide consistent delivery of liquid adhesives and maximize production flexibility.

LA 310 piston pumps:

- Offer compact assembly on a stainless steel lid or as wall mount version for production flexibility
- Reliably provide constant adhesive pressure
- In combination with Nordson LA 380 pressure regulators, maintain consistent adhesive supply even during machine speed changes



Nordson LA 310 dual-acting piston pumps offer flexibility and consistent flow rates of liquid adhesives in folding carton, envelope, and bag and sack manufacturing. Whether lid-mount or wall-mount versions, or on Nordson’s adhesive system console, the system offers flexibility for installations in OEM machines or to retrofit existing production lines.

A 5:1 air-to-fluid ratio delivers precise application when paired with LA 380 pressure regulators. High flow rates allow use of lower pressure, reducing risk of adhesive shearing. LA 380 regulators do not need drain pipes, hoses or glue chambers to relieve glue pressure making it possible to place regulators close to the applicators.

LA 310 pumps and LA 380 pressure regulators use no Teflon® seals or parts and the lubricating oil is U.S. Food and Drug Administration approved, making the pumps acceptable for use in food and tobacco industries.

® Teflon is a registered trademark of E.I. DuPont de Nemours and Company.

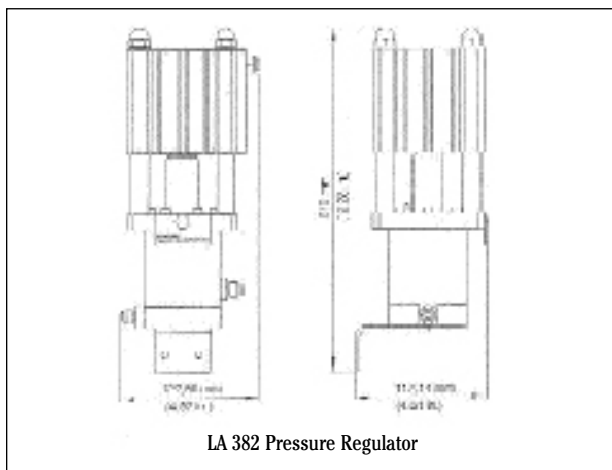

Specifications

LA 310 Piston Pumps

Maximum Pump Rate	48 l/hr (12.6 gal/hr)
Maximum Adhesive Pressure	30 bar (435 psi)
Ambient Temperature	1 to 50° C (33 to 122° F)
Air-to-fluid Pressure Ratio	5:1
Weight	11.4 kg (25 lbs) 13.3kg (29 lbs) on lid without regulator

LA 382 Pressure Regulator

Control Air Pressure	0 to 6 bar (0 to 85 psi)
Ambient Temperature	1 to 50° C (33 to 122° F)
Output Pressure Range	0 to 18 bar (0 to 250 psi)

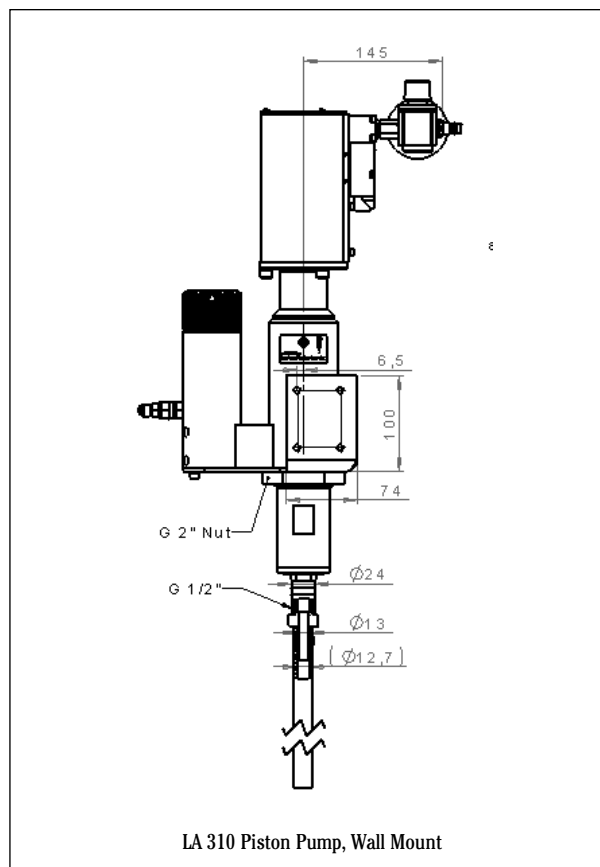
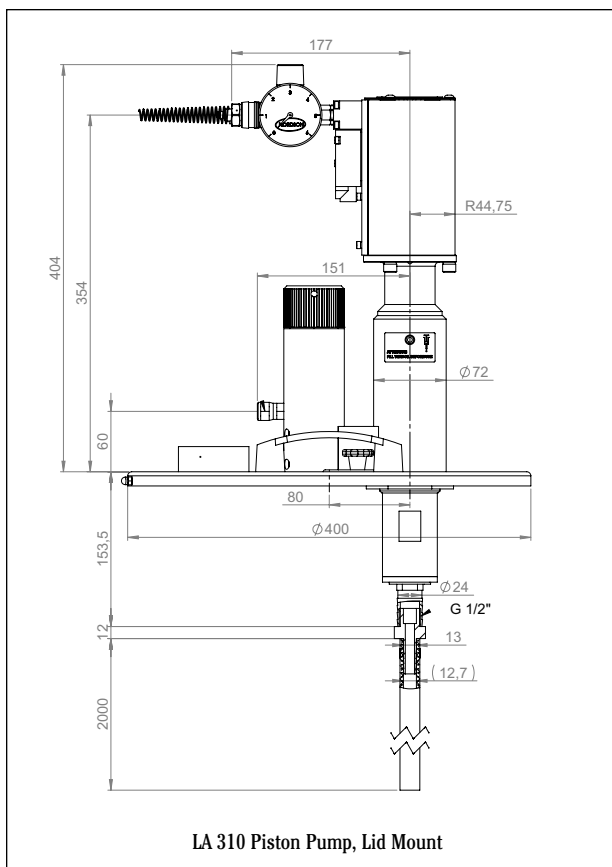

For more information, talk with your Nordson representative or contact your Nordson regional office.

United States

Duluth, Georgia
Telephone: (800) 683-2314
Facsimile: (866) 667-3329

Canada

Markham, Ontario
Telephone: (800) 463-3200
Facsimile: (905) 475-8821

Europe

Udenhout, The Netherlands
Telephone: (31) 13-511-8777
Facsimile: (31) 13-511-3995

Japan

Tokyo, Japan
Telephone: (81) 3-5762-2700
Facsimile: (81) 3-5762-2701

Asia/Australia/

Latin America
Amherst, Ohio
Telephone: (440) 985-4797
Facsimile: (440) 985-1096

www.nordson.com



When you expect more.®

Nordson Corporation • 11475 Lakefield Drive • Duluth, Georgia 30097-1511

© 2004, 2009 Nordson Corporation
All Rights Reserved.
Nordson reserves the right
to make design changes between printings.

Packaging - Processing
Bid on Equipment
1-847-683-7720
www.bid-on-equipment.com