

ClassicBlue™ Hot Melt Dispensing Guns



ClassicBlue guns and modules deliver long service life and easier maintenance.

ClassicBlue guns and modules:

- Deliver same reliable and long-life operation of Nordson H-200 guns
- Provide user-friendly design for easier and quicker maintenance
- Feature new* EasyOn™ design for faster installation

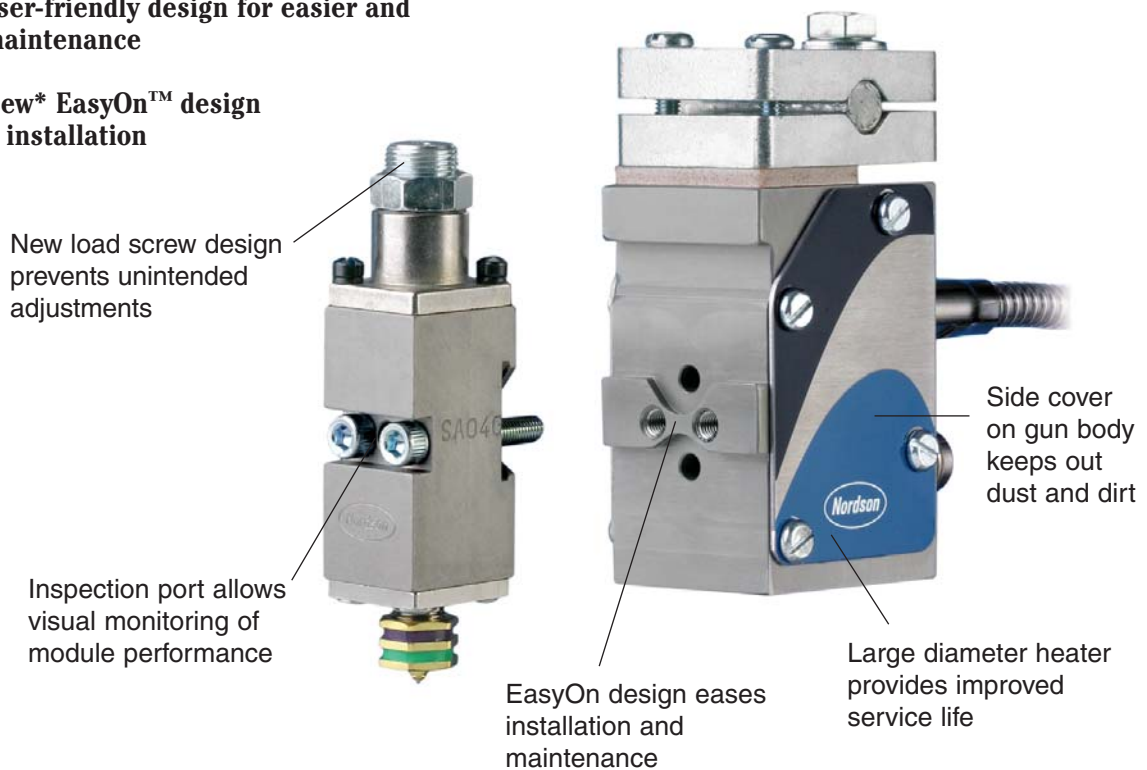

ClassicBlue guns and modules are direct replacements for Nordson H-200 series guns. Gun modules are fully rebuildable and key gun body components are easily accessible for easier, faster maintenance. All single, multi-module and special guns are built from the same gun body platform for greater application flexibility and system compatibility. The new Best Choice™ configurator allows you to quickly and easily determine the right gun body for your application, minimizing the need for specially engineered guns and reducing delivery time.

Available in three styles:

- ClassicBlue standard gun: air-open/spring-close (AO/SC) with ball and seat design
- ClassicBlue RC gun: air-open/spring-close (AO/SC) with reduced cavity needle and seat design
- ClassicBlue ZC gun: air-open/spring-close (AO/SC) with zero cavity nozzle and needle design

Unique EasyOn module mounting provides:

- Guided, one-way fit (mated module and gun body surfaces)
- Easier, safer installation (especially on gun bodies located deep within machines)
- Backward compatibility (modules fit existing Nordson gun bodies)
- Simpler design



The EasyOn mark is your assurance of genuine Nordson quality.

Packaging - Processing
Bid on Equipment
1-847-683-7720
www.bid-on-equipment.com

ClassicBlue™ Hot Melt Dispensing Guns



Nordson Saturn® solenoid valves optimize performance of ClassicBlue guns.

Specifications

Operating Temperature	450° F (230° C) maximum
Operating Air Pressure¹	40 to 70 psi (0.28 to 0.48 MPa)
Working Hydraulic Pressure	1,500 psi (10.34 MPa) maximum
Operating Speed	Exceeds 3500 cycles per minute
Integrated Nozzle Diameters²	0.008, 0.012, 0.016, 0.020, 0.032, 0.040 in. (0.2, 0.3, 0.4, 0.5, 0.8, 1.0 mm)
Saturn® Solenoid Valves³	Nordson 24 VDC Saturn high-temperature solenoids recommended
Electrical Service	240 VAC, 50/60 Hz 200 VAC, 50/60 Hz optional

Notes:

¹ Recommended range. Dry, regulated, unlubricated air required for consistent gun operation.

Module performance and durability will be negatively affected if operated outside the recommended range. Volumetric air requirements will vary with gun configuration and application.

² Nozzle diameter must be specified with gun purchase; nozzles are an integral component of the zero-cavity gun modules.

³ Nordson specifies 24 VDC Saturn high-temperature valves for pattern accuracy and extended service life

Dimensions

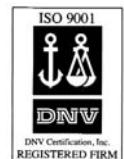
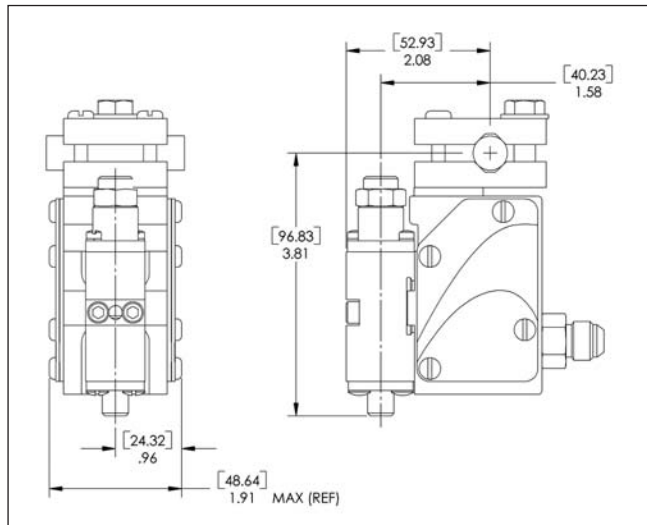

EasyOn "mated" module and gun body surfaces speed installation and maintenance.

For more information, talk with your Nordson representative or contact your Nordson regional office.

United States

Duluth, Georgia
Telephone: (800) 683-2314
Toll-free Facsimile:
(866) 667-3329

Canada

Markham, Ontario
Telephone: (800) 463-3200
Facsimile: (905) 475-8821

Europe

Lüneburg, Germany
Telephone: (49) 4131-894-0
Facsimile: (49) 4131-894-149

Japan

Tokyo, Japan
Telephone: (81) 3-5762-2700
Facsimile: (81) 3-5762-2701

Asia/Australia/ Latin America

Amherst, Ohio
Telephone: (440) 985-4797
Facsimile: (440) 985-1096

www.nordson.com



When you expect more.®

Nordson Corporation • 11475 Lakefield Drive • Duluth, Georgia 30097-1511

© 2005 Nordson Corporation
All Rights Reserved.
Nordson reserves the right
to make design changes between printings.

Packaging - Processing
Bid on Equipment
1-847-683-7720
www.bid-on-equipment.com