



BM 200 Series Bulk Melters

Highly versatile line of bulk melters to melt and dispense hot melt adhesives - designed to meet your production needs.

BM 200 bulk melters:

- **Teflon^{®1} encapsulated platen seals and finned, smooth or axial melt platens with durable ChemCoat^{®2} release coating make cleaning and maintenance easy.**
- **Microprocessor-based CS 20 control system with easy to use operator panel and 7-segment displays provides precise control of pump speed and temperatures for optimized and reproducible adhesive bonding quality.**
- **Two-hand operation required move the platen into the drums provides operator safety.**
- **Adjustable contacts "drum low" and "drum empty" notify operators to prepare for drum changes.**
- **Drum hold-downs and the automatic blow-off simplify drum changes.**
- **Pressure control valve allows to adjust the max. output adhesive pressure.**
- **Automatic run-up capability adjusts adhesive output to change in line speeds.³**
- **Parent machine interface with drum level status, pump release and alarm contacts for coordination with production machine functions.**



- ¹ Teflon is a registered trademark of E. I. DuPont de Nemours & Co.
- ² ChemCoat is a registered trademark of Impreglon GmbH.
- ³ Systems with gear pump only

With many years of worldwide experience, Nordson has designed the BM 200 bulk melter series to process hot melt adhesives, sealants, and butyls from 200 liter or 55 gallon drums. The host of standard features of the BM 200 bulk melters and a wide range of options and field-installable accessory kits provide you with high application flexibility, reliable performance, and easy and safe operation.

BM 200 bulk melters melt the adhesive on the surface of the drum only, allowing the remaining material in the drum to stay cool. This reduces thermal stress on temperature sensitive adhesive and protects the bonding characteristics.

Melt platens are available with three surfaces: the axial structure, the finned structure (offers high melt rates) and the smooth surface (ideally suited for the processing of moisture curing

polyurethane (PUR) hot melts). All platens are coated with a durable ChemCoat[®] release coating for easy cleaning. A variety of pump selections, ranging from gear pumps to high-volume piston pumps, allows the user to customize BM 200 bulk melters to meet individual application needs and adhesive properties.

Reliable operation and extensive process control is provided by the proven Nordson microprocessor-based control system CS 20. Features include sequential startup, programmable over and under temperature alarms, temperature setback and automatic diagnostics.

For high volume applications, you can specify Nordson's automatic change-over system. By linking two separate bulk melters together, it provides continuous operation and eliminates the downtime associated with pallet changes.

BM 200 Series Bulk Melters

Options

- Output pressure control maintains the hydraulic pressure at a constant, programmable level.
- Profibus interface allows seamless integration into the control system (PLC) of the production machine; for statistical process control / data logging, remote control of all functions or visualization of process data.
- Additional temperature channels for use with spray guns, air heaters, or other additional devices that need accurate temperature control.
- Metal jacket allows to process adhesive in fiber drums.
- Pallet load frame allows to position adhesive drums on pallets using fork lifts easily. During production, drums stay on pallet.
- Two hose version allows to supply two independent applications from one single bulk melter. To further ensure constant output, the pump speed increases automatically when the second gun is opened.

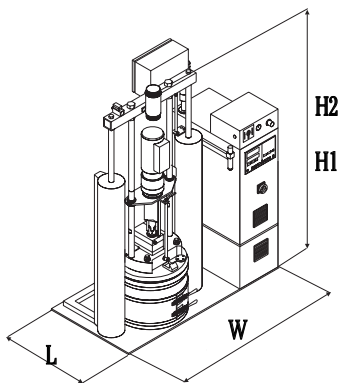

Dimensions

| | |
|------------|---------------------------------------|
| L | 800 mm / 31.5 in. |
| W | 1630 mm / 64.2 in. |
| H 1 | 1730 mm / 68.1 in. (melt platen down) |
| H 2 | 2720 mm / 107.1 in. (melt platen up) |

Accessories

- Warning light tower allows seeing the status of the unit (on; ready; drum low/empty; fault) from a distance.
- Seven-day timer automatically heats up the system at programmable times, ensuring the adhesive is ready at the beginning of the production shift.
- Exhaust hood connects to factory ventilation, drawing fumes and smoke away from operator during drum changes.
- Automatic changeover controller allows to fully integrate two stand-alone BM 200 drum melters into a continuous operating changeover system - avoiding production stops caused by empty drums.
- External transformer kit for 200 / 240 VAC mains supply voltage.

Finned high-melt platen



Smooth platen



Axial platen

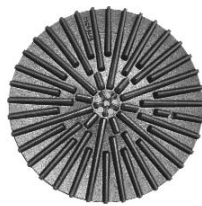

Piston pump unit - the solution for high viscosity adhesives.

Specifications

| | |
|-----------------------------|---|
| Weight | approx. 730 kg / 1610 lb |
| Voltage | 400, 480 VAC; optional 200, 240 VAC 3phase; 50/60 Hz |
| Wattage⁴ | 31 kW |
| Drum Diameter | 571 mm / 22.5 in. |
| Temperature Sensor | Ni 120 |
| Degree of Protection | IP54 |

⁴ Base unit with gear pump for one hose /gun

For more information, talk with your Nordson representative or contact your Nordson regional office.

| | | | | |
|---|---|--|--|--|
| United States Duluth, Georgia Telephone: (800) 683-2314 Facsimile: (866) 667-3329 | Canada Markham, Ontario Telephone: (800) 463-3200 Facsimile: (905) 475-8821 | Europe Lüneburg, Germany Telephone: (49) 4131-894-0 Facsimile: (49) 4131-894-149 | Japan Tokyo, Japan Telephone: (81) 3-5762-2700 Facsimile: (81) 3-5762-2701 | Asia/Australia/ Latin America Amherst, Ohio Tel. (440) 985-4797 Fax (440) 985-1096 |
|---|---|--|--|--|

© 2001 Nordson Corporation
All Rights Reserved
Nordson reserves the right
to make design changes between printings.



Packaging - Processing
Bid on Equipment
1-847-683-7720
www.bid-on-equipment.com