



# Single Head Capping System Model: NESHC



Model NESHC Single Head Capping System (index shuttles)



Close-up of capping area

The New England Machinery, Inc. NESHC is a continuous motion single head capping system with a highly accurate indexing turret. Its unique design allows for use with a wide variety of caps and containers. The NESHC's highly accurate cap placement offers positive chuck cap application for straight and secure caps.

**Versatility** – The NESHC is a freestanding unit capable of being placed over an existing customer-supplied continuous motion conveyor. This capper offers tool-less, easy changeover modular change parts. Child resistant cap features are available.



Single Head Capping System with optional servo head

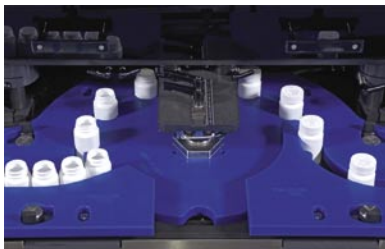

Close-up of capping area

**Dependability** – The design of the NESHC allows the chuck to rotate to the desired application torque and releases the cap, preventing cap or thread damage due to over-torquing.

**Accuracy** – NEM's new electronic torque control offers consistent and repeatable applied torque.

**Gentle Handling** – The NESHC offers non-scuff chucks for gentle, positive grip, higher speeds and throughput.

**Servo Option** – The NESHC is available with Servo motors. This option allows positive applied torque control through dial-in torque settings. The closed loop system gives feedback to the operator. Utilizing a programmable electronic cam (which can set up and store container and cap parameters) this option will send data to the controller memory. The values can be recalled via recipe selection from the HMI.

## NESHC Snapshot:

- Tubular 304 stainless steel welded frame
- Easy changeover modular change parts
- Soft start and stop features
- Jog switch w/10 foot cord
- Non-scuff collets for gentle, positive grip
- No tools quick change collet
- Torque adjustable w/o the use of tools and w/o line stoppage
- Clear acrylic guard w/stainless steel lower frame cover
- Safety interlocks on all guard doors
- Adjustable discharge height 36" ± 2"
- High floor clearance
- Smoothed and polished welds
- Operations and maintenance manual
- Direct discharge to customer's constant speed, continuous motion, non-stopping conveyor
- Low air safety shutdown
- UL listed components

**New England Machinery, Inc.**

*Innovators In Container Handling Systems . . . . .*



## NESHC Specifications

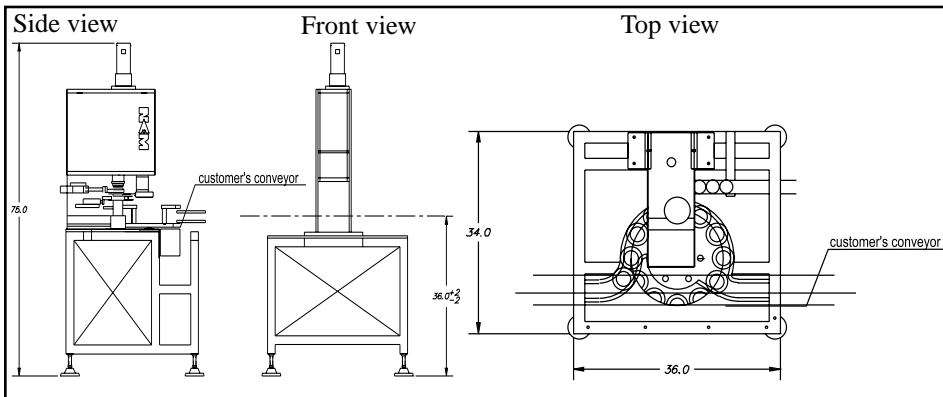

NESHC Single Head Capping System (starwheel)



Close-up of capping area

### Optional Equipment

- Servo motors
- Anodized aluminum
- Change from std. (36"± 2") discharge height
- Cluster central lubrication for hopper elevator
- Nitrogen purging
- Servo motors
- Additional emergency "E" stop(s)
- HMI (human machine interface)
- Heavy duty lockable caster wheels
- Extended range for oversized containers
- Left-hand discharge
- Minimum tools quick change feature
- Machine status (four light post) with annunciator
- Missing cap/lid detector/container rejecter
- Low cap/lid level warning
- NEMA-4 (wash down) or NEMA-7 (explosion proof) electrical
- 50 Hz or other special power requirement
- PLC upgrades
- Digital container counter (bottles per minute)
- Spare parts kit
- Torque adjustable without the use of tools
- Jam detection package
- Integrated torque testing system
- Upgrade to polycarbonate guarding

### ELECTRICAL FEATURES

- NEMA-12 electrical
- 220 volt, single phase, 60Hz input requiring 20 amp service
- Backlog photo-eye w/automatic stop and restart
- Allen-Bradley® PLC
- TEFC (totally enclosed fan cooled) AC motors
- AC drives

### PNEUMATICS

- 5-20 cfm. @ 80 psi. clean, dry, oil-free compressed air

### BENEFITS

- Accurate and repeatable applied torque
- Easy changeover
- Smooth, safe cap handling - no burning or marring
- Accurately aligned placement of cap
- No clutch wear parts
- Capable of handling up to 120 mm CT and CR caps

### SERVO OPTION BENEFITS

- Supports the flexibility of recipe-driven format changes and torque control
- The ability to sense and reject mis-torqued caps
- Document applied torque values

NESHC single head capper can be configured to customer specification, upon request.

## New England Machinery, Inc.

2820 62nd Ave East, Bradenton, FL 34203 U.S.A.

941/755-5550 Fax: 941/751-6281

www.neminc.com

E-mail: info@neminc.com

Changes in machine design or specifications are a result of continuous machine improvements and New England Machinery, Inc. reserves the right to change standard specifications without prior notice. The above illustration(s) and text are representative in scope only.  
 NESHC 02/08