

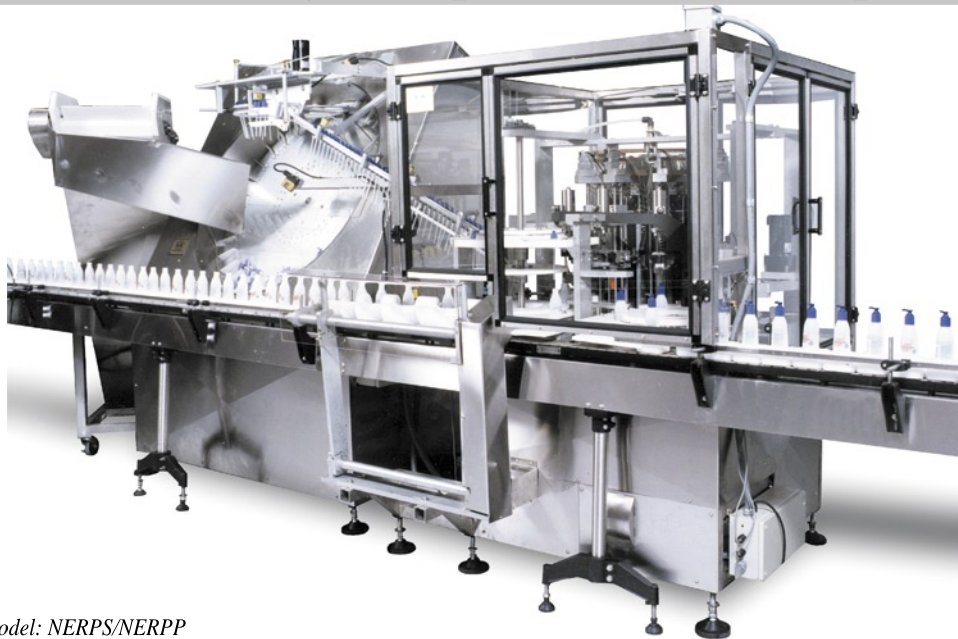

Rotary Pump Sorter and Pump Placer



Model: *NERPS/NERPP*



Close-up of pump placer area

The New England Machinery, Inc. *NERPS/NERPP* is a highly effective, yet competitively priced system for sorting, feeding and placing product pumps into filled containers. This system consists of a bulk supply hopper/elevator, pump sorter/feeder/placer and tightener for lotion, finger and trigger pump assemblies.

Dependability – Pump tubes are accurately guided into the container. An *NEPMT* retorquer (sold separately) accurately applies the final torque to the containers and sends them downstream on the customer's continuous motion conveyor.

Gentle Container Handling – The *NERPS/NERPP* gently handles even delicate or pre-decorated containers safely.

Speed – The *NERPS/NERPP* offers the fastest speeds in the industry at a competitive price.



The NERPS/NERPP is able to handle several types of pumps

NERPP Snapshot:

- Tubular 304 stainless steel welded frame
- Anodized aluminum and 304 stainless steel construction
- Soft start and stop features
- Clean, non-painted, non-marring surfaces
- Precision aluminum faceplate
- Jog switch w/ 10 foot cord
- Clear acrylic guard w/ stainless steel lower frame cover
- Adjustable discharge height 36" ± 2"
- High floor clearance
- Smoothed & polished welds
- Direct discharge to customer's constant speed, continuous motion conveyor
- Operations and maintenance manual
- UL listed components

New England Machinery, Inc.
Innovators In Container Handling Systems

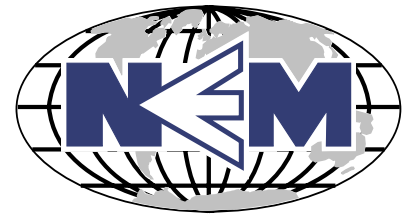

NERPS/NERPP Specifications

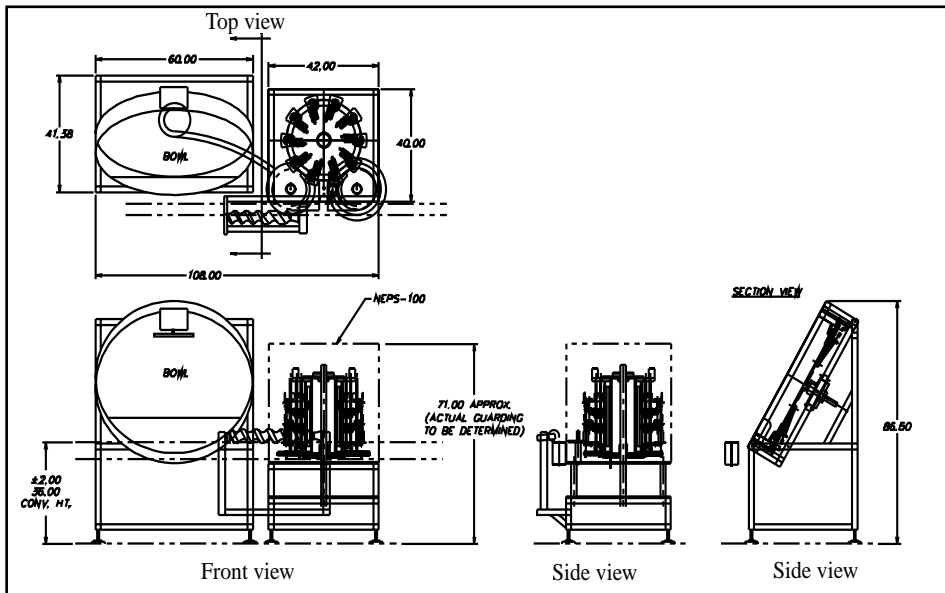

The pump sorter area

ELECTRICAL FEATURES

- NEMA-12 electrical
- 220 volt, single phase, 60Hz input requiring 30 amp service
- Backlog photo eye w/automatic stop and restart
- TEFC (totally enclosed fan cooled) AC motors
- AC inverter drives
- Integral electrical enclosure
- Allen Bradley® Micro Logix 1000 PLC

PNEUMATICS

- 5-10 cfm. @ 80 psi. clean, dry compressed air

NERPS and NERPP can be configured to any customer specification, upon request.

New England Machinery, Inc.

2820 62nd Ave East, Bradenton, FL 34203 U.S.A.

941/755-5550 Fax: 941/751-6281

www.neminc.com

E-mail: info@neminc.com

Optional Equipment

- PLC upgrade
- NEMPT Retorquer for cap tightening
- Feeder for trigger pumps
- NEMA-4 (washdown) or NEMA-7 (explosion proof) electrical
- Puck system for difficult/unusual-shaped containers
- Change from standard (36" ± 2") discharge height
- Central lubrication
- Digital container counter (cpm or cumulative)
- Left-hand discharge
- Polycarbonate guarding
- Extra operation and maintenance manuals
- Machine status (four light post with annunciator)
- Additional emergency "E" stop
- Feeder for lotion pumps
- HMI