

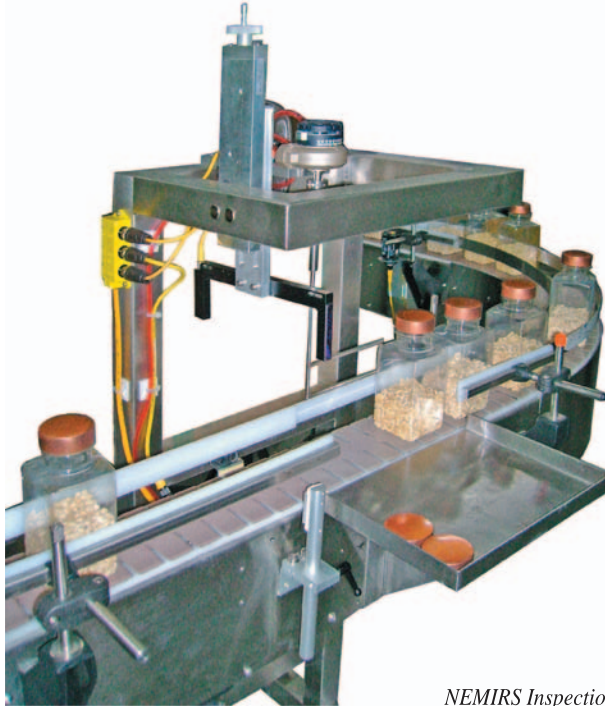

Inspection Rejection System

Model: NEMIRS



*NEMIRS Inspection/Rejection System
(Shown without guarding)*

Versatile – The NEMIRS is a stand-alone inspection, rejection system. It can inspect for skewed caps, missing caps or liners (foil only). It can detect down bottles or mis-oriented bottles. Depending on the inspection requirement, it can utilize simple photo eyes, proximity switches, limit switches, or vision system. The containers can be rejected using an air blowoff, diverter arm, or pusher cylinder. The rejects can be rejected to a table, collected in a bin, or transferred to an existing system.

Fast – The NEMIRS can keep up with the speed of the customer's production line and is adjustable for different line speeds up to 450 cpm depending on container size and the inspection requirement.

Compact Design – The NEMIRS is a self-contained, freestanding unit. Operators have easy access for collecting rejects and changing settings.

NEMIRS Snapshot:

- Tubular 304 stainless steel welded frame
- Anodized aluminum and 304 stainless steel construction
- Clean, on-painted, non-marring surfaces
- Adjustable inspection and discharge height 36" ± 2"
- High floor clearance
- Smoothed and polished welds
- One operations & maintenance manual (CD)
- NEMA 12 electric

New England Machinery, Inc.

Innovators In Container Handling Systems



NEMIRS Specifications

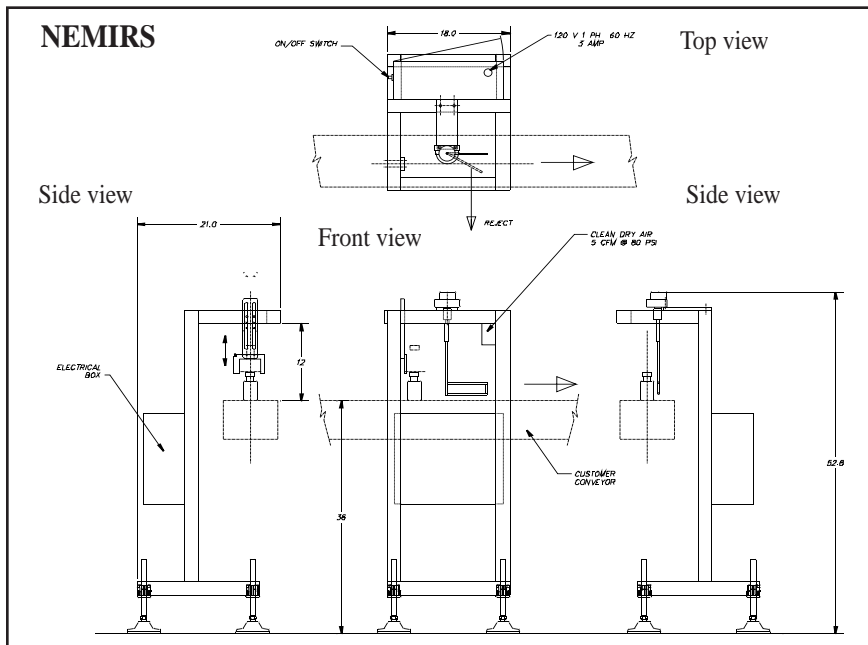

BENEFITS

- Compact Design
- Easy Installation – Over Customer's Conveyor
- Low Maintenance
- Versatile for Various Applications

ELECTRICAL FEATURES

- NEMA-12 Electrical
- 120 VAC, 60Hz Input Requiring 3 Amp Svc.

PNEUMATICS

- 0-5 cfm @ 80 psi clean, dry, oil free compressed air (depending on application)

NEMIRS inspection rejection system can be configured to customer specifications, upon request.

New England Machinery, Inc.

2820 62nd Ave East, Bradenton, FL 34203 U.S.A.

941/755-5550 Fax: 941/751-6281

www.neminc.com

E-mail: info@neminc.com

Changes in machine design or specifications are a result of continuous machine improvements and New England Machinery, Inc. reserves the right to change standard specifications without prior notice. The above illustration(s) and text are representative in scope only.

NEMIRS 05/10

Optional Equipment

- Heavy duty lockable caster wheels
- Change from Std. (36" +/-2") inspection/discharge height
- Digital container counter (bottles per minute)
- Left hand discharge
- Optional washdown NEMA 4 electric
- Stainless steel construction
- HMI
- Upgrade machine guarding to polycarbonate
- Data collection
- Extra operation and maintenance manual (hard copy)
- Rejection confirmation