

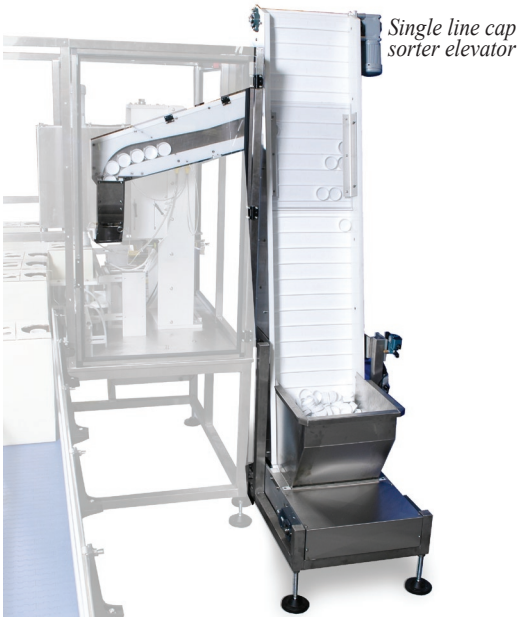

Cap/Lid Sorter

Model: NECS



NECS Snapshot:

- Designed for feeding caps, parts, plugs, tips, lids, etc.
- All contact surfaces 304 stainless steel or FDA approved plastic
- Custom hopper sizes, elevator lengths and delivery systems available
- Photo electric monitoring
- Clean, non-painted, non-marring surfaces
- Smoothed and polished welds
- Clear acrylic guarding
- UL listed components
- Floor level loading

The New England Machinery Model NECS Cap/Lid Sorter sorts and feeds caps to a capper via a cap chute. This model uses either a sorter bowl or Hopper Elevator to sort the caps. The Hopper Elevator method comes in both single and dual belt systems. The single belt can be adjusted for several cap sizes. The dual belt allows a wide variety of cap sizes without belt changeover.

Easy to use – The NECS design is operator friendly. The hopper is positioned low for easy filling and cap level monitoring. The high floor clearance gives you easy access for quick cleaning. Slower or faster speeds can be obtained through VFD variable speed controls.

Easy to adjust – The NECS can be simply adjusted to switch to a new cap size.

Safe for components – Standard stainless steel bin and elevator construction provides components with clean non-painted contact surfaces as they are transported.

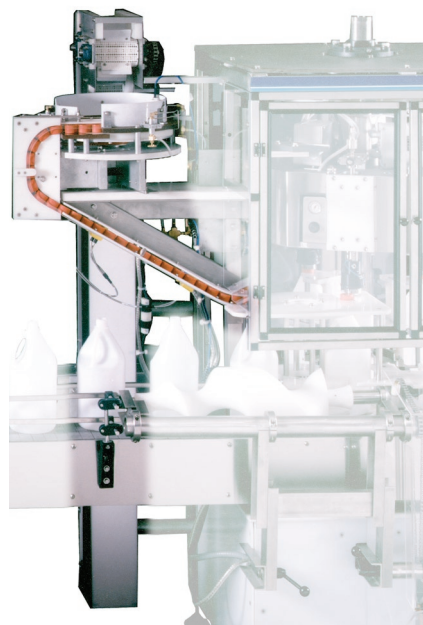

Cap sorter with sorter bowl

New England Machinery, Inc.

Innovators In Container Handling Systems



Cap/Lid Sorter Specifications

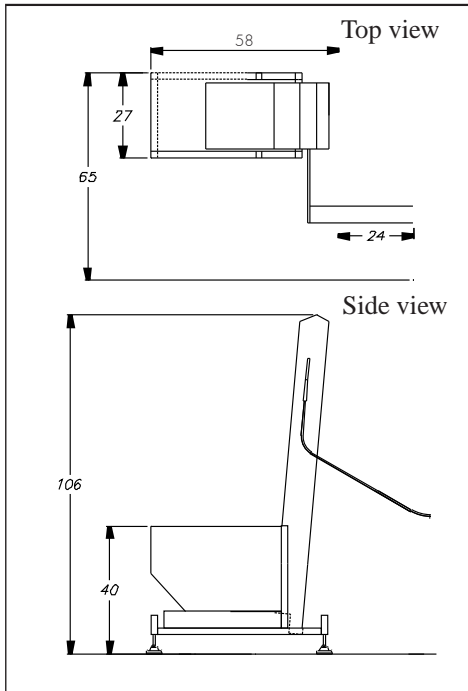

Single line cap sorter elevator

Optional Equipment

- Full covers
- Light stack for machine status with annunciator
- Pharmaceutical and food grade finishes
- Polycarbonate covers
- Noise reduction
- Integrate with existing capping system



Single line cap sorter elevator



Lid sorter bowl with elevator

ELECTRICAL FEATURES

- NEMA-12 electrical
- 220 volt, single phase, 60 Hz, input requiring 15 amp service
- AC variable frequency drives

NECS can be configured to any customer specification, upon request.

New England Machinery, Inc.
 2820 62nd Ave East, Bradenton, FL 34203 U.S.A.
 941/755-5550 Fax: 941/751-6281
 www.neminc.com E-mail: info@neminc.com



Our sorters are capable of handling a wide range of caps and lids