



Low Profile Unscrambler

Model: LP-36



LP-36 Low Profile Unscrambler

Versatility - This low profile design is ideal for pharmaceutical, nutraceutical, personal care products and hospitality style amenities. Designed to handle containers up to 3" in diameter and 6" high, this system is ideally suited for unscrambling small, delicate straight-walled, round, oval and square containers. This affordable system requires minimal floor space.



Side view of the bowl

Gentle Handling - The use of padded belt transfer systems augments the gentle handling characteristics of the LP-36 to eliminate opportunities for container scuffing or other damage. Even delicate, pre-decorated containers are fully protected throughout the workflow.

Dependability - The LP-36's new dual motor drive system minimizes the number of drive components, eliminates particulate-causing gear belts, and allows easier changeover.

Speed - The unique design of the LP-36 allows it to achieve the highest speeds available in the industry. Depending on container size and configuration, it can reach speeds up to 450 containers per minute.

Ease of Use - The LP-36 is ergonomically designed. The low profile design is easy to load without lifting or climbing. All functions – container bulk supply, sorter bowl, and orienting workflow – are positioned at eye level, making the entire machine accessible for container loading, changeover, or maintenance. A single line operator can perform changeovers in fifteen minutes or less from the floor.

LP-36 Snapshot:

- Tubular 304 stainless steel welded frame
- Powder coated aluminum faceplate
- Clean, non-painted, non-marring surfaces
- Smoothed and polished welds
- Clear acrylic hinged guarding doors
- Safety interlocks on all guard doors
- Non-scuffing nylon faced padded transfer belts
- Easy changeover modular change parts
- Soft start and stop features
- Jog switch w/ 10 foot cord
- Adjustable discharge height 36" ± 2"
- High floor clearance
- Operations and maintenance manual
- Clear acrylic 36" bowl cover
- UL listed components

New England Machinery, Inc.

Innovators In Container Handling Systems

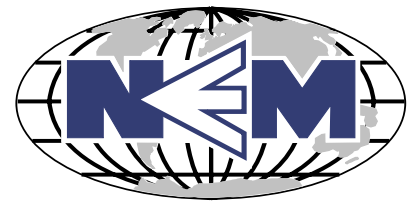

LP-36 Specifications

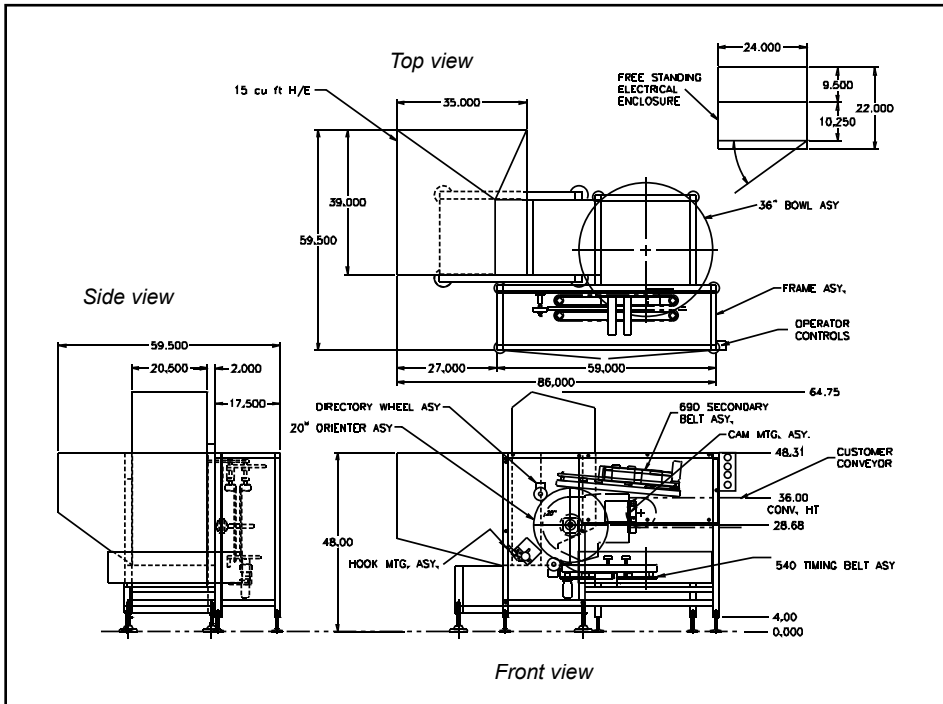

ELECTRICAL FEATURES

- NEMA-12 electrical
- 220 volt, single phase, 60Hz input requiring 30 amp service
- Allen-Bradley® Micro Logix 1000 PLC
- Backlog photo-eye w/automatic stop & restart
- AC variable frequency drives
- Remote electrical enclosure

PNEUMATICS

- 5-10 cfm. @ 80 psi. clean, dry compressed air



Handles most container configurations

Optional Equipment

- Anodized aluminum
- Caster wheels on elevator and unscrambler
- Change from std. (36" +/-2") discharge height
- Central lubrication
- Digital container counter
- Extended range for oversized containers
- Horizontal (decorating) discharge
- Jam detector (overload)
- Left-hand discharge
- Minimum tools quick change feature
- Sound reduction package
- Upgrade machine guarding to polycarbonate
- Clear polycarbonate 36" bowl cover
- Larger hopper/elevator
- HMI
- PLC upgrade
- Light post for machine status with annunciator

LP-36 Unscrambler can be configured to any customer specification, upon request.

New England Machinery, Inc.
 2820 62nd Ave East, Bradenton, FL 34203 U.S.A.
 941/755-5550 Fax: 941/751-6281
 www.neminc.com E-mail: info@neminc.com