



MHWW-36-H-1 Chilled/Hot Water Hi-Wall Fan Coil

2-Pipe Heat / Cool Fan Coil 36,000 BTUH

MHWW NOMENCLATURE BREAKDOWN

2-Pipe Heat/Cool Hi-Wall Fan Coil

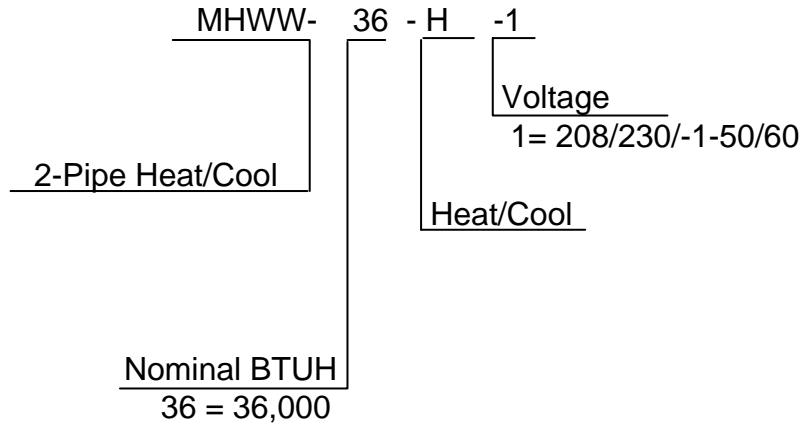

Available Model Numbers

MHWW-36-H-1

HVAC Guide Specifications

Chilled and Hot Water Hi-Wall Fan Coil
2-Pipe

Nominal Size:

36,000 BTUH

MultiAqua Model Number:

MHWW-36-H-1

Part 1-General

1.01 System Description

MultiAqua Chilled Water Fan Coils are manufactured with high impact molded polymers.

1.02 Quality Assurance

- A. Certified in accordance with U.L. Standard 95, latest version (U.S.A.)
- B. Manufactured in a facility registered to ISO 9002, Manufacturing Quality Standard.
- C. Fully load tested at the factory.
- D. Damage resistant packaging.

1.03 Delivery, Storage and Handling

- A. Packaged and readied for shipment from the factory.
- B. Controls shall be capable of withstanding 150°F storage temperatures in the control compartment.
- C. Stored and handled per manufacturer's recommendations.

Part 2-Product

2.01 Equipment

- A. General:
 1. Unit shall be a factory assembled and tested chilled and hot water fan coil.
 2. Shall be assembled with high quality.
 3. Contained with the unit shall be all factory wiring, piping, associated controls and special accessories required prior to start up.
- B. Unit Cabinet:
 1. Composed of high impact polymers.
 2. Shall be internally insulated to insure quiet operation.
- C. Fan Motors:
 1. Shall be available in 208/230-1-50/60 vac.
 1. Fan motors shall be three speed, direct drive, and PSC type.
 2. Totally enclosed.
 3. Internal overload protected.
 4. Unit shall contain a swing motor to modulate the discharge air.
- D. Blower Wheels:
 1. Blower wheels are tangential and dynamically balanced.
- E. Water Coil:
 1. Manufactured with water coils containing 3/8" copper tubing mechanically bonded to aluminum fins.
 2. Coils shall be factory tested to 350 psig.
- F. Drain Pan:
 1. All drain pans shall be molded with high impact polymers.
 2. The exterior of all drain pans shall be insulated with closed cell to prevent condensation.
 3. Pans shall contain a flexible drain tubing that is accessible from the back of the unit.
- G. Filters:
 1. Unit shall contain 65% washable filters.

Part 3-Controls and Safeties**3.01 Controls**

- A. Fan coils shall be completely factory wired and tested.
- B. Controls shall include a circuit board, room sensor, indoor coil thermistor, transformer and wireless remote.
- C. Controls are capable of incorporating an optional Multiagua hard-wired thermostat.
- D. Controls shall be capable of controlling the 2-pipe fan coil on a 4-pipe hydronic system. Contact factory for piping and wiring layouts.

3.02 Safeties:

- A. Fan coil shall contain a non reusable fuse on the secondary voltage side of the transformer.
- B. Discharge air sensor.

Part 4-Operating Characteristics:**4.01 Electrical Requirements**

- A. Unit shall incorporate a three prong male primary electrical power cord.
- B. Electrical power supply shall be rated to withstand 120°F operating ambient temperatures.

MHWW-36-H-1 Product Specifications

Physical Data									
Model Number	Height (in)	Length (in)	Depth (in)	Weight (lbs)	Cooling Rows FPI	Copper Diameter (in)	Water Inlet (in)	Water Outlet (in)	Drain (in)
MHWW-36-H-1	14.25	56.50	8.37	50.50	3-18	3/8	3/4	3/4	3/4

Electrical Data						
Model Number	Hi Speed CFM	Volts/ Phase/ Hertz	Motor HP	Full Load Ampacity	Fuse or HACR Circuit Breaker Per Circuit	
					Minimum Amps	Maximum Amps
MHWW-36-H-01	850	208/230-1-50/60	1/12	0.42	.53	1

These specifications are subject to change without notice.

MHWW-36-H-1 Chilled Water Performance Data

MHWW-36 COOLING CAPACITIES					
CFM	EWT (°F)	GPM	ENTERING AIR TEMPERATURE (°F)		
				80° D.B. / 67° W.B.	75° D.B. / 63° W.B.
850	42	7.2	TC	33.8	25.9
			SC	24.6	21.6
			WPD	11.8	11.8
		8.0	TC	34.6	26.5
			SC	24.8	21.8
			WPD	13.7	13.7
		9.0	TC	35.4	27.0
			SC	25.1	22.0
			WPD	15.8	15.8
		10.0	TC	36.0	27.5
			SC	25.4	22.2
			WPD	17.9	17.9

MHWW-36 COOLING CAPACITIES					
CFM	EWT (°F)	GPM	ENTERING AIR TEMPERATURE (°F)		
				80° D.B. / 67° W.B.	75° D.B. / 63° W.B.
850	45	7.2	TC	31.1	23.7
			SC	23.5	20.8
			WPD	11.8	11.8
		8.0	TC	31.8	24.3
			SC	23.8	21.0
			WPD	13.7	13.7
		9.0	TC	32.4	24.8
			SC	24.0	21.2
			WPD	15.8	15.8
		10.0	TC	33.0	25.2
			SC	24.3	21.3
			WPD	17.9	17.9

These specifications are subject to change without notice.

MHWW-36-H-1 Hot Water Performance Data

MHWW-36 HEATING CAPACITIES														
ENTERING AIR (°F)	CFM	GPM	WPD	ENTERING WATER TEMPERATURE (°F)										
				100°	110°	120°	130°	140°	150°	160°	170°	180°	190°	200°
50	850	7.0	11.8	39.7	47.7	55.6	63.6	71.5	79.5	87.4	95.4	103.3	111.3	119.2
		8.0	13.7	40.1	48.1	56.2	64.2	72.2	80.2	88.3	96.3	104.3	112.3	120.3
		9.0	15.8	40.5	48.5	56.6	64.7	72.8	80.9	89.0	97.1	105.2	113.3	121.4
		10.0	17.9	40.8	48.9	57.1	65.2	73.4	81.5	89.7	97.8	106.0	114.1	122.3

MHWW-36 HEATING CAPACITIES														
ENTERING AIR (°F)	CFM	GPM	WPD	ENTERING WATER TEMPERATURE (°F)										
				100°	110°	120°	130°	140°	150°	160°	170°	180°	190°	200°
60	850	7.0	11.8	31.8	39.7	47.7	55.6	63.6	71.5	79.5	87.4	95.4	103.3	111.3
		8.0	13.7	32.1	40.1	48.1	56.2	64.2	72.2	80.2	88.3	96.3	104.3	112.3
		9.0	15.8	32.4	40.5	48.5	56.6	64.7	72.8	80.9	89.0	97.1	105.2	113.3
		10.0	17.9	32.6	40.8	48.9	57.1	65.2	73.4	81.5	89.7	97.8	106.0	114.1

MHWW-36 HEATING CAPACITIES														
ENTERING AIR (°F)	CFM	GPM	WPD	ENTERING WATER TEMPERATURE (°F)										
				100°	110°	120°	130°	140°	150°	160°	170°	180°	190°	200°
70	850	7.0	11.8	23.8	31.8	39.7	47.7	55.6	63.6	71.5	79.5	87.4	95.4	103.3
		8.0	13.7	24.1	32.1	40.1	48.1	56.2	64.2	72.2	80.2	88.3	96.3	104.3
		9.0	15.8	24.3	32.4	40.5	48.5	56.6	64.7	72.8	80.9	89.0	97.1	105.2
		10.0	17.9	24.5	32.6	40.8	48.9	57.1	65.2	73.4	81.5	89.7	97.8	106.0

MHWW-36 HEATING CAPACITIES														
ENTERING AIR (°F)	CFM	GPM	WPD	ENTERING WATER TEMPERATURE (°F)										
				100°	110°	120°	130°	140°	150°	160°	170°	180°	190°	200°
80	850	7.0	11.8	15.9	23.8	31.8	39.7	47.7	55.6	63.6	71.5	79.5	87.4	95.4
		8.0	13.7	16.0	24.1	32.1	40.1	48.1	56.2	64.2	72.2	80.2	88.3	96.3
		9.0	15.8	16.2	24.3	32.4	40.5	48.5	56.6	64.7	72.8	80.9	89.0	97.1
		10.0	17.9	16.3	24.5	32.6	40.8	48.9	57.1	65.2	73.4	81.5	89.7	97.8

These specifications are subject to change without notice.

MHWW-36-H-1 Capacity and Glycol Adjustments

CAPACITY CORRECTION FACTORS

MODEL #	MHWW-36-H-1	
CFM	TC	SC
675	.82	.80
700	.85	.82
750	.91	.88
825	.98	.95

Propylene Glycol & GPM Adjustment Factors			
Ambient Temp	Propylene Glycol %	Capacity Reduction	GPM Adjustment = 100% Capacity
26° F	10%	x 0.99	x 1.01
20° F	20%	x 0.98	x 1.03
8° F	30%	x 0.98	x 1.07
-5° F	40%	x 0.97	x 1.11
-28° F	50%	x 0.96	x 1.16

Example:
 30% Propylene Glycol Solution.
 System capacity x 0.98
 GPM x 1.07



INSTALLATION & OPERATING MANUAL

MHWW Hi-Wall Fan Coils
36,000 BTUH

MHWW CONTROLS OPERATION GUIDE

Wireless Control: Standard Control Package



Optional Wired Control: EG-003





INSTALLATION & OPERATING MANUAL

MHWW Hi-Wall Fan Coils
36,000 BTUH

MHWW CONTROLS OPERATION GUIDE

Wireless Control:

Name and function of remote controller

Note:

- Be sure there are no obstructions between receiver and remote controller.
- The remote control signal can be received at the distance of up to about 21 feet.
- Do not throw or drop the remote controller.
- Do not put any liquid in the remote controller and do not put it in direct sunlight or any place where it is very hot.
- Remove batteries when the remote controller is not in use for extended periods of time.
- The remote controller should be placed 3 or more feet away from any electric appliance.

LED MODE INDICATOR FOR REMOTE CONTROLLER:

INDICATOR LIGHTS	REMOTE SETTING	FUNCTION
RED-GREEN	COOL	COOLING OPERATION ONLY
RED-OFF	DRY	HUMIDITY CONTROL, WATER FLOW, NO FAN
RED-RED	HEAT	HEATING OPERATION ONLY
RED-OFF	FAN	FAN OPERATION ONLY
RED-BLINKING	AUTO	AUTO SELECTION BETWEEN HEAT & COOL DEPENDENT ON ROOM TEMP & SET TEMP
RED-ORANGE	ALERT	FAN COIL WAITING FOR EWT TO REACH PROPER TEMPERATURE NECESSARY TO SATISFY SET POINT



INSTALLATION & OPERATING MANUAL

MHWW Hi-Wall Fan Coils
36,000 BTUH

MHWW CONTROLS OPERATION GUIDE

FUNCTION

1. TRANSMISSION SOURCE

- Infra red transmission source

2. POWER

- Press to turn the fan coil on and off or vice versa.
(Red LED left will light to indicate the control is on)

3. MODE

- To select desired operation mode.

It will switch from one to another as shown.

COOL - Cooling operation.

DRY - Humidity control.

HEAT - Heating operation.

FAN - Fan only. No cooling or heating capability.

AUTO - Operation mode will be selected automatically between HEAT and COOL mode, depending upon the room temperature and SET temperature.

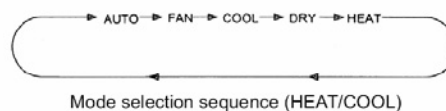
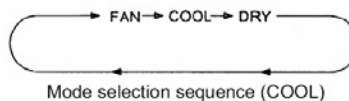

4. FAN

- To select fan speed. It will switch from one to another as shown below.

- When the system temperature sensor is not calling for cool or heat the fan will run at the speed previously entered in fan mode selection (high, medium or low).

- If auto was the previously entered fan speed in cooling: The fan will run at low speed until the temperature sensor calls for either heating or cooling at which point the fan will return to auto speed control

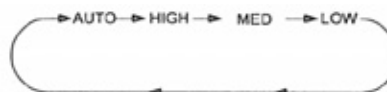

Fan speed sequence



INSTALLATION & OPERATING MANUAL

MHWW Hi-Wall Fan Coils
36,000 BTUH

MHWW CONTROLS OPERATION GUIDE

FUNCTION

5. TEMPERATURE SETTING

- Press “▲” to increase set temperature.
- Press “▼” to decrease set temperature.
- Press “▲” and “▼” Simultaneously to toggle between °C and °F display mode.
- Temperature range: 16°C to 30°C in °C display mode and 60°F to 86°F in °F display mode.

(a) °C display mode

(b) °F display mode

6. DELAY TIMER SETTING

- The delay timer is capable of delaying both on and off functions. The delay feature will take affect in all modes with the exception of the sleep mode. Each time the “▲” and “▼” is pressed it increases or decreases the On or OFF set point by 1 hour; up to a maximum of 18 hours.

To set the OFF DELAY:

- With the system in operation, enter the system OFF time by pressing the “▲” button to the desired number of hours ahead that the system will be allowed to run. When the number of hours entered has elapsed the system will turn off.

To set the ON DELAY:

- Set the on delay by entering the desired mode of operation (fan, heat, cool and the appropriate temperature. This will be the settings the system will follow when operation resumes. After setting the mode and any applicable temperature with the control, turn the remote off. Now enter the number of hours to elapse before operation resumes by pressing the “▲” button on the remote to the desired number. When the time (in hours) entered has elapsed, the system will resume operation according to the pre-set mode and temperature.



INSTALLATION & OPERATING MANUAL

MHWW Hi-Wall Fan Coils
36,000 BTUH

MHWW CONTROLS OPERATION GUIDE

7. CANCEL

- To cancel any setting on the delay timer.

8. LOUVER

- Two different functions are available:

1. To set the louver stop position. There are 4 angles available. The sequence is as follows.



2. To set the louver swing (continuous motion). The sequence is as follows.

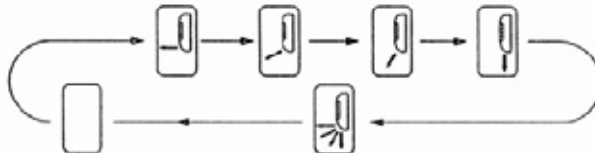

9. SLEEP

- This function when selected will allow the user to determine a “sleep” period. In cooling the selected temperature will rise to 1° above set point in 1/2 hour, rising to 2° in 1 hour, rising again to 4° after 2 hours of the SLEEP CYCLE.



SLEEP FUNCTION DISPLAY

10. DRY

- This function operates to control humidity within a conditioned space. It measures the difference between set point and the actual room temperature. An algorithm determines how far above set point the actual room temperature is to set point temperature and selects periods of water valve operation and low fan operation. The greater the difference between room temperature and set point temperature prompts greater run time with less temperature. With less temperature differences, periods of fan and valve operation are called for in varying increments as determined by the difference. In this mode (low speed) fan operation will start 30 seconds after valve has opened and stops 30 seconds after valve has closed.



INSTALLATION & OPERATING MANUAL

MHWW Hi-Wall Fan Coils
36,000 BTUH

MHWW CONTROLS OPERATION GUIDE

11. AUTO

- This function will automatically control the system switching between heating and cooling operation. If the preset auto mode is cooling, a switch to heating operation will begin only if the actual room temperature is 7° below selected control set point. If the present auto mode is heating, a switch to cooling operation will begin only when the room temperature is 3° above selected control set point.

12. TRANSMISSION INDICATOR

- Blinks twice to indicate that transmission has taken place between remote and receiver.
- Beeps indicate fan coil acknowledging receipt of transmission.



TRANSMISSION INDICATOR

13. HOW TO INSERT BATTERIES

1. Remove the battery cover from the back of the remote.
2. Insert the (2) AAA batteries. Ensure that the polarity of the batteries are as shown inside of the battery compartment.
3. Re-attach the battery compartment cover.





INSTALLATION & OPERATING MANUAL

MHWW Hi-Wall Fan Coils
36,000 BTUH

MHWW CONTROLS OPERATION GUIDE

Optional Wired Control: EG-003

LED MODE INDICATOR FOR REMOTE CONTROLLER:

INDICATOR LIGHTS	SETTING	FUNCTION
RED-GREEN	COOL	COOLING OPERATION ONLY
RED-RED	HEAT	HEATING OPERATION ONLY
RED-BLINKING	AUTO	AUTO SELECTION BETWEEN HEAT & COOL
RED-OFF	FAN	FAN OPERATION ONLY

1. POWER

- Press to turn the fan coil on and off or vice versa.

2. MODE

- To select desired operation mode.

It will switch from one to another as shown.

COOL - Cooling operation.

HEAT - Heating operation.

FAN - Fan only. No cooling or heating capability.

AUTO - Operation mode will be selected automatically between HEAT and COOL mode depending upon the room temperature and SET temperature.

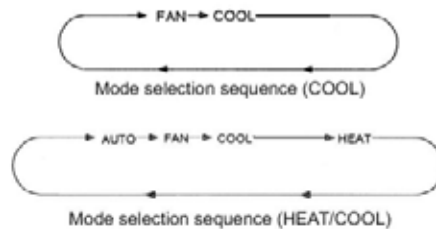

3. FAN

- To select fan speed. It will switch from one to another as shown below.
- When the system temperature sensor is not calling for cool or heat the fan will run at the speed previously entered in fan mode selection (high, medium or low).
- If auto was the previously entered fan speed in cooling: The fan will run at low speed until the temperature sensor calls for either heating or cooling at this point the fan will return to auto speed control

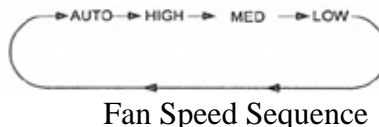



INSTALLATION & OPERATING MANUAL

MHWW Hi-Wall Fan Coils
36,000 BTUH

MHWW CONTROLS OPERATION GUIDE

FUNCTION

4. TEMPERATURE SETTING

- Press “▲” to increase set temperature.
- Press “▼” to decrease set temperature.
- Press “▲” and “▼” Simultaneously to toggle between °C and °F display mode.
- Temperature range: 16° C to 30°C in °C display mode and 60°F to 86°F in °F display mode.

(a) °C display mode

(b) °F display mode

5. CANCEL

- To cancel any setting on the delay timer.

6. LOUVER

- Two different functions are available:

1. To set the louver stop position. There are 4 angles available. The sequence is as follows.



2. To set the louver swing (continuous motion). The sequence is as follows.

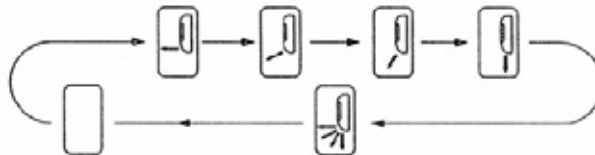

7. AUTO

- This function will automatically control the system switching between heating and cooling operation. If the present auto mode is cooling, a switch to heating operation will begin only if the actual room temperature is 7° below selected control set point. If the present auto mode is heating, a switch to cooling operation will begin only when the room temperature is 3° above selected control set point.

MHWW-36-H-1 Wiring Diagram

208/230/-1-50/60

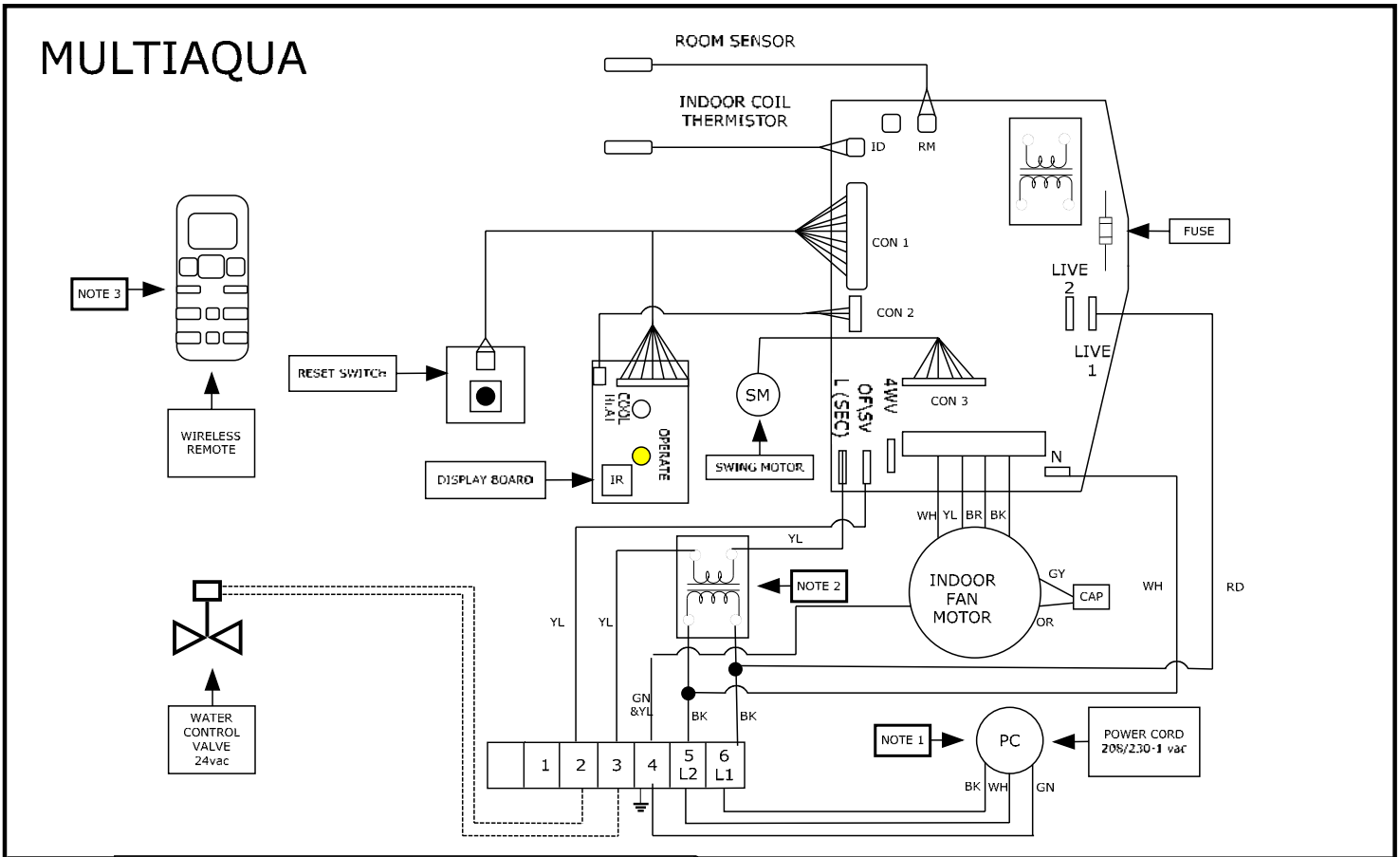

TITLE	MHWW-36-H-1
AUTHOR	kjg
DATE	09/14/07
REVISION	0907300044

LEGEND:	NOTES:
—————	FACTORY WIRING
-----	FIELD WIRING
⏚	GROUND
1.	POWER CORD IS EQUIPPED WITH A 3-PRONG MALE PLUG
2.	208/230 -24vac TRANSFORMER
3.	WIRELESS REMOTE INCLUDES A WALL MOUNTING BRACKET

MHWW-36-H-1 CERTIFIED DRAWING

MHWW Certified Drawing
 Drawing # 0907400080

