



MCCW Chilled/Hot Water Ceiling Concealed

2-Pipe Heat / Cool Fan Coil 48,000 - 60,000 BTUH

MCCW NOMENCLATURE BREAKDOWN

2-Pipe Heat/Cool Ceiling Concealed Fan Coil

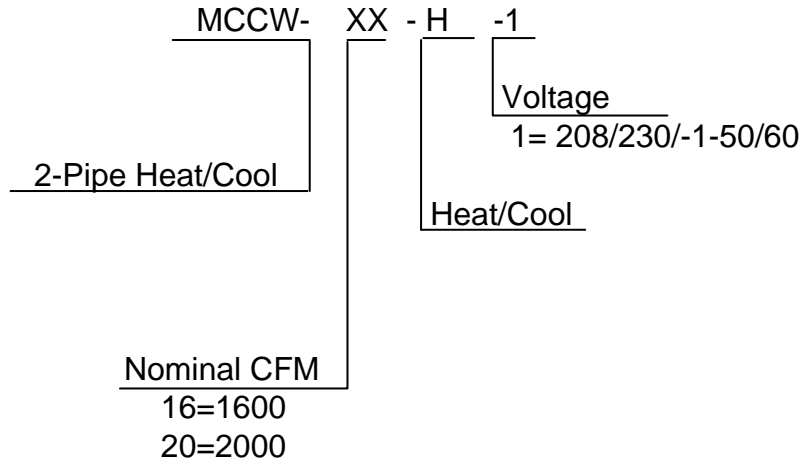

Available Model Numbers
MCCW-16-H-1 MCCW-20-H-1

HVAC Guide Specifications

Chilled and Hot Water Fan Coil
2-Pipe

Nominal Size:

48,000 – 60,000 BTUH

MultiAqua Model Number:

MCCW16

MCCW20

Part 1-General

1.01 System Description

MultiAqua Chilled Water Fan Coils are manufactured with heavy gauge galvanized steel to resist corrosion.

1.02 Quality Assurance

- A. Certified in accordance with U.L. Standard 95, latest version (U.S.A.)
- B. Manufactured in a facility registered to ISO 9002, Manufacturing Quality Standard.
- C. Fully load tested at the factory.
- D. Damage resistant packaging.

1.03 Delivery, Storage and Handling

- A. Packaged and readied for shipment from the factory.
- B. Controls shall be capable of withstanding 150°F storage temperatures in the control compartment.
- C. Stored and handled per manufacturer's recommendations.

Part 2-Product

2.01 Equipment

- A. General:
 1. Unit shall be a factory assembled and tested chilled and hot water fan coil.
 2. Shall be assembled with heavy gauge galvanized steel.
 3. Contained with the unit shall be all factory wiring, piping, associated controls and special accessories required prior to start up.
- B. Unit Cabinet:
 1. Composed of heavy gauge galvanized steel casing with a baked polyester powder.
 2. Shall be internally insulated to insure quiet operation.
- C. Fan Motors:
 1. Shall be available in 208/230-1-50/60 vac.
 1. Fan motors shall be three speed, direct drive, and PSC type.
 2. Totally enclosed.
 3. Internal overload protected.
- D. Blower Wheels:
 1. Blower wheels are forward curved and dynamically balanced.
- E. Water Coil:
 1. Manufactured with water coils containing 3/8" copper tubing mechanically bonded to aluminum fins.
 2. Contain both a manual water drain and manual air bleed port per coil.
 3. Coils shall be factory tested to 350 psig.
 4. Coils shall be capable of being field converted from right to left hand connection.
- F. Drain Pan:
 1. All drain pans shall be coated on both the interior and exterior with baked polyester powder to resist corrosion.
 2. The exterior of all drain pans shall be insulated with closed cell to prevent condensation.
 3. Pans shall contain a left and right hand primary sloped drain connection as well as a sloped right hand secondary drain connection.

Part 3-Controls and Safeties**3.01 Controls**

- A. Fan coils shall be completely factory wired and tested.
- B. All components shall be wired to an internal terminal block to allow for a field installed thermostat and or fan speed control.
- C. Controls shall include the following components.
 - 1. 24vac transformer.
 - 2. Fan relays.
 - 3. Optional thermostats.

3.02 Safeties:

- A. Fan coil shall contain a non reusable fuse on the secondary voltage side of the transformer.

Part 4-Operating Characteristics:**4.01 Electrical Requirements**

- A. Primary electrical power supply shall enter the unit at a single location.
- B. Electrical power supply shall be rated to withstand 120°F operating ambient temperatures.
- D. Control and high voltage points shall be accessed through terminal block.

MCCW Product Specifications

Physical Data									
Model Number	Height (in)	Length (in)	Depth (in)	Weight (lbs)	Cooling Rows FPI	Copper Diameter (in)	Water Inlet (in)	Water Outlet (in)	Drain (in)
MCCW-16-H-1	13.78	48.50	20.00	68.34	3-14	3/8	3/4	3/4	1/2
MCCW-20-H-1	13.78	56.10	20.00	72.80	3-14	3/8	1.0	1.0	1/2

Electrical Data							
Model Number	Nominal CFM	Volts/ Phase/ Hertz	Motor HP	Full Load Ampacity	Fuse or HACR Circuit Breaker Per Circuit		
					Minimum Amps	Maximum Amps	
MCCW-16-H-1	1600	208/230-1-50/60	1/2	2.72	3.40	8	
MCCW-20-H-1	2000	208/230-1-50/60	1/2	2.72	3.40	8	

These specifications are subject to change without notice.

MCCW Chilled Water Performance Data

MCCW-16 COOLING CAPACITIES					
NOMINAL CFM	EWT (°F)	GPM	ENTERING AIR TEMPERATURE (°F)		
				80° D.B. / 67° W.B.	75° D.B. / 63° W.B.
1600	42	7.0	TC	41.4	31.7
			SC	31.0	27.3
			WPD	4.7	4.7
		8.0	TC	43.4	33.1
			SC	31.7	27.8
			WPD	6.0	6.0
		9.0	TC	45.0	34.4
			SC	32.3	28.3
			WPD	7.4	7.4
		10.0	TC	46.4	35.4
			SC	32.8	28.7
			WPD	9.0	9.0

MCCW-16 COOLING CAPACITIES					
NOMINAL CFM	EWT (°F)	GPM	ENTERING AIR TEMPERATURE (°F)		
				80° D.B. / 67° W.B.	75° D.B. / 63° W.B.
1600	45	7.0	TC	38.0	29.0
			SC	29.7	26.3
			WPD	4.7	4.7
		8.0	TC	39.8	30.4
			SC	30.4	26.8
			WPD	6.0	6.0
		9.0	TC	41.3	31.5
			SC	30.9	27.2
			WPD	7.4	7.4
		10.0	TC	42.5	32.5
			SC	31.4	27.6
			WPD	9.0	9.0

These specifications are subject to change without notice.

MCCW Chilled Water Performance Data

MCCW-20 COOLING CAPACITIES					
NOMINAL CFM	EWT (°F)	GPM	ENTERING AIR TEMPERATURE (°F)		
				80° D.B. / 67° W.B.	75° D.B. / 63° W.B.
2000	42	9.0	TC	52.7	40.3
			SC	37.8	33.0
			WPD	9.4	9.4
		10.0	TC	54.3	41.5
			SC	38.4	33.5
			WPD	11.4	11.4
		11.0	TC	55.7	42.5
			SC	38.9	33.9
			WPD	13.5	13.5
		12.0	TC	56.8	43.4
			SC	39.4	34.2
			WPD	15.9	15.9

MCCW-20 COOLING CAPACITIES					
NOMINAL CFM	EWT (°F)	GPM	ENTERING AIR TEMPERATURE (°F)		
				80° D.B. / 67° W.B.	75° D.B. / 63° W.B.
2000	45	9.0	TC	48.4	37.0
			SC	36.1	31.7
			WPD	9.4	9.4
		10.0	TC	49.9	38.1
			SC	36.7	32.1
			WPD	11.4	11.4
		11.0	TC	51.1	39.0
			SC	37.2	32.5
			WPD	13.5	13.5
		12.0	TC	52.1	39.8
			SC	37.6	32.8
			WPD	15.9	15.9

These specifications are subject to change without notice.

MCCW Hot Water Performance Data

MCCW-16 HEATING CAPACITIES														
ENTERING AIR (°F)	NOMINAL CFM	GPM	WPD	ENTERING WATER TEMPERATURE (°F)										
				100°	110°	120°	130°	140°	150°	160°	170°	180°	190°	200°
50	1600	7.0	4.7	50.9	61.0	71.2	81.4	91.5	101.7	111.9	122.1	132.2	142.4	152.6
		8.0	6.0	51.8	62.2	72.5	82.9	93.2	103.6	114.0	124.3	134.7	145.0	155.4
		9.0	7.4	52.6	63.1	73.6	84.1	94.6	105.2	115.7	126.2	136.7	147.2	157.7
		10.0	9.0	53.2	63.9	74.5	85.2	95.8	106.4	117.1	127.7	138.4	149.0	159.7

MCCW-16 HEATING CAPACITIES														
ENTERING AIR (°F)	NOMINAL CFM	GPM	WPD	ENTERING WATER TEMPERATURE (°F)										
				100°	110°	120°	130°	140°	150°	160°	170°	180°	190°	200°
60	1600	7.0	4.7	40.7	50.9	61.0	71.2	81.4	91.5	101.7	111.9	122.1	132.2	142.4
		8.0	6.0	41.4	51.8	62.2	72.5	82.9	93.2	103.6	114.0	124.3	134.7	145.0
		9.0	7.4	42.1	52.6	63.1	73.6	84.1	94.6	105.2	115.7	126.2	136.7	147.2
		10.0	9.0	42.6	53.2	63.9	74.5	85.2	95.8	106.4	117.1	127.7	138.4	149.0

MCCW-16 HEATING CAPACITIES														
ENTERING AIR (°F)	NOMINAL CFM	GPM	WPD	ENTERING WATER TEMPERATURE (°F)										
				100°	110°	120°	130°	140°	150°	160°	170°	180°	190°	200°
70	1600	7.0	4.7	30.5	40.7	50.9	61.0	71.2	81.4	91.5	101.7	111.9	122.1	132.2
		8.0	6.0	31.1	41.4	51.8	62.2	72.5	82.9	93.2	103.6	114.0	124.3	134.7
		9.0	7.4	31.5	42.1	52.6	63.1	73.6	84.1	94.6	105.2	115.7	126.2	136.7
		10.0	9.0	31.9	42.6	53.2	63.9	74.5	85.2	95.8	106.4	117.1	127.7	138.4

MCCW-16 HEATING CAPACITIES														
ENTERING AIR (°F)	NOMINAL CFM	GPM	WPD	ENTERING WATER TEMPERATURE (°F)										
				100°	110°	120°	130°	140°	150°	160°	170°	180°	190°	200°
80	1600	7.0	4.7	20.3	30.5	40.7	50.9	61.0	71.2	81.4	91.5	101.7	111.9	122.1
		8.0	6.0	20.7	31.1	41.4	51.8	62.2	72.5	82.9	93.2	103.6	114.0	124.3
		9.0	7.4	21.0	31.5	42.1	52.6	63.1	73.6	84.1	94.6	105.2	115.7	126.2
		10.0	9.0	21.3	31.9	42.6	53.2	63.9	74.5	85.2	95.8	106.4	117.1	127.7

These specifications are subject to change without notice.

MCCW Hot Water Performance Data

MCCW-20 HEATING CAPACITIES														
ENTERING AIR (°F)	NOMINAL CFM	GPM	WPD	ENTERING WATER TEMPERATURE (°F)										
				100°	110°	120°	130°	140°	150°	160°	170°	180°	190°	200°
50	2000	9.0	9.4	58.9	70.7	82.5	94.3	106.0	117.9	129.6	141.4	153.2	165.0	176.8
		10.0	11.4	59.6	71.6	83.5	95.4	107.4	119.3	131.2	143.1	155.1	167.0	178.9
		11.0	13.5	60.2	72.3	84.3	96.4	108.4	120.5	132.5	144.6	156.6	168.7	180.7
		12.0	15.9	60.7	72.9	85.0	97.1	109.3	121.4	133.6	145.7	157.8	170.0	182.1

MCCW-20 HEATING CAPACITIES														
ENTERING AIR (°F)	NOMINAL CFM	GPM	WPD	ENTERING WATER TEMPERATURE (°F)										
				100°	110°	120°	130°	140°	150°	160°	170°	180°	190°	200°
60	2000	9.0	9.4	47.1	58.9	70.7	82.5	94.3	106.1	117.9	129.6	141.4	153.2	165.0
		10.0	11.4	47.7	59.6	71.6	83.5	95.4	107.4	119.3	131.2	143.1	155.1	167.0
		11.0	13.5	48.2	60.2	72.3	84.3	96.4	108.4	120.5	132.5	144.6	156.6	168.7
		12.0	15.9	48.6	60.7	72.9	85.0	97.1	109.3	121.4	133.6	145.7	157.8	170.0

MCCW-20 HEATING CAPACITIES														
ENTERING AIR (°F)	NOMINAL CFM	GPM	WPD	ENTERING WATER TEMPERATURE (°F)										
				100°	110°	120°	130°	140°	150°	160°	170°	180°	190°	200°
70	2000	9.0	9.4	35.4	47.1	58.9	70.7	82.5	94.3	106.1	117.9	129.6	141.4	153.2
		10.0	11.4	35.8	47.7	59.6	71.6	83.5	95.4	107.4	119.3	131.2	143.1	155.1
		11.0	13.5	36.1	48.2	60.2	72.3	84.3	96.4	108.4	120.5	132.5	144.6	156.6
		12.0	15.9	36.4	48.6	60.7	72.9	85.0	97.1	109.3	121.4	133.6	145.7	157.8

MCCW-20 HEATING CAPACITIES														
ENTERING AIR (°F)	NOMINAL CFM	GPM	WPD	ENTERING WATER TEMPERATURE (°F)										
				100°	110°	120°	130°	140°	150°	160°	170°	180°	190°	200°
80	2000	9.0	9.4	23.6	35.4	47.1	58.9	70.7	82.5	94.3	106.1	117.9	129.6	141.4
		10.0	11.4	23.9	35.8	47.7	59.6	71.6	83.5	95.4	107.4	119.3	131.2	143.1
		11.0	13.5	24.1	36.1	48.2	60.2	72.3	84.3	96.4	108.4	120.5	132.5	144.6
		12.0	15.9	24.3	36.4	48.6	60.7	72.9	85.0	97.1	109.3	121.4	133.6	145.7

These specifications are subject to change without notice.

MCCW CFM and Glycol Adjustments

Nominal CFM vs. External Static Pressure Table						
Model Number	Hi Speed					
	0.05	0.10	0.15	0.20	0.25	0.30
MCCW-16	1435	1420	1390	1355	1316	1281
MCCW-20	1435	1415	1400	1363	1325	1290

Example:

MCCW-16 @ 0.30 ESP produces 1281 cfm.

Locate 1281 cfm (for the MCCW-16) on the Capacity Adjustment Factors on page 157. (TC = .91 & SC = .89)

Multiply the stated chilled water capacity for the MCCW-16 on page 153 or the hot water capacity on page 155 by the adjustment factors to achieve the capacity adjustment.

Propylene Glycol & GPM Adjustment Factors			
Ambient Temp	Propylene Glycol %	Capacity Reduction	GPM Adjustment = 100% Capacity
26° F	10%	x 0.99	x 1.01
20° F	20%	x 0.98	x 1.03
8° F	30%	x 0.98	x 1.07
-5° F	40%	x 0.97	x 1.11
-28° F	50%	x 0.96	x 1.16

Example:

30% Propylene Glycol Solution.

System capacity x 0.98

GPM x 1.07

CAPACITY CORRECTION FACTORS				
MODEL #	MCCW-16		MCCW-20	
CFM	TC	SC	TC	SC
1281	0.91	0.89		
1290	0.91	0.89	0.92	0.92
1300	0.92	0.92	0.92	0.92
1325	0.94	0.93	0.94	0.93
1350	0.96	0.95	0.96	0.95
1375	0.97	0.96	0.97	0.96
1400	0.99	0.99	0.99	0.99
1435	1	1	1	1

These specifications are subject to change without notice

INSTALLATION and OPERATION MANUAL

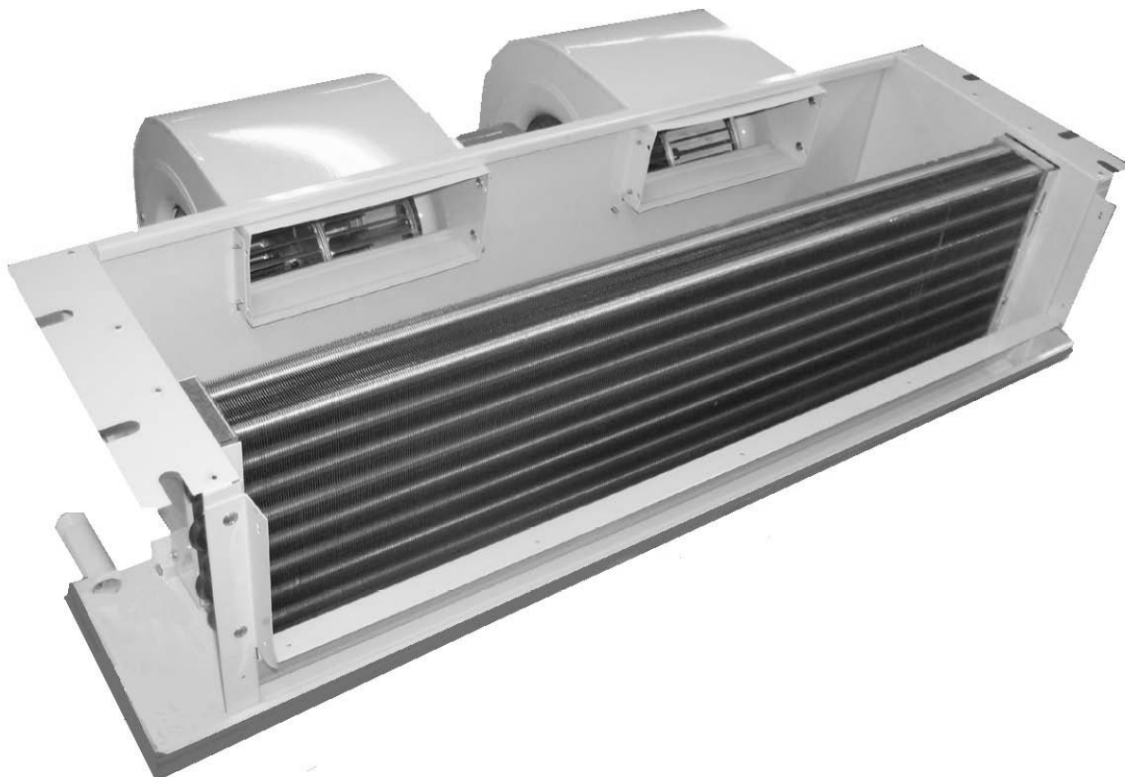

MCCW





INSTALLATION & OPERATING MANUAL

MCCW Fan Coils 4 & 5 Tons

----- CAUTION -----

Care must be taken when handling sheet metal. Sheet metal parts have sharp edges and could cause injury.

GENERAL

Read the entire contents of this manual before beginning installation. Multiaqua assumes no responsibility for equipment installed contradictory to any code requirement or installation instructions.

The components of this fan coil have been inspected at the factory and readied for shipment. Upon receiving the shipment a visual inspection of the packaging must be performed.

If any damage to the packaging is discovered, an inspection of the components must be performed and noted on the delivery documents. If component damage is found a damage claim must be filed by the receiving party against the delivery party immediately.

This product is designed and manufactured to permit installation in accordance with national codes. It is the installer's responsibility to install the product in accordance with national codes and/or prevailing local codes and regulations.

Care must be taken to ensure the structural integrity of the supporting members, clearances and provisions for servicing, power supply, coil connections and/or condensate removal. Before the installation ensure the structural strength of the supporting members is sufficient. See figure 1 for hanging weights of the fan coils.

This unit is designed to be installed in a

horizontal configuration only. See figure 2 for fan coil only dimensions.

The coil hand of connection is field reversible. See figures 3-5 for converting the coil hand of connection.

FAN COIL MODEL NUMBER	APPROXIMATED WEIGHTS (LBS)
MCCW-16	68.34
MCCW-20	72.80

Figure 1



INSTALLATION & OPERATING INSTRUCTIONS

MCCW Fan Coils 4 & 5 Tons

FAN COIL DIMENSIONS						
Fan Coil Model Number	A	B	C	D	E	F
MCCW16	56.38	51.85	50.20	13.74	9.49	19.80
MCCW20	56.38	51.85	50.20	13.74	9.49	19.80

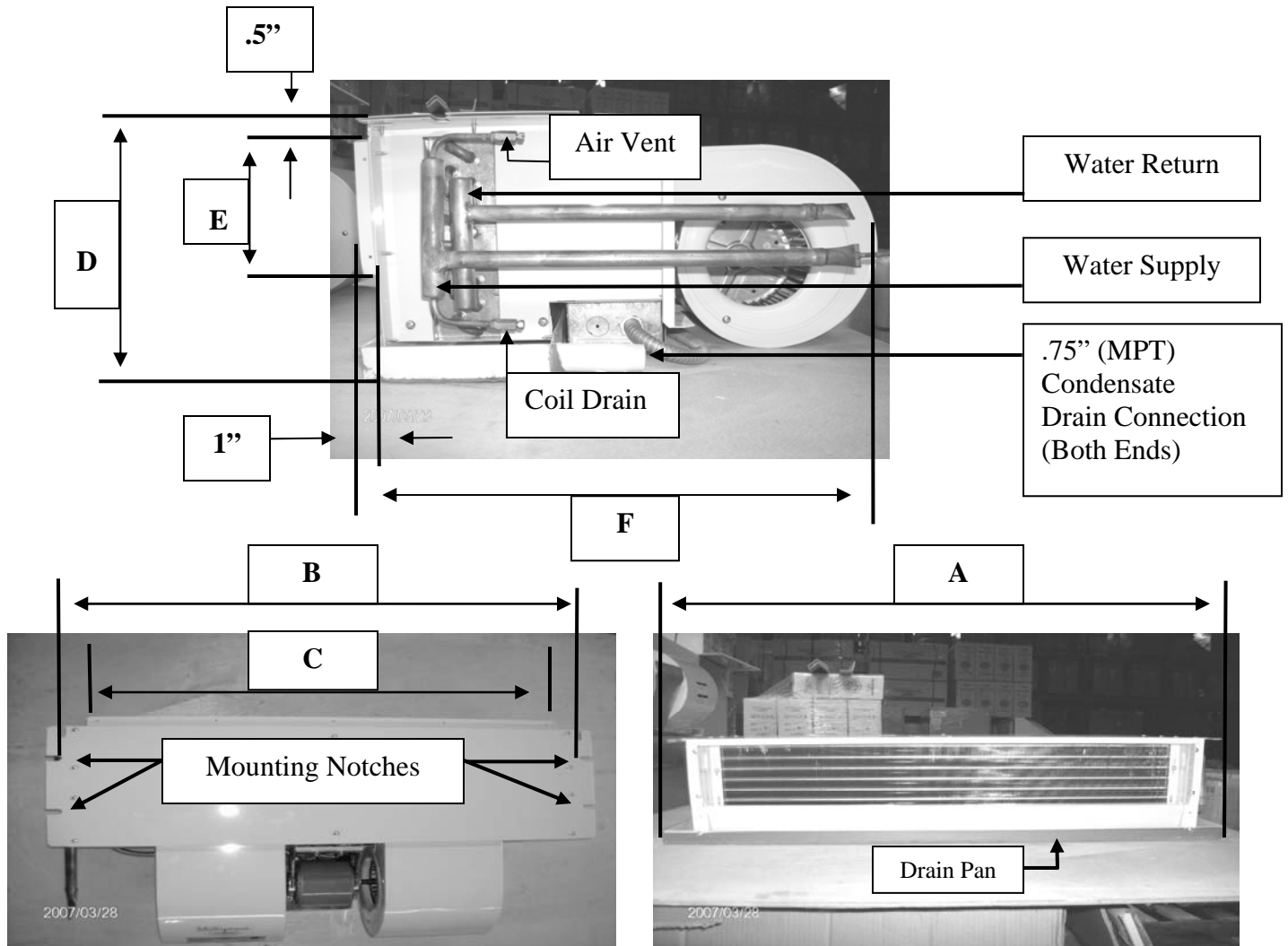

Figure 2

----- CAUTION -----

Care must be taken when handling sheet metal. Sheet metal parts have sharp edges and could cause injury.

INSTRUCTIONS FOR CONVERTING COIL HAND OF CONNECTION

1. Remove the eleven screws that attach the top to the fan coil assembly and remove the top.

Figure 3

2. Remove the eight screws that hold the coil into the fan coil frame assembly. Four screws per side.

Figure 4

3. Slide the coil out of the fan coil frame assembly toward the coil supply and return line connections. Ensure that care is taken when removing and inserting the coil not to damage the coil fins. Insert the coil into the fan coil frame assembly from the other end and reverse procedures 3 & 4 to reassemble the fan coil.

Figure 5

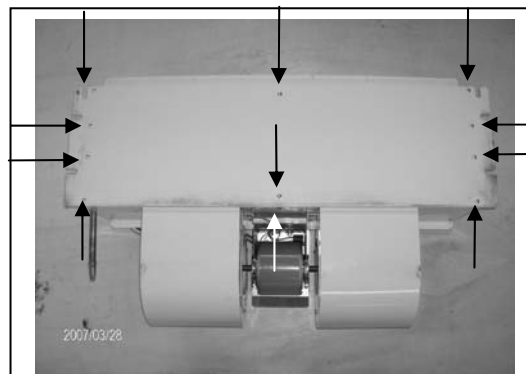

Figure 3



Figure 4



Figure 5

INSTRUCTIONS FOR INSTALLING FAN COIL UNIT INTO ENCLOSURE ASSEMBLY

1. Remove the ten screws that attach the electrical assembly to the fan coil unit. Do not separate the electrical assembly from the blower assembly. These two assemblies will be removed in the next step.

Figure 6

2. Remove the five screws attaching the blower assembly to the coil assembly. Separate the electrical and blower assemblies from the coil assembly.

Figure 7

3. Insert the coil assembly into the enclosure assembly starting with the discharge air opening of the coil first. Ensure that the discharge of the coil is inserted into the discharge of the enclosure completely. Failure to completely insert the coil discharge will result in recirculation of the discharge air.

Figure 8

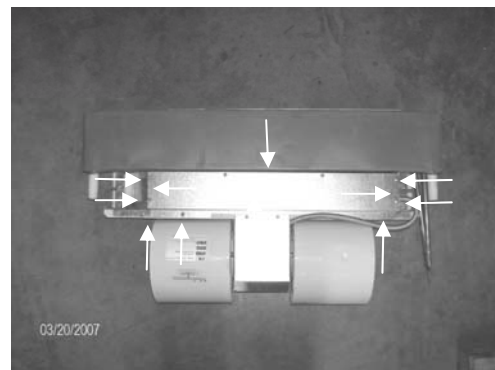

Figure 6

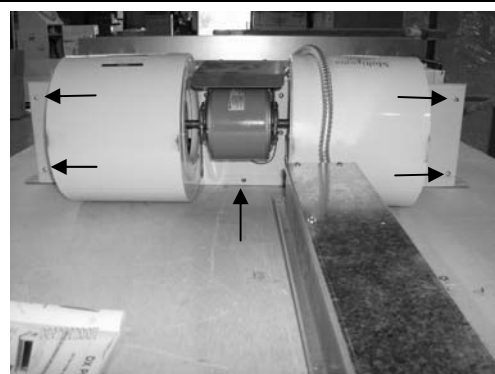

Figure 7

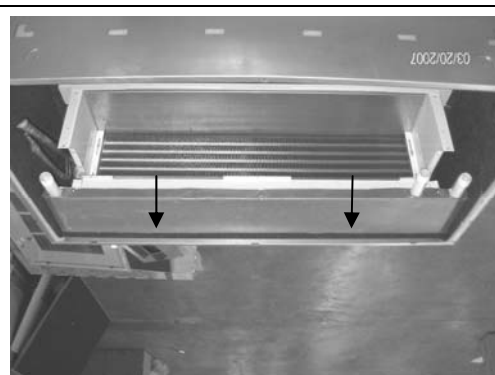

Figure 8

4. Align the fan coil mounting bolts up with the four mounting notches provided in the coil assembly top. Secure the coil assembly to the enclosure with two mounting bolts per side. Ensure that the coil assembly is level in both directions to allow proper drainage and operation.

Figure 9

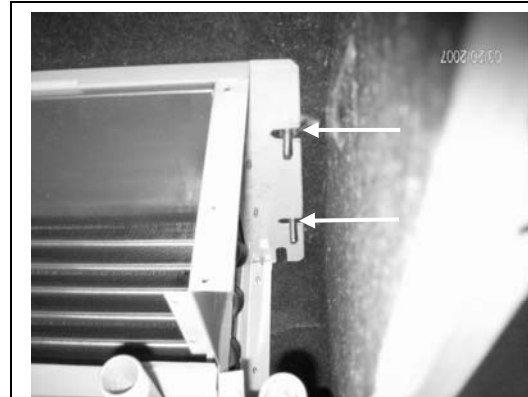

Figure 9

5. Reinstall the blower assembly onto the coil assembly using the five screws previously removed in step 2 figure 7.

Figure 10



Figure 10

6. Reinstall the electrical assembly onto the coil assembly using the ten screws previously removed in step 1 figure 6.

Figure 11



Figure 11

ELECTRICAL, COIL, DRAIN AND RETURN / SUPPLY AIR LOCATIONS

7. There are multiple entry points on the factory supplied enclosure assembly for water lines, condensate lines, refrigerant lines and electrical connections. If a non-louvered service access panel is used or if an alternate return air location is required an optional return air cutout is provided.

Figure 12

ELECTRICAL & CONDENSATE DRAIN

8. There are four termination points for the electrical wiring. There are two on each side of the electrical box. See page 169 for electrical drawings. Wiring must be installed according to prevailing codes and regulations.

The fan coil unit has one condensate drain connection on either side of the drain pan for either left or right hand drain connection. The opposite drain connection not being used must be capped off by the installing contractor. The middle drain connection is the safety condensate drain connection. Ensure that all condensate drain lines have at least one quarter of an inch of fall per foot for proper drainage.

Figure 13

WATER COIL CONNECTIONS

9. The fan coil unit comes with a manual air bleed and a manual coil drain fitting. They are located on the same side as the supply and return water line connections. The water supply line is connected to the coil connection furthest away from the fans. The water return line is connected to the coil connection closest to the fans. Ensure that both the supply and return water lines are insulated to prevent them from sweating.

Figure 14

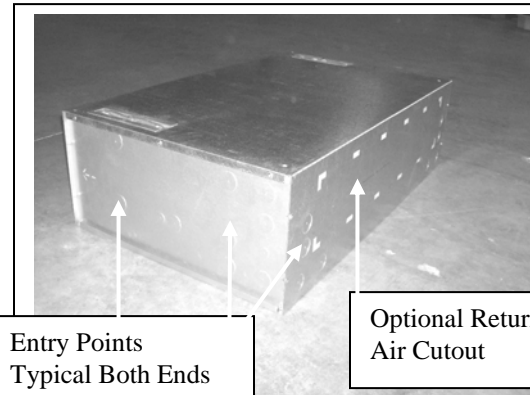

Figure 12

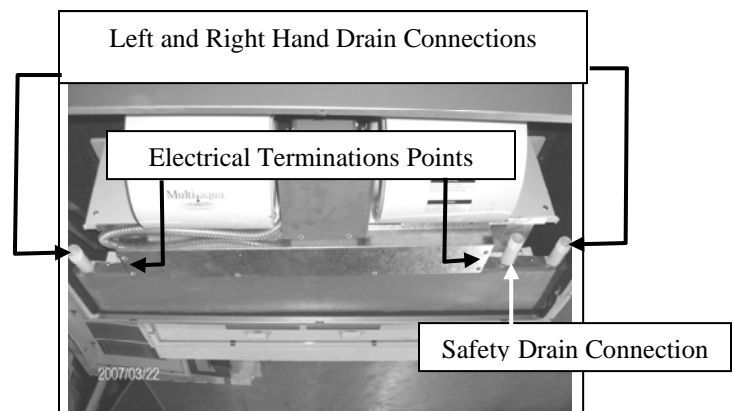

Figure 13

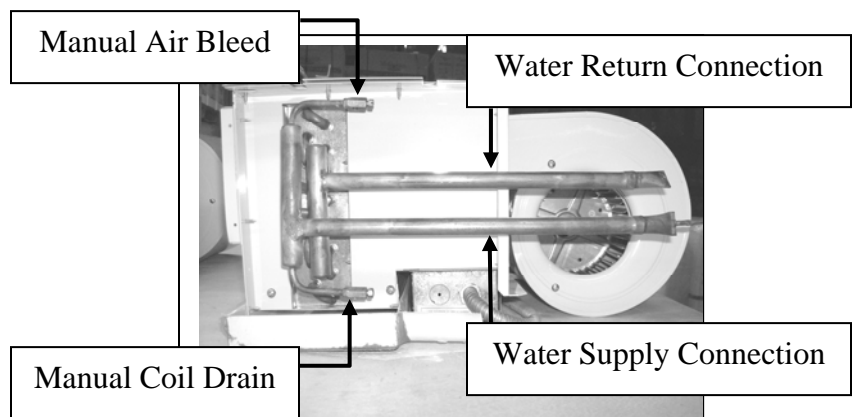

Figure 14

RETURN AND SUPPLY AIR CONNECTIONS

10. When mounting the service access panel, louvered or non-louvered, the installing contractor must provide a frame in order to connect the enclosure assembly to the service access panel. This is required to obtain an airtight seal for the return air. Ensure that the material used for the frame adheres to national codes and / or local codes and regulations. Care must be taken when installing the service access panel to ensure the opening of the hinged service panel.

Figure 15 & 16

11. Filters are not supplied with the fan coil unit or the service access panel. The filter(s) must be supplied by the installing contractor. If a louvered service access panel is used the filter will mount on the under side of the hinged access panel. If the optional return air cutout is used it is recommended that a return air filter grille be used that has the same surface area as the recommended filter sizes.

Figure 17

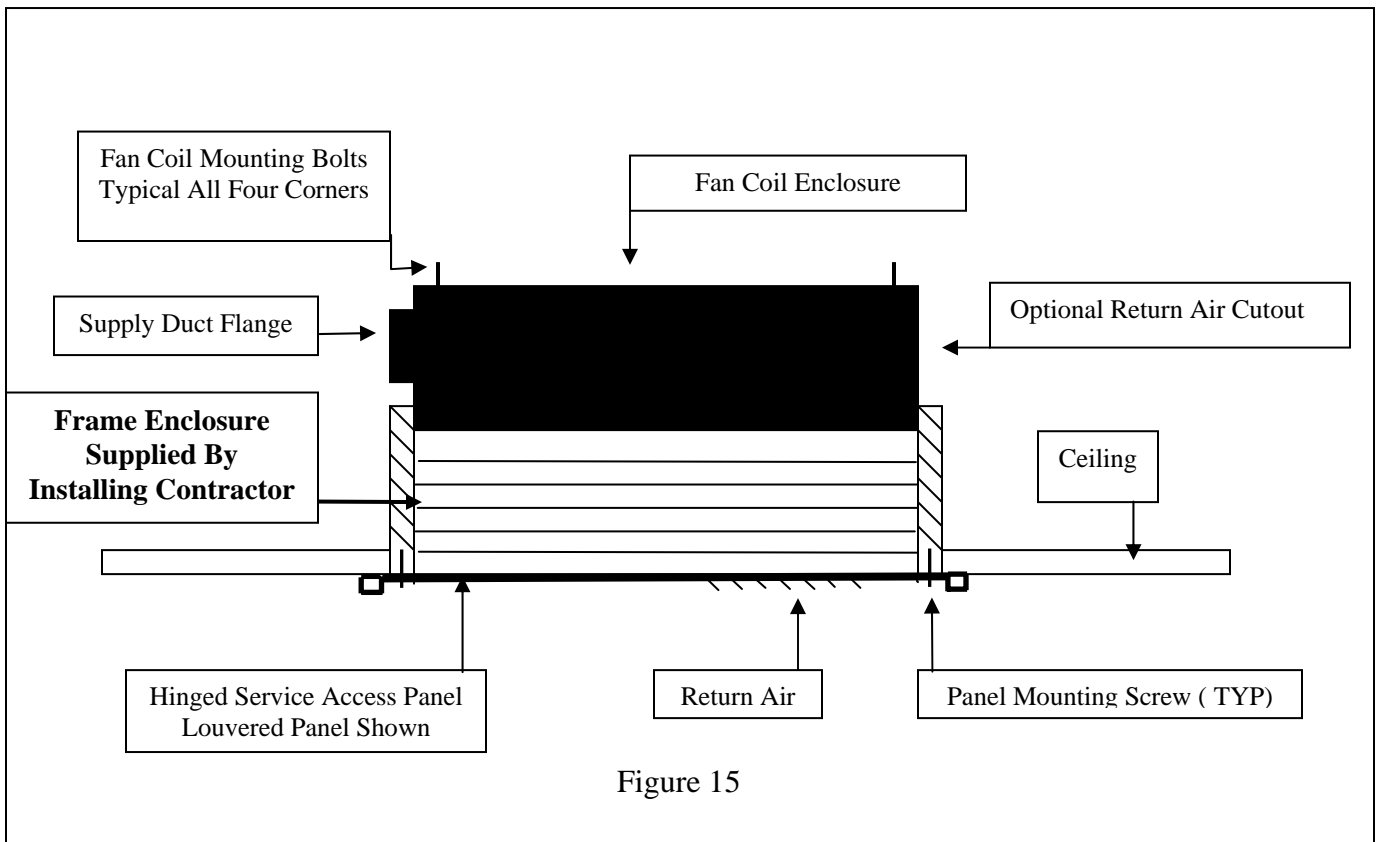



INSTALLATION & OPERATION MANUAL

MCCW Fan Coils 4 & 5 Tons

SERVICE ACCESS PANEL DIMENSIONS				
Louvered & Non-Louvered				
Panel Model Number	Fan Coil Size	A (in)	B (in)	C (in)
MAP468L(NL)	4	43.25	27.5	1.5
MAP468L(NL)	6	43.25	27.5	1.5
MAP468L(NL)	8	43.25	27.5	1.5
MAP10L (NL)	10	49.25	27.5	1.5
MAP12L (NL)	12	55.25	27.5	1.5

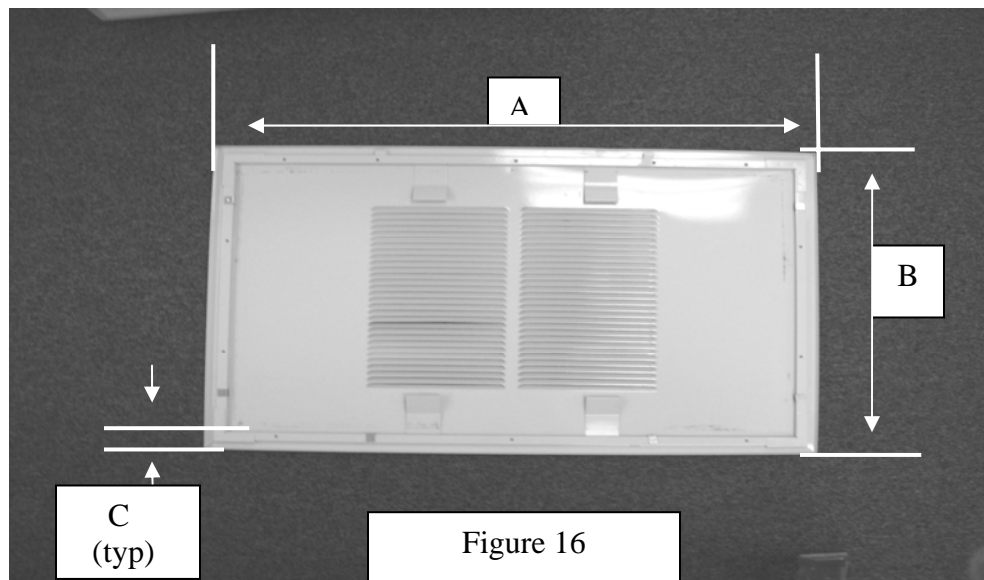

FAN COIL MODEL NUMBER	RECOMMENDED FILTER SIZES	
	Width (in)	Length (in)
MHNCCW04	18	36
MHNCCW06	18	36
MHNCCW08	18	36
MHNCCW10	18	36
MHNCCW12	2 qty 18	24

Figure 17



INSTALLATION & OPERATION MANUAL

MCCW Fan Coils 4 & 5 Tons

12. The fan coil enclosure assembly has a supply air duct flange to allow the attachment of ductwork. Ensure when attaching ductwork to the flange that the screws are at least one and half inches away from the front of the enclosure. This is to allow proper insertion of the fan coil assembly into the enclosure assembly when duct work will be installed before the fan coil is installed.

Figure 18

SUPPLY AIR DUCT FLANGE			
Enclosure Model Number	Fan Coil Size	A (in)	B (in)
MAP468L(NL)	4	6	31.75
MAP468L(NL)	6	6	31.75
MAP468L(NL)	8	6	31.75
MAP10L (NL)	10	6	37.75
MAP12L (NL)	12	6	43.75

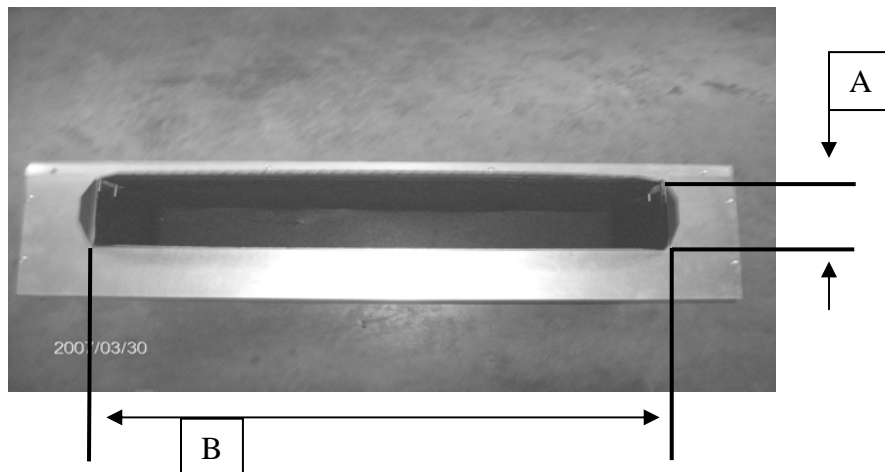

Figure 18



INSTALLATION & OPERATION MANUAL

MCCW Fan Coils 4 & 5 Tons

MAINTENANCE

1. Air Filter(s):

Filters are an essential part of the quality of air that is provided to the occupants. Never operate HVAC equipment without filters. Filters help remove dust and unwanted particles from the air stream, helping to keep the space clean. They also keep this debris from collecting on the heat transfer surfaces of the unit thus maintaining optimum equipment efficiency and performance. These filters will be located either in the unit or upstream from the unit in the return air ductwork. Filters must be inspected, cleaned and/or changed routinely. This routine maintenance procedure will allow the unit to continually operate as designed, reduce service expenses and extend equipment/component life.

2. Fuses and/or Circuit Breakers:

This unit must be connected to the buildings electric service in accordance with local/national electrical codes and regulations. These electrical connections will include over current protection in the form of fuses or circuit breakers. Have your contractor identify/label the circuits and the location of them so that you may be in a position to make inspections

and/or replacements in the event the unit fails to operate or is being serviced. If fuses are used, ensure that the replacement fuses are of the same size and type as the ones you are replacing. It is a good idea to keep replacement fuses of the appropriate size and type on hand.

3. Routine Check Up and Service:

This product is designed to provide many years of dependable, trouble free comfort when properly maintained. Proper maintenance will consist of routine filter cleanings/ changes, bi-annual check ups that include but not limited to filter inspections, inspections /cleaning of the internal electrical and heat transfer components by a qualified service technician. Failure to provide periodic check ups and cleaning can result in excessive operating cost and/or equipment failure.

MCCW-xx-01 Wiring Diagram

208/230-1-50/60

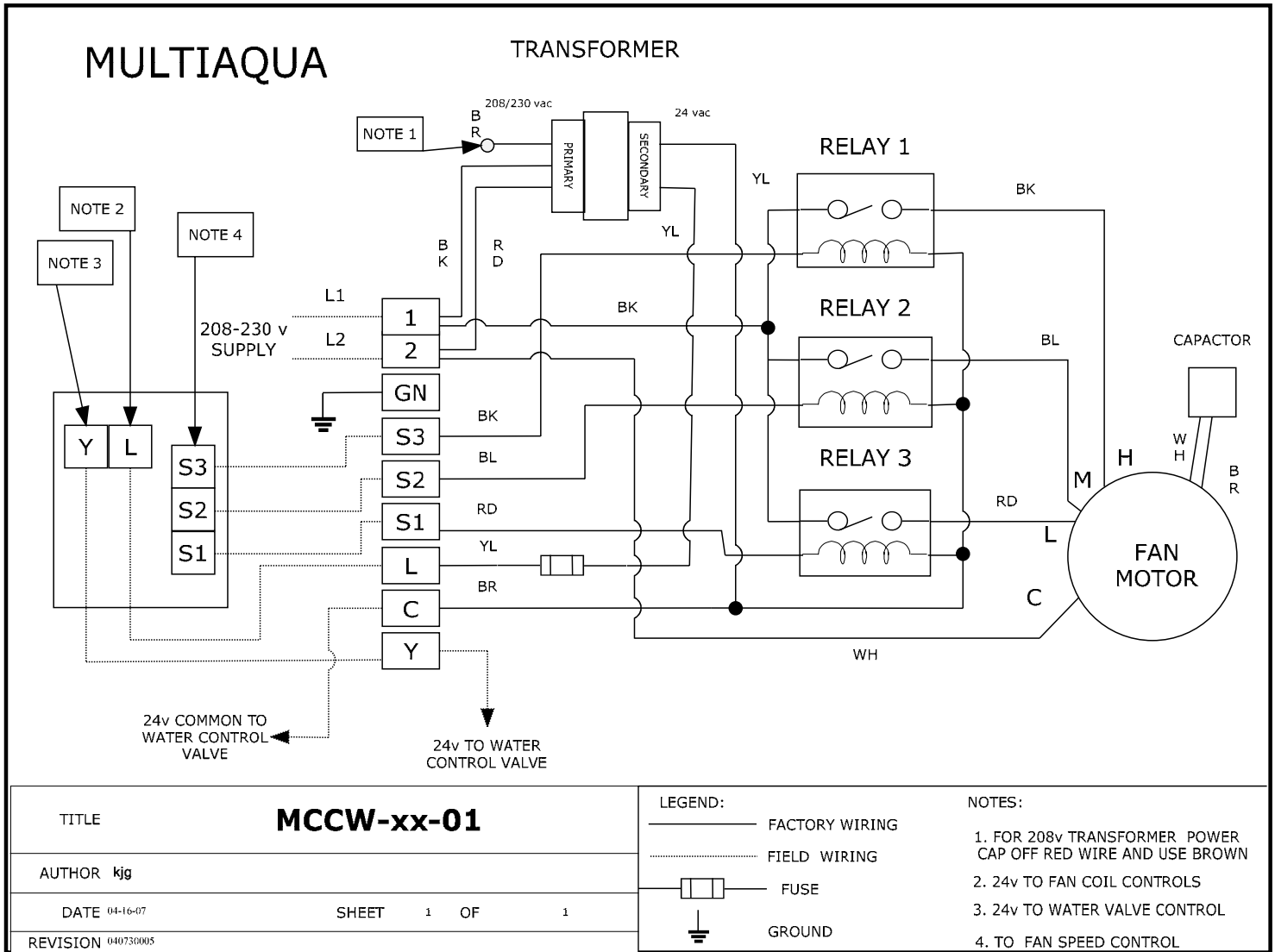

MCCW CERTIFIED DRAWING

MCCW Certified Drawing
 Drawing # 0907400072

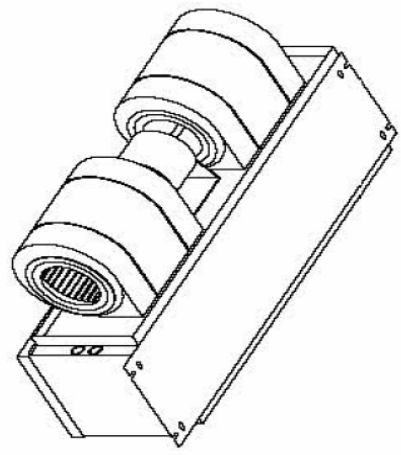
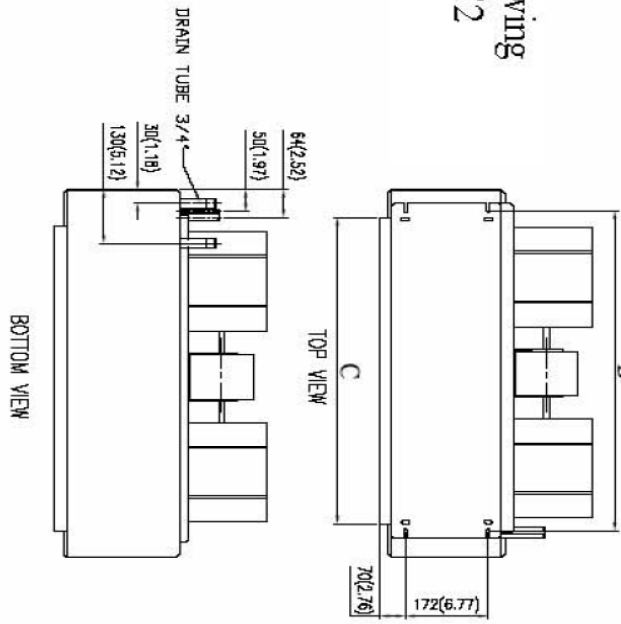
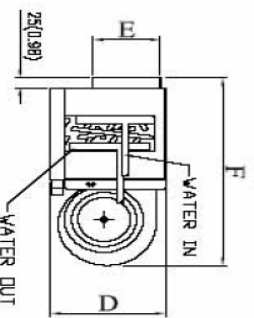
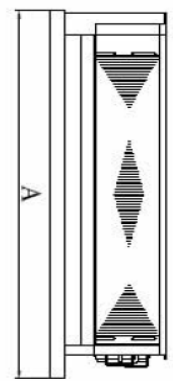
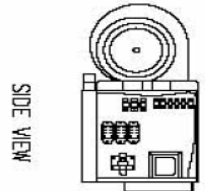

Model MCCW

MODEL	A	B	C	D	E	F
04	958(37.72)	843(33.19)	801(31.54)	247(9.72)	139(5.47)	455(17.91)
06	958(37.72)	843(33.19)	801(31.54)	247(9.72)	139(5.47)	455(17.91)
08	958(37.72)	843(33.19)	801(31.54)	247(9.72)	139(5.47)	455(17.91)
10	1238(48.74)	1123(44.21)	1081(42.56)	298(11.73)	189(7.44)	455(17.91)
12	1238(48.74)	1123(44.21)	1081(42.56)	298(11.73)	189(7.44)	503(19.80)
16	1432(56.38)	1317(51.85)	1275(50.20)	349(13.74)	241(9.49)	503(19.80)
20	1432(56.38)	1317(51.85)	1275(50.20)	349(13.74)	241(9.49)	503(19.80)