

The Moline SugarKing



A Modular Donut Sugaring System delivering a uniform and consistent sugar coating during high volume production.

The Moline SugarKing provides a gentle, continuous sugar coating action for donuts or similar product, and can be used with powdered, granulated or cinnamon sugar. The modular design facilitates portability, quick topping change-overs and easy access for sanitation.

Sugar in the hopper is loosened automatically by an agitator and fed through the screw conveyor up to the sugar infeed chute where it enters the stationary drum. The sugar coats the product through a perforated, rotating inner drum as the donuts move through the sugar zone in a gentle turning, tumbling motion to the discharge conveyor. Loose

sugar is continuously agitated and carried through the machine while the unused sugar is automatically recaptured and returned to the hopper via the sugar discharge chute, reducing waste.

Production capacity range varies from approximately 10,000 - 30,000 donuts per hour. (Actual capacity is a function of donut size, donut and coating characteristics and coverage requirements).

Systems are available in right or left hand control with 3 phase power input. Control hand and voltage must be specified at the time of order placement.

- **Modular and mobile stainless steel design facilitates portability and access for sanitation.**
- **Gentle coating action with high volume production.**
- **Accommodates powdered, granulated or cinnamon sugar.**
- **Recirculating sugar supply to reduce waste.**



Packaging - Processing
Bid on Equipment
1-847-683-7720
www.bid-on-equipment.com



Moline Machinery LLC

114 South Central Avenue • Duluth, Minnesota, USA, 55807
218-624-5734 (For after hours service, call 218-590-1987)
www.moline.com • sales@moline.com



The Moline SugarKing

Tumbling Module Features:

- Mobile design (on casters) and stainless steel construction.
- Stationary outer drum includes quick-release input coupling for sugar supply and closed-loop discharge port allowing excess sugar to flow back to the hopper.
- Hinged access panels and a waste drain are included for inspection and sanitation.
- The variable speed perforated inner drum includes sugar dispensing paddles and a spiral guide to transfer and tumble donuts.
- Powered infeed and discharge conveyors are of stainless steel rod belting at 3/4" pitch.
- A stainless steel control panel is mounted to the tumbler frame (NEMA 4 and IP65 rated).
- Optional Clean-In-Place (CIP) System available, with internal piping and spray nozzles mounted to stationary drum. Quick-release fittings for water supply.



Sugar Feed Module Features:

- Mobile design (on casters) and stainless steel construction.
- Hopper holding capacity: of 300 lbs. (136 kg).
- Anti-bridging vibrators mounted to hopper side walls.
- Powered agitator to transfer viscous dry material from hopper to auger.
- Variable speed incline auger with coupling discharge matches tumbler input. Auger is

removable without tools for maintenance and/or sanitation.

- Quick-release position couplings connect sugar feed module to tumbler frame.
- Power cord and controls are included to interface with tumbler control panel.
- Optional sugar feed module is available (without agitator) for free flowing granulated sugar only.

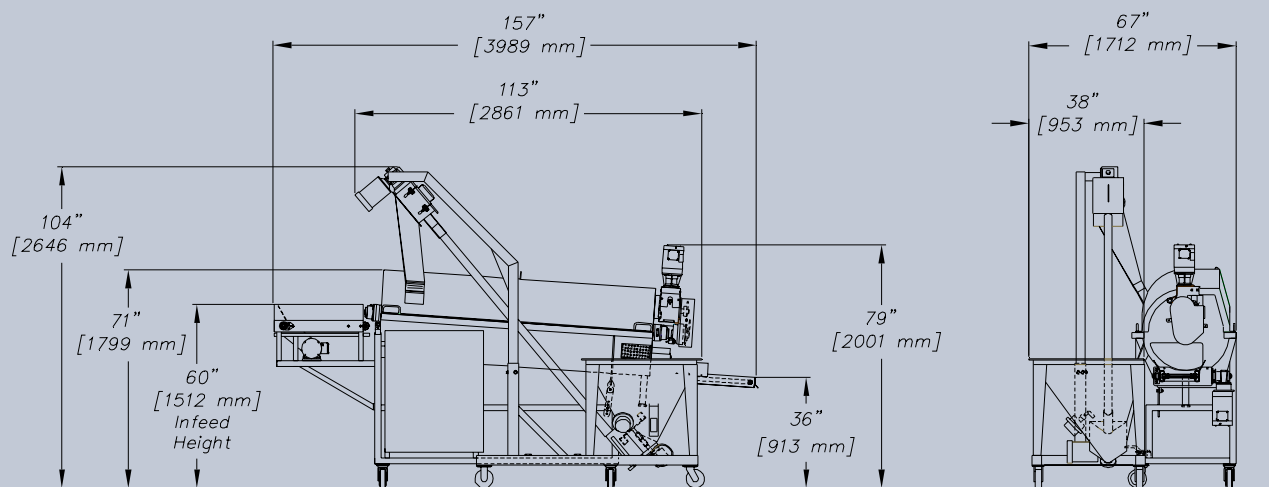

Sugaring Unit and Sugar Feed Unit

Dimensions are approximate. Contact Moline Customer Service for a certified drawing.

Due to continuous product improvement, specifications are subject to change without notice.