

# Moline Frying Oil Filtration System



**Providing efficient and continuous frying oil filtration during production.**

The Moline frying oil filtration system is designed to continuously filter frying oil during production, promoting frying oil quality and decreasing fryer down time for sanitation.

The filter is directly connected to the fryer via piping. Sediment waste is continuously removed and the filtered oil is returned to the fryer for reuse. A wire mesh conveyor belt, providing 60-micron filtration, strains and filters the frying oil inside the filter tank. Sediment and debris are carried out of the tank through the

discharge chute to a collection bin positioned below.

Three pumps are installed on the filter frame: one for infeed, one for discharge and an auxiliary pump for pumping the frying oil to a storage system. Shutoff valves are provided for all piping connections.

The filter can be easily integrated with existing frying systems and is controlled through the production system's operator interface.

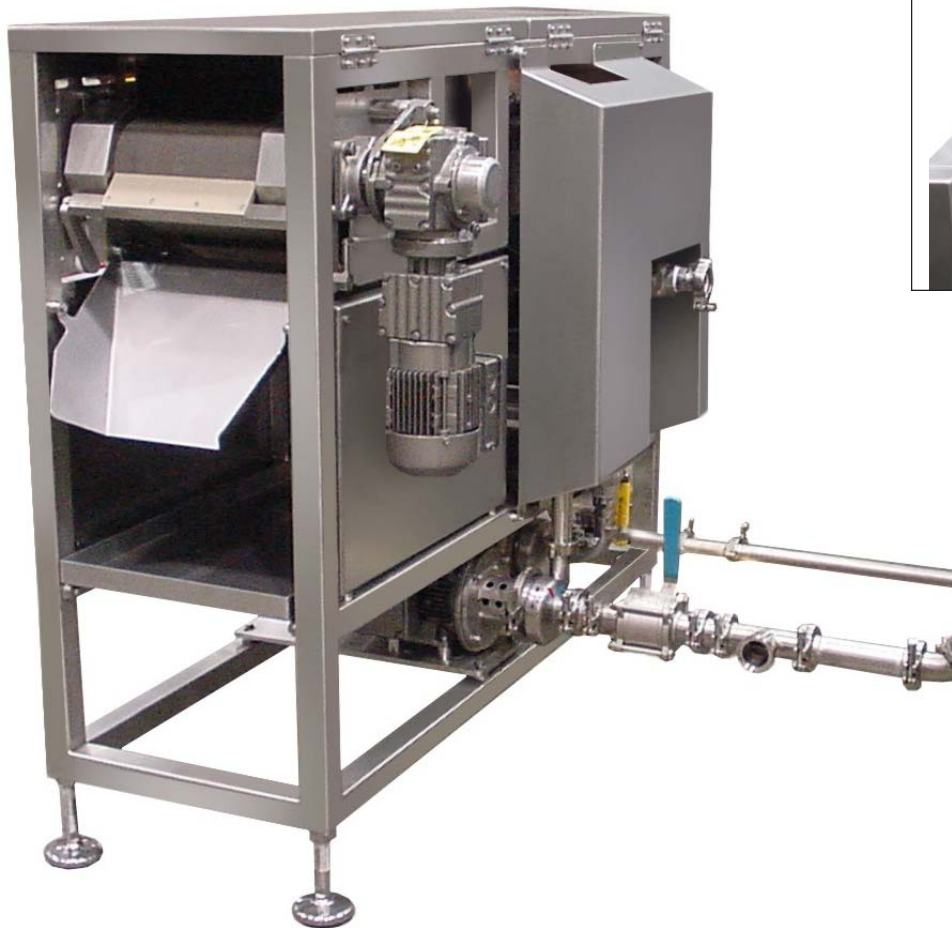

- Promotes frying oil quality and reduces down time for sanitation.
- Provides 60-micron filtration of frying oil. Optional filter paper provides 5-micron filtration.
- Easily integrated with existing systems.

Packaging - Processing  
**Bid on Equipment**  
1-847-683-7720  
[www.bid-on-equipment.com](http://www.bid-on-equipment.com)



**Moline Machinery LLC**

114 South Central Avenue • Duluth, Minnesota, USA, 55807  
218-624-5734 (For after hours service, call 218-590-1987)  
[www.moline.com](http://www.moline.com) • [sales@moline.com](mailto:sales@moline.com)



# Moline Frying Oil Filtration System



**Filter Connected to Fryer**

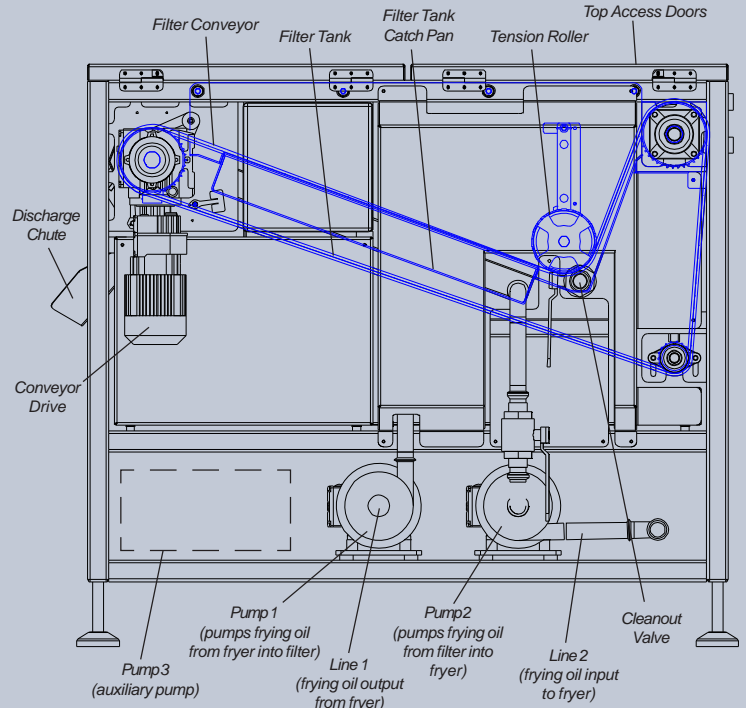

## Features

- **Construction:**  
Stainless steel construction with precision-machined components.

Wire mesh filtration conveyor with 60-micron filtration.
- **Control Functions:**  
Pump activation is easily controlled through the production system's operator interface.
- **Drive System:**  
Direct drive motor and gear reducer for the filter conveyor.
- **Electrical System:**  
Standard: 480 Volt, 60 Hertz, 3 Phase. Other options are available.
- **Integration:**  
Built for integration with existing frying systems.
- **Options:**  
Optional disposable filter paper provides 5 micron filtration.

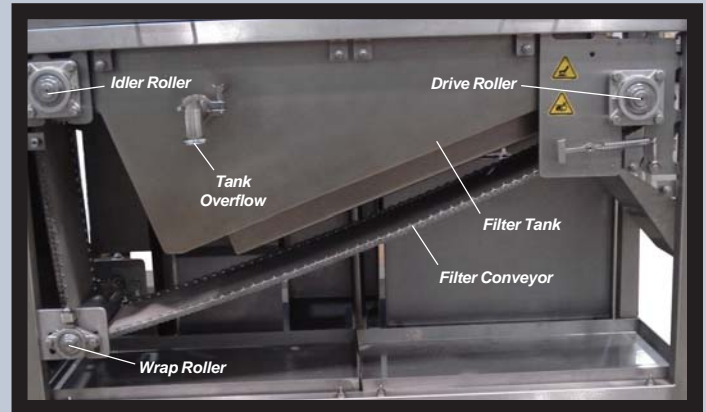

**Filtration Conveyor (side view inside guards)**

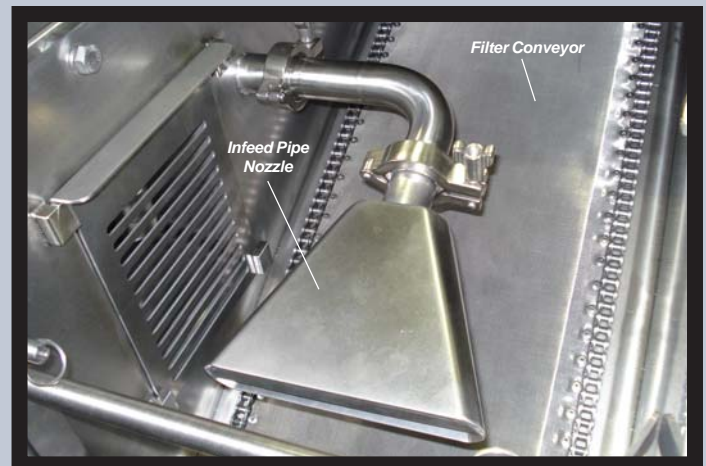

**Infeed Pipe Nozzle (interior view of filter tank)**