

Portable Mixers...



Packaging – Processing

Bid on Equipment

1-847-683-7720

www.bid-on-equipment.com

PORTABLE MIXERS...

Dedication to Quality...

MixMor continues to be a leading manufacturer of high quality, heavy duty portable mixers with more than 45 years of experience, offering a complete, diversified line of mixers to meet your process requirements. MixMor maintains a large inventory insuring on-time delivery. When it comes to "I need it today!", you can depend on MixMor. Same day shipments can normally be made.

The type of mixer recommended for your application is dependent upon the process requirements. Direct drive mixers are designed for low viscosity or small volume applications or applications requiring high shear. Gear drive mixers are effectively used on higher viscosity products or larger volume applications. Ranging from 1/4 to 5 horsepower, with seven standard speeds and a complete impeller selection, MixMor has the optimum mixer for your application.

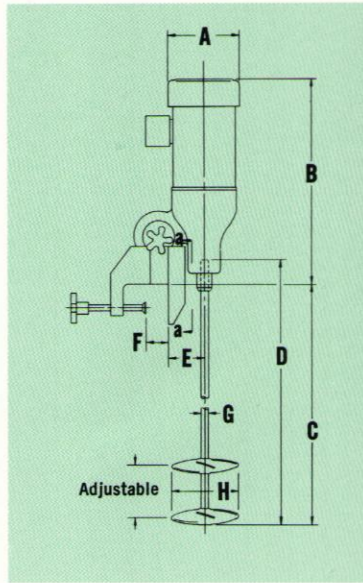

MODEL D • DIRECT DRIVE - ELECTRIC

Model	HP	Dimensions / Inches							H Dual Prop. Dia.	Weight, Pounds
		A	B	C	D	E	F	G		
D-14	1/4	6	17	35	36	3	3	5/8	3 1/2	34
D-13	1/3	6	17	35	36	3	3	5/8	4	35
D-12	1/2	7	20	46	48	3 3/4	3 3/4	5/8	4 1/2	52
D-34	3/4	7	21	46	48	3 3/4	3 3/4	5/8	5	55
D-11	1	7	21	58	60	3 3/4	3 3/4	7/8	6	85
D-15	1 1/2	9	21	58	60	3 3/4	3 3/4	7/8	6 1/2	112
D-2	2	9	23	58	60	3 3/4	3 3/4	7/8	7	123
D-3	3	11	24	58	60	3 3/4	3 3/4	1 1/4	7 1/2	159
D-5	5	11	25	58	60	3 3/4	3 3/4	1 1/4	7 1/2	182

Dimensions are approximate. Certified dimensional prints available upon request.

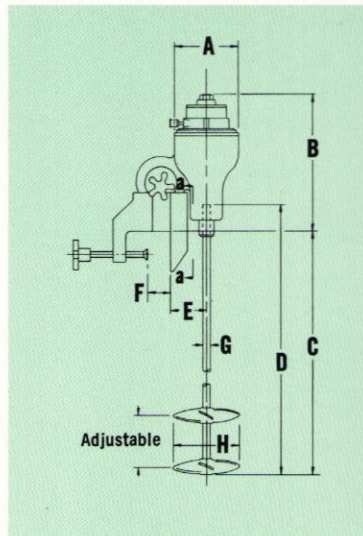
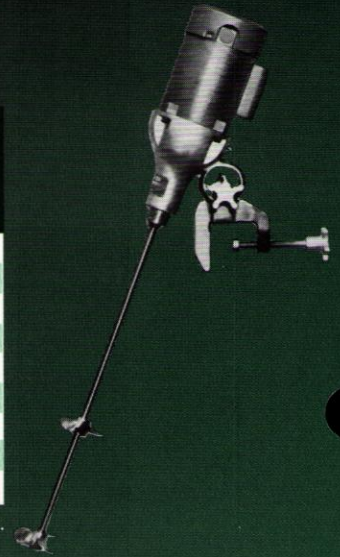

MODEL DA • DIRECT DRIVE - AIR

Model	HP	Dimensions / Inches							H Dual Prop. Dia.	Weight, Pounds
		A	B	C	D	E	F	G		
DA-13	1/3	6 1/2	12	35	36	3	3	5/8	3 1/2	34
DA-11	1	6 1/2	12	46	48	3	3	5/8	4	35
DA-2	2	6 1/2	16 1/2	58	60	3 3/4	3 3/4	7/8	4 1/2	52
DA-4	4	6 1/2	18	58	60	3 3/4	3 3/4	7/8	5	55

Dimensions are approximate. Certified dimensional prints available upon request.

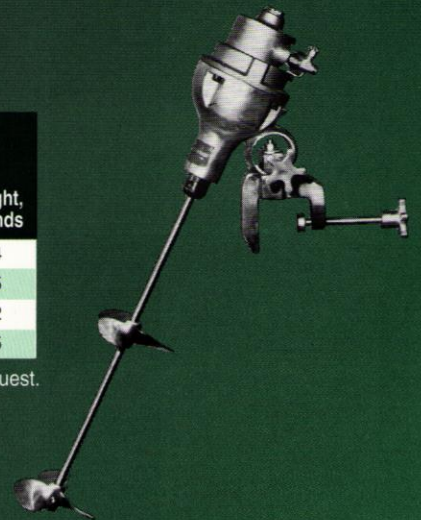

SECTION a-a CLAMP FACE

Dimensions / Inches

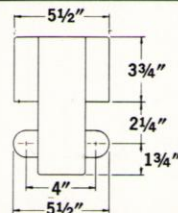

AS FURNISHED FOR:
Model D - 1 through 5 hp.
DA-2
DA-4
Model G - 1/2 through 5 hp.
Model GA - 1, 2, & 4

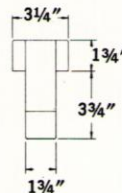

AS FURNISHED FOR:
Model D - 1/4 and 1/3 hp.
Model DA - 1/3 and 1 hp.

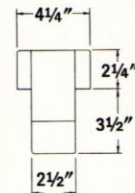

AS FURNISHED FOR:
Model G - 1/4 and 1/3 hp.
Model GA - 1/3 hp only.
Model D - 1/2 and 3/4 hp.

Features and Benefits...

Motors – Standard, commercially available, NEMA 'C' face motors in all enclosures and power requirements, also available with air motors.

Variable Speed Drives – Available with Inverter, AC variable frequency or Accumix® SCR/DC drives in NEMA 1 or 4 enclosures.

Housings – Aluminum alloy drive housings with heavy duty, corrosion resistant, brass clamps. Available in stainless steel or other alloys.

Gear Reducer – Helical gears with lifetime lubrication.

Impeller Speeds – Direct Drive... 1150, 1750 or 3450 rpm.
 Gear drive... 230, 290, 350, or 420 rpm.

Impeller Selection – FloMor High Efficiency Hydrofoils, Modified Propellers, Pitched Blade Turbines, ShearMor Disperser Disks, Folding and Custom Impellers.

Mounting – Clamp or cup base.

Options: • USDA accepted models • Stainless steel motors • Sanitary finishes • Coated shaft and impellers • All stainless steel mixers • Shaft and impellers in other alloys

MODEL G • GEAR DRIVE - ELECTRIC

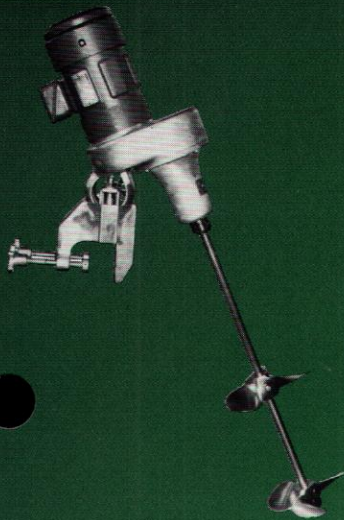

Model	HP	Dimensions / Inches						G Dual Prop. Dia.	Weight, Pounds
		A	B	C	D	E	F		
G-14	1/4	18	32	36	5/8	5 5/8	3 3/8	7	45
G-13	1/3	18	32	36	5/8	5 5/8	3 3/8	8	47
G-12	1/2	20	46	48	7/8	6 3/8	3 3/4	10	95
G-34	3/4	21	46	48	7/8	6 3/8	3 3/4	11	100
G-11	1	21	58	60	7/8	6 3/8	3 3/4	12	105
G-15	1 1/2	22	58	60	7/8	6 3/8	3 3/4	13	109
G-2	2	22	58	60	7/8	6 3/8	3 3/4	14	120
G-3	3	24	58	60	1 1/4	6 3/8	3 3/4	15	140
G-5	5	25	58	60	1 1/4	6 3/8	3 3/4	15	165

Dimensions are approximate. Certified dimensional prints available upon request.

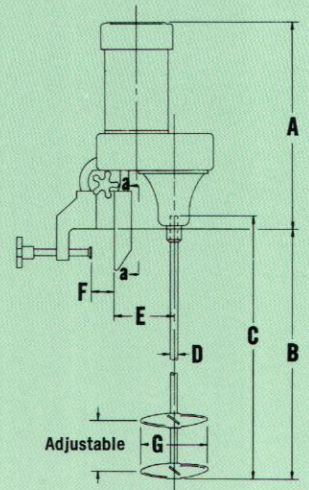

MODEL GA • GEAR DRIVE - AIR

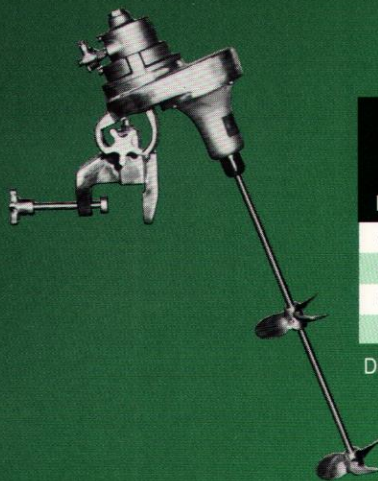

Model	HP	Dimensions / Inches						G Dual Prop. Dia.	Weight, Pounds
		A	B	C	D	E	F		
GA-13	1/3	14	32	36	5/8	5 5/8	3 3/8	8	45
GA-11	1	16	56	60	7/8	6 3/8	3 3/4	12	80
GA-2	2	16 1/2	58	60	7/8	6 3/8	3 3/4	14	95
GA-4	4	18	58	60	1 1/4	6 3/8	3 3/4	15	105

Dimensions are approximate. Certified dimensional prints available upon request.

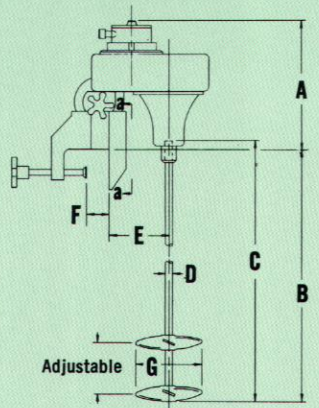

CUP BASE
 To Replace Clamp
Optional
 Dimensions / Inches

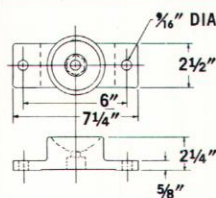

AS FURNISHED FOR:
 Model D – 1/4 and 1/3 hp.
 Model DA – 1/3 and 1 hp.

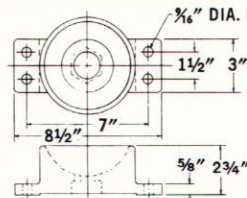

AS FURNISHED FOR:
 Model D – 1/2 through 5 hp.
 DA-2
 DA-4
 Model G – all units.
 Model GA – all units.

GUARANTEE

MECHANICAL

MixMor guarantees materials and workmanship of all products for one year from date of shipment.

PROCESS

All mixers are guaranteed for performance when their installation and use is in accordance with engineering recommendations made by MixMor.

FOR EVERY INDUSTRIAL APPLICATION

Laboratory Mixers

- Variable Speed
- Constant Speed
- Speed Ranges 2 to 6000 rpm
- Air and Electric
- Clamp and Stand Mounted

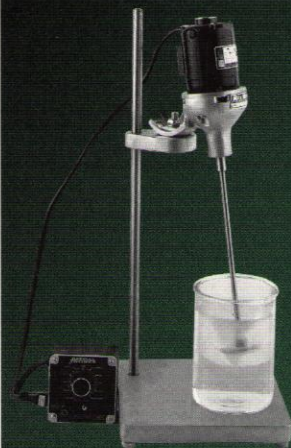

Portable Clamp-on Mixers

- 1/4 to 5 HP... Electric, Air and Hydraulic Motors
- Direct Drive... 1150 & 1750 rpm
- Gear Drive... 230, 290, 350 & 420 rpm
- Constant and Variable Speed
- Clamp & Cup Mounted
- USDA Accepted Designs

Fixed Mount-Top Entering Mixers

- 1/4 to 5 HP... Electric, Air and Hydraulic Motors
- Direct Drive... 1150 & 1750 rpm
- Gear Drive... 230, 290, 350 & 420 rpm
- Constant & Variable Speed
- Baseplate & Flange Mounted
- Low and High Pressure Stuffing Boxes
- Mechanical Seal Designs



MixMor

®

WEST COAST

3131 Casitas Avenue
Los Angeles, CA 90039
Tel: 213.664.1941
Fax: 213.660.5677

EAST COAST

801 Third Avenue
King of Prussia, PA 19406
Tel: 610.337.2700
Fax: 610.354.0937



Turbine Mixers

- 1/4 to 150 HP... Electric and Hydraulic Motors
- Constant & Variable Speed... 1 to 350 rpm
- Worm Gear, Helical/Worm... All Helical... Helical/Spiral Bevel
- Baseplate & Flange Mounted
- High & Low Pressure Stuffing Boxes;
- Single & Double Mechanical Seals

Side Entering Mixers

- Chemical & Petrochemical Plant Designs
- 1 to 75 HP... Electric & Hydraulic Motors
- Belt & Gear Drives... 280, 350 & 420 rpm
- Constant & Variable Speed
- Fixed & Swivel, Flange & Cover Plate Mounted
- Stuffing Box & Mechanical Shaft seals



Custom Mixers

- Pilot Plant Mixers
- High Temperature & Pressure Laboratory Reactors
- Redwood Paddle Flocculators
- Anchor, Ribbon & Gate Mixers
- Inline mixers
- Bottom Entering Mixers



NATIONAL REPRESENTATIVES

Your Local Representative Is:

Packaging - Processing
Bid on Equipment

1-847-683-7720

www.bid-on-equipment.com