

Fixed Mount Top Entering Mixers...

MixMOR®

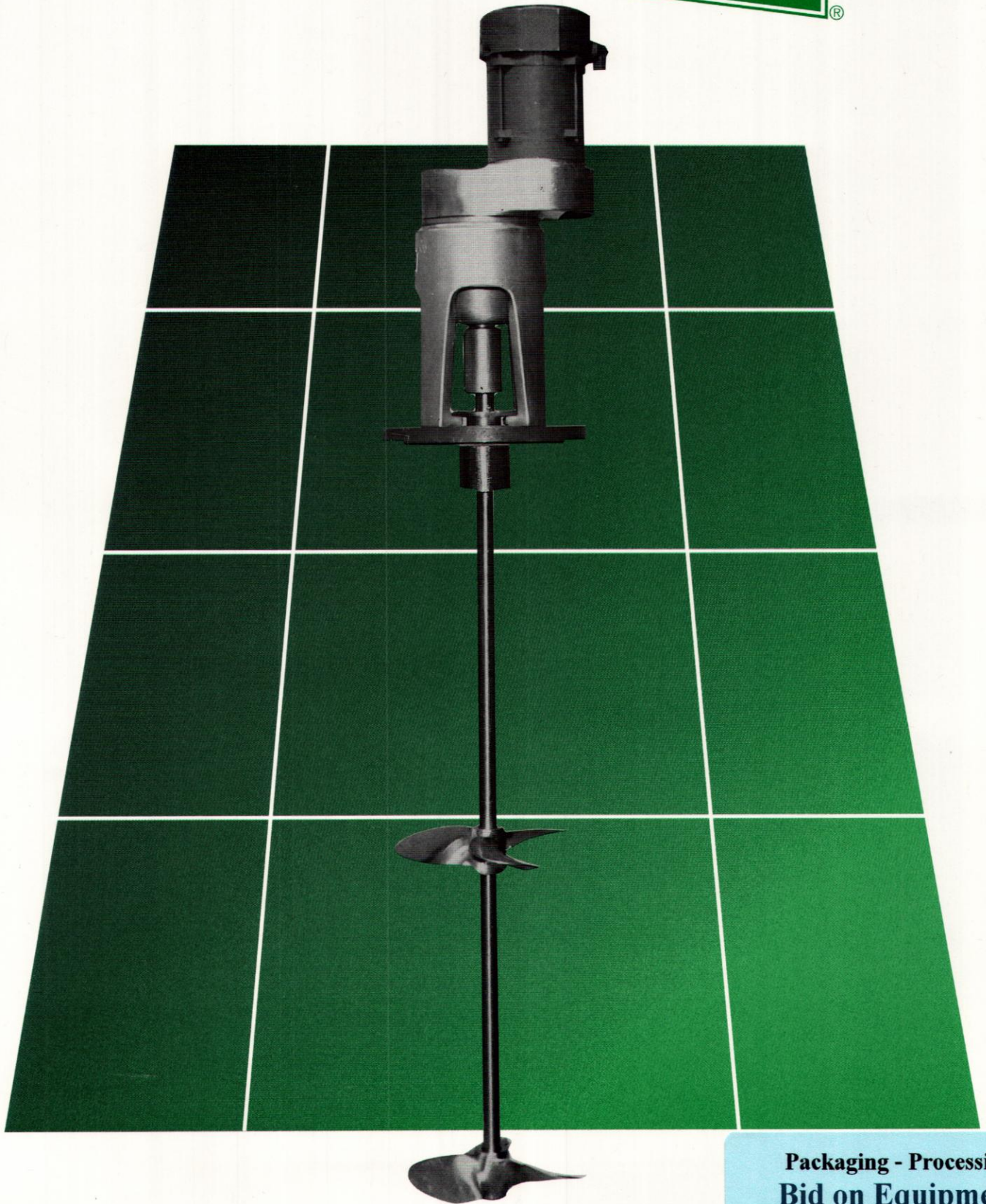

Packaging - Processing
Bid on Equipment

1-847-683-7720
www.bid-on-equipment.com

FIXED MOUNT TOP ENTERING MIXERS...

Dedicated to Quality...

MixMor continues to be a leading manufacturer of high quality, heavy duty, fixed mount top entering mixers with more than 45 years experience, offering a complete, diversified line of mixers to meet your process requirements. MixMor maintains a large inventory insuring on-time fast delivery. When it comes to "I need it today!", you can depend on MixMor to meet your schedule.

The type of mixer recommended for your application is dependent upon the process requirements. Direct drive mixers are designed for low viscosity or small volume applications or applications requiring high shear. Gear drive mixers are effectively used on higher viscosity products or larger volume applications. Ranging from 1/4 to 5 horsepower, with seven standard speeds and a complete impeller selection, MixMor has the optimum mixer for your application.

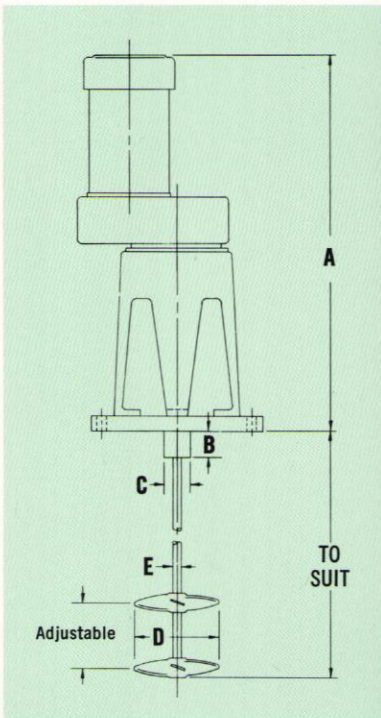

MODEL FG • GEAR DRIVE - FLANGE

Model	HP	Dimensions / Inches					Standard Flange, 150# Series	Weight, Pounds
		A	B	C	D Dual Prop. Diameter	E		
FG-14	1/4	22	2 1/4	2 1/2	7	5/8	5	69
FG-13	1/3	23	2 1/4	2 1/2	8	5/8	5	71
FG-12	1/2	28	3	3 1/4	10	1 1/4	8	150
FG-34	3/4	29	3	3 1/4	11	1 1/4	8	153
FG-11	1	29	3	3 1/4	12	1 1/4	8	160
FG-15	1 1/2	30	3	3 1/4	13	1 1/4	8	165
FG-2	2	30	3	3 1/4	14	1 1/4	8	172
FG-3	3	31	3	3 1/4	15	1 1/4	8	203
FG-5	5	32	3	3 1/4	15	1 1/4	8	215

Stuffing Boxes or Mechanical Seals...

Mixers can be furnished with high or low pressure stuffing box shaft seals rated for 150 and 10 PSIG as well as various types and manufacturers of mechanical seals including cartridge type double balanced, single and double dry running, metal bellows, tandem, water cooled, split and seals with sanitary containment glands.

Dimensions are approximate. Certified dimensional prints furnished upon request.

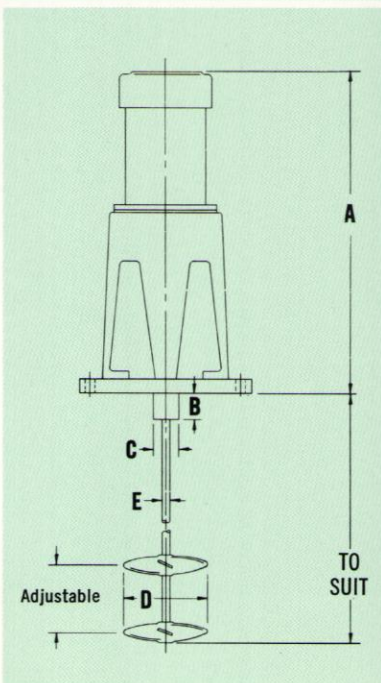

MODEL FD • DIRECT DRIVE - FLANGE

1/4 through 3/4 HP - 1750 RPM • 1 through 5 HP - 1160 RPM

Model	HP	Dimensions / Inches					Standard Flange, 150# Series	Weight, Pounds
		A	B	C	D Dual Prop. Diameter	E		
FD-14	1/4	18	2 1/4	2 1/2	3 1/2	5/8	5	60
FD-13	1/3	19	2 1/4	2 1/2	4	5/8	5	63
FD-12	1/2	21	2 1/4	2 1/2	4 1/2	7/8	8	82
FD-34	3/4	21	2 1/4	2 1/2	5	7/8	8	85
FD-11	1	22	3	3 1/4	6	1 1/4	8	131
FD-15	1 1/2	22	3	3 1/4	6 1/2	1 1/4	8	158
FD-2	2	24	3	3 1/4	7	1 1/4	8	169
FD-3	3	26	3	3 1/4	7 1/2	1 1/4	8	205
FD-5	5	27	3	3 1/4	7 1/2	1 1/4	8	228

Stuffing Boxes or Mechanical Seals...

Mixers can be furnished with the same seals as described above.

Dimensions are approximate. Certified dimensional prints furnished upon request.



Features and Benefits...

Motors – Standard, commercially available, NEMA 'C' face motors in all enclosures and power requirements, also available with air motors.

Variable Speed Drives – Available with Inverter, AC variable frequency or Accumix® SCR/DC drives in NEMA 1 or 4 enclosures.

Housings – Aluminum alloy drive housings. Available in stainless steel or other alloys.

Gear Reducer – Helical gears with lifetime lubrication.

Impeller Speeds – Direct Drive... 1150, 1750 or 3450rpm.
 Gear drive... 230, 290, 350, or 420 rpm.

Mounting – ANSI flanges with shaft seals, or baseplates.

Impeller Selection – FloMor High Efficiency Hydrofoils, Modified Propellers, Pitched Blade Turbines, ShearMor Disperser Disks, Folding and Custom Impellers.

Options: • Stainless steel motors • Sanitary finishes • Coated shaft and impellers • All stainless steel mixers • Shaft and impellers in other alloys

MODEL OG GEAR DRIVE • BASEPLATE

Dimensions are approximate. Certified dimensional prints furnished upon request.

Model	HP	Dimensions / Inches			Weight, Pounds
		C	D	E Dual Prop. Dia.	
OG-14	1/4	22	5/8	7	60
OG-13	1/3	23	5/8	8	63
OG-12	1/2	28	1 1/4	10	119
OG-34	3/4	29	1 1/4	11	121
OG-11	1	29	1 1/4	12	129
OG-15	1 1/2	30	1 1/4	13	134
OG-2	2	30	1 1/4	14	141
OG-3	3	31	1 1/4	15	172
OG-5	5	32	1 1/4	15	184

CHOICE OF MOUNTING FOR MODELS OG AND OD (REFER TO MODEL OG DRAWING FOR LOCATION)

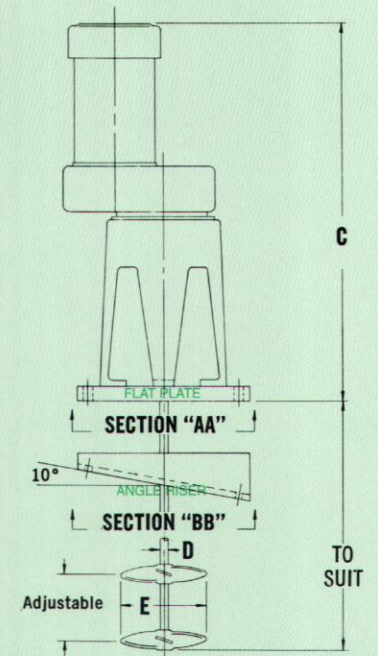
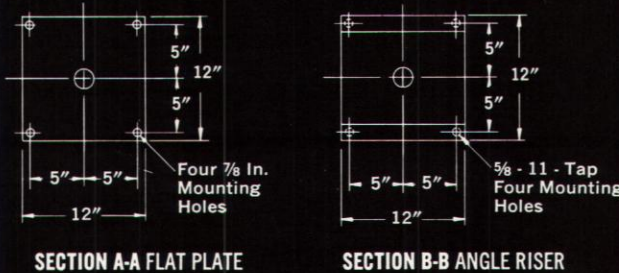

MODEL OD DIRECT DRIVE • BASEPLATE

1/4 through 3/4 HP - 1750 RPM
 1 through 5 HP - 1160 RPM

Dimensions are approximate. Certified dimensional prints furnished upon request.

Model	HP	Dimensions / Inches			Weight, Pounds
		A	B	C Dual Prop. Dia.	
OD-14	1/4	18	5/8	3 1/2	53
OD-13	1/3	19	5/8	4	55
OD-12	1/2	21	7/8	4 1/2	63
OD-34	3/4	21	7/8	5	66
OD-11	1	22	1 1/4	6	100
OD-15	1 1/2	22	1 1/4	6 1/2	137
OD-2	2	24	1 1/4	7	148
OD-3	3	26	1 1/4	7 1/2	184
OD-5	5	27	1 1/4	7 1/2	207

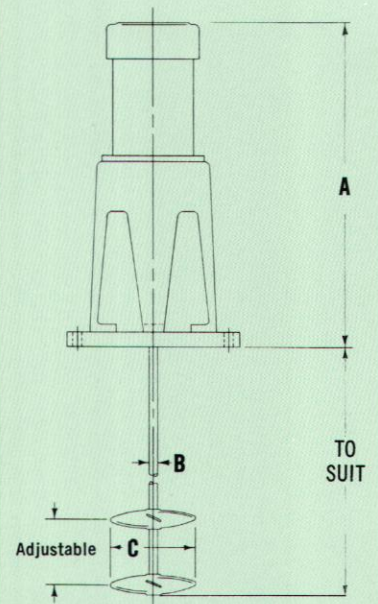

GUARANTEE

MECHANICAL

MixMor guarantees materials and workmanship of all products for one year from date of shipment.

PROCESS

All mixers are guaranteed for performance when their installation and use is in accordance with engineering recommendations made by MixMor.

FOR EVERY INDUSTRIAL APPLICATION

Laboratory Mixers

- Variable Speed
- Constant Speed
- Speed Ranges 2 to 6000 rpm
- Air and Electric
- Clamp and Stand Mounted

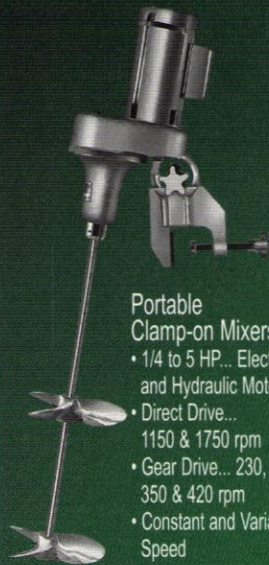
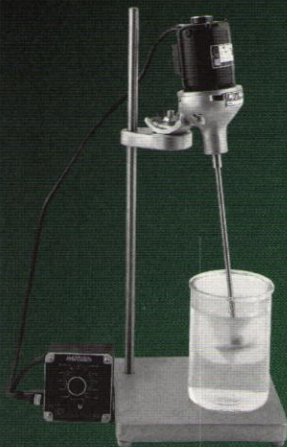

Portable Clamp-on Mixers

- 1/4 to 5 HP... Electric, Air and Hydraulic Motors
- Direct Drive... 1150 & 1750 rpm
- Gear Drive... 230, 290, 350 & 420 rpm
- Constant and Variable Speed
- Clamp & Cup Mounted
- USDA Accepted Designs

Fixed Mount-Top Entering Mixers

- 1/4 to 5 HP... Electric, Air and Hydraulic Motors
- Direct Drive... 1150 & 1750 rpm
- Gear Drive... 230, 290, 350 & 420 rpm
- Constant & Variable Speed
- Baseplate & Flange Mounted
- Low and High Pressure Stuffing Boxes
- Mechanical Seal Designs



MixMor

®

WEST COAST

3131 Casitas Avenue
Los Angeles, CA 90039
Tel: 213.664.1941
Fax: 213.660.5677

EAST COAST

801 Third Avenue
King of Prussia, PA 19406
Tel: 610.337.2700
Fax: 610.354.0937



Turbine Mixers

- 1/4 to 150 HP... Electric and Hydraulic Motors
- Constant & Variable Speed... 1 to 350 rpm
- Worm Gear, Helical/Worm... All Helical... Helical/Spiral Bevel
- Baseplate & Flange Mounted
- High & Low Pressure Stuffing Boxes
- Single & Double Mechanical Seals

Side Entering Mixers

- Chemical & Petrochemical Plant Designs
- 1 to 75 HP... Electric & Hydraulic Motors
- Belt & Gear Drives... 280, 350 & 420 rpm
- Constant & Variable Speed
- Fixed & Swivel, Flange & Cover Plate Mounted
- Stuffing Box & Mechanical Shaft seals



Custom Mixers

- Pilot Plant Mixers
- High Temperature & Pressure Laboratory Reactors
- Redwood Paddle Flocculators
- Anchor, Ribbon & Gate Mixers
- Inline mixers
- Bottom Entering Mixers



NATIONAL REPRESENTATIVES

Your Local Representative Is:

Packaging - Processing
Bid on Equipment

1-847-683-7720

www.bid-on-equipment.com