

XL Mixers

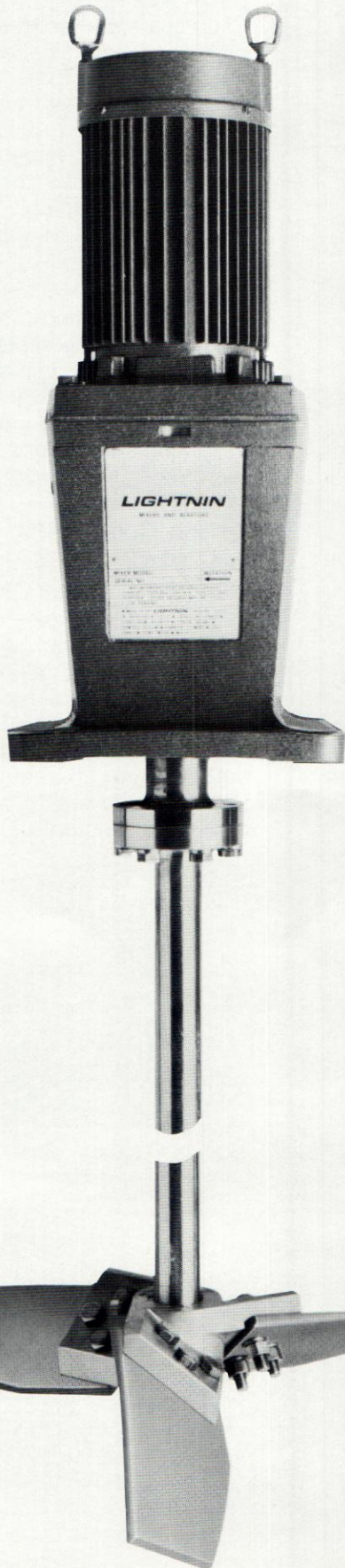

DURA-MIX™ HIGH EFFICIENCY MOTORS.

Available 1 to 5 hp. Bearings are lubricated for life.
Explosion proof model available.

CHANGE GEARS.

You can readily change speeds as process requirements change, by simply changing gears.

LUBRICATED FOR LIFE.

Double reduction gears and bearings are grease lubricated for life.

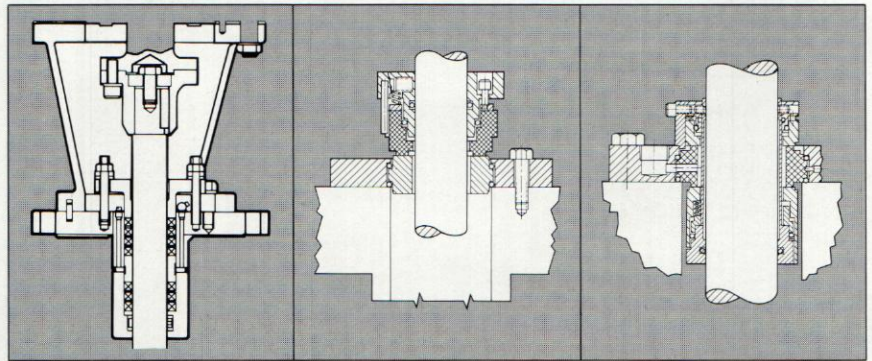

MODEL XLC.
Standard stuffing box is for closed tanks up to 150 psig.

MODEL XLSS.
New mechanical seals can operate dry or with liquid lubrication.

MODEL XLDS.

RIGID COUPLING.

Is standard and makes for easy installation of lower shaft and turbine.

HIGH FLOW HIGH EFFICIENCY A310 IMPELLERS.

Large diameter impellers assure high pumping action. Available in single or dual configuration. Materials available: Steel, 316SS, Hastelloy C.

ANGLE RISERS ELIMINATE BAFFLES.

Optional angle risers provide angular off-center mounting so that baffles are not needed in open tanks. This means savings of up to 10% on stainless steel tanks and up to 15% on fiberglass tanks.

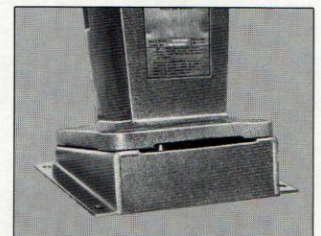

FOR DEEP TANKS.

Shafts can range up to 15', depending on hp, rpm, and impellers.

For additional details, ask for Bulletin B-581.

Packaging - Processing Bid on Equipment

1-847-683-7720

www.bid-on-equipment.com

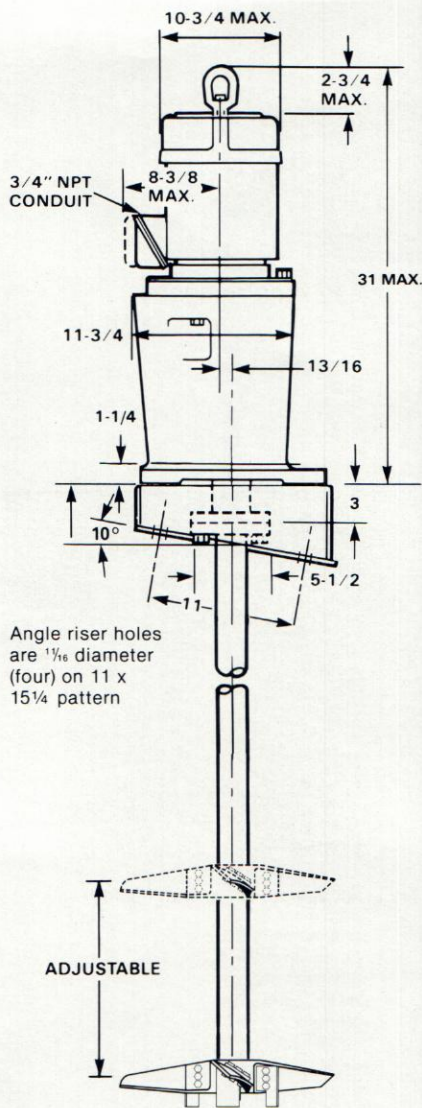

Angle riser holes are 1/16 diameter (four) on 11 x 15 1/4 pattern

XLQ for open tanks.

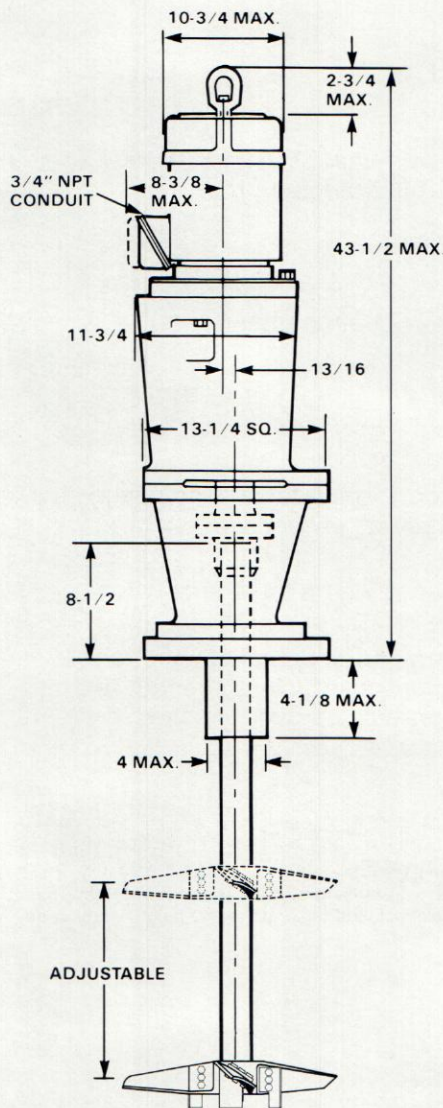

XLC with standard stuffing box for closed tanks up to 150 psig.

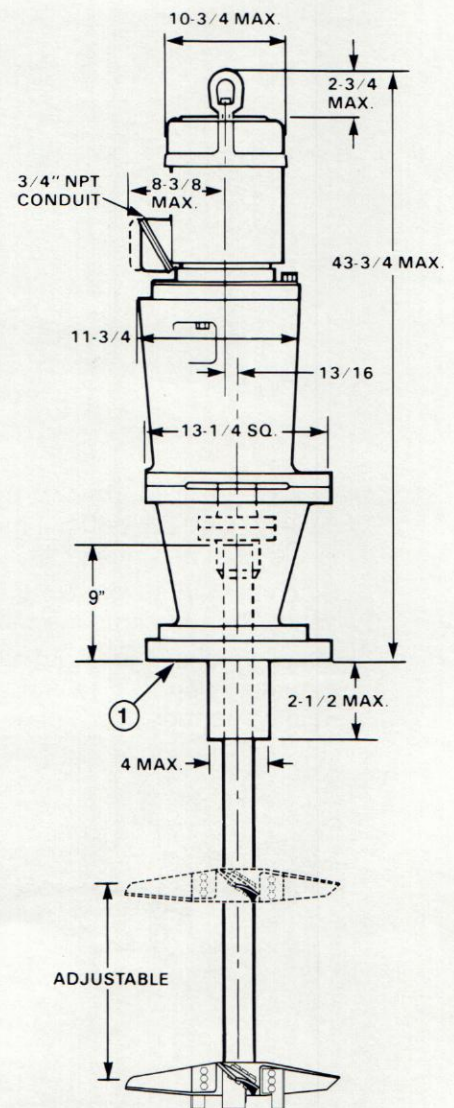

XLSS with single mechanical seal for closed tanks.
XLDS with double mechanical seal for closed tanks.
1) Standard mounting flange 150 lb. 8" ANSI (ASA) series drilling.

XL MIXERS

MODEL XLQ

MODEL	HP	BASIC MIXER WEIGHT - LBS	TOTAL MIXER WGT	
			SINGLE IMPELLER	DUAL IMPELLERS
XL Q-100B	1.0	186	312	328
XL Q-100D			340	354
XL Q-100F			372	400
XL Q-100H			420	468
XL Q-150B	1.5		313	330
XL Q-150D			340	364
XL Q-150F			373	388
XL Q-200B	2.0	190	317	334
XL Q-200D			345	348
XL Q-200F			369	375
XL Q-300B	3.0	195	323	341
XL Q-300C			345	360
XL Q-500A	5.0	200	329	N.R.

MODEL XLC

MODEL	HP	BASIC MIXER WEIGHT - LBS	TOTAL MIXER WGT	
			SINGLE IMPELLER	DUAL IMPELLERS
XL C-100B	1.0	290	413	429
XL C-100D			441	455
XL C-100F			473	501
XL C-100H			521	569
XL C-150B	1.5		414	431
XL C-150D			441	465
XL C-150F			474	489
XL C-200B	2.0	294	418	435
XL C-200D			446	460
XL C-200F			470	487
XL C-300B	3.0	299	424	442
XL C-300C			446	472
XL C-500A	5.0	305	431	N.R.

MODELS XLSS, XLDS

MODEL	HP	BASIC MIXER WEIGHT - LBS	TOTAL MIXER WGT	
			SINGLE IMPELLER	DUAL IMPELLERS
XLSS & XLDS-100B	1.0	300	423	439
XLSS & XLDS-100D			451	465
XLSS & XLDS-100F			483	511
XLSS & XLDS-100H			531	579
XLSS & XLDS-150B	1.5		524	441
XLSS & XLDS-150D			451	475
XLSS & XLDS-150F			484	499
XLSS & XLDS-200B	2.0	304	428	445
XLSS & XLDS-200D			456	470
XLSS & XLDS-200F			480	497
XLSS & XLDS-300B	3.0	309	434	452
XLSS & XLDS-300C			456	482
XLSS & XLDS-500A	5.0	315	440	N.R.