

LIGHTNIN heavy duty, high flow mixers

Packaging - Processing
Bid on Equipment

1-847-683-7720

www.bid-on-equipment.com

XJ Series

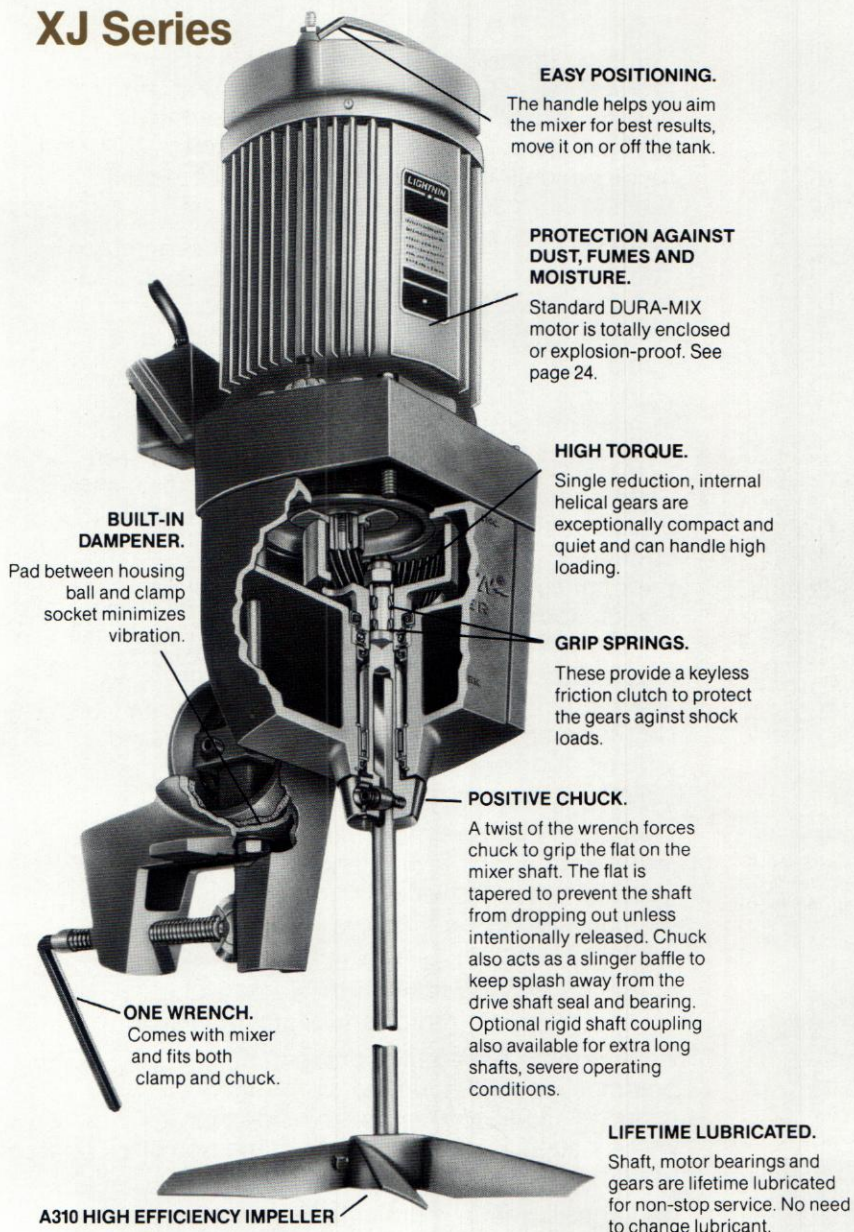

EASY POSITIONING.

The handle helps you aim the mixer for best results, move it on or off the tank.

PROTECTION AGAINST DUST, FUMES AND MOISTURE.

Standard DURA-MIX motor is totally enclosed or explosion-proof. See page 24.

HIGH TORQUE.

Single reduction, internal helical gears are exceptionally compact and quiet and can handle high loading.

GRIP SPRINGS.

These provide a keyless friction clutch to protect the gears against shock loads.

POSITIVE CHUCK.

A twist of the wrench forces chuck to grip the flat on the mixer shaft. The flat is tapered to prevent the shaft from dropping out unless intentionally released. Chuck also acts as a slinger baffle to keep splash away from the drive shaft seal and bearing. Optional rigid shaft coupling also available for extra long shafts, severe operating conditions.

LIFETIME LUBRICATED.

Shaft, motor bearings and gears are lifetime lubricated for non-stop service. No need to change lubricant.

BUILT-IN DAMPENER.

Pad between housing ball and clamp socket minimizes vibration.

ONE WRENCH.

Comes with mixer and fits both clamp and chuck.

A310 HIGH EFFICIENCY IMPELLER

EASY SET-UP.

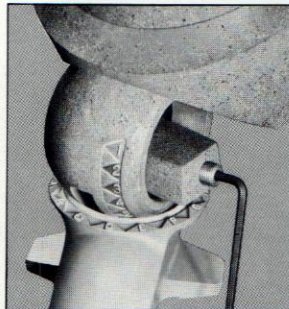

Standard clamp securely mounts to tank rim or other support. Mixer adjusts 90° vertically, 360° horizontally for optimal positioning and repositioning. Indexed ball and socket let you repeat settings exactly.

CUP MOUNT OPTION.

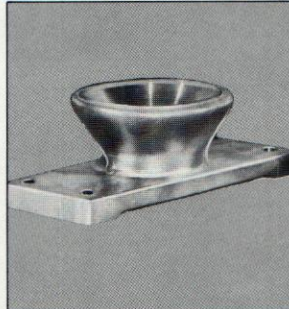

Lets you permanently mount mixer, yet retain vertical and horizontal movement with indexing feature.

Our most popular portables

Tens of thousands of these green Lightnin mixers are at work, delivering guaranteed results around the world. Many are original units, first built in 1960.

Gear drive, high flow Lightnin mixers with A310 Impellers produce a powerful action which sweeps the tank bottom and produces rapid top to bottom turnover.

For more jobs than not, the result is lower cost and less horsepower to do the job.

HIGH VISCOSITY.

The high torque delivered by internal gearing is essential for mixing heavy liquids like mayonnaise and molasses and fluids in the 15,000 to 100,000 centipoise range.



For mixing ceramic slips and plaster, for preparing sand for foundry cores and molds, for all manner of slurry and high viscosity mixing.



High flow units mix soup and spaghetti sauce, cake and cookie batter, relish and catsup, and the list goes on and on.



Manufacturers make Lightnin gear drives a part of packaged unit processes, as in this polymer make-up system.

CLAMP MOUNT

Packaging - Processing
Bid on Equipment

1-847-683-7720

www.bid-on-equipment.com

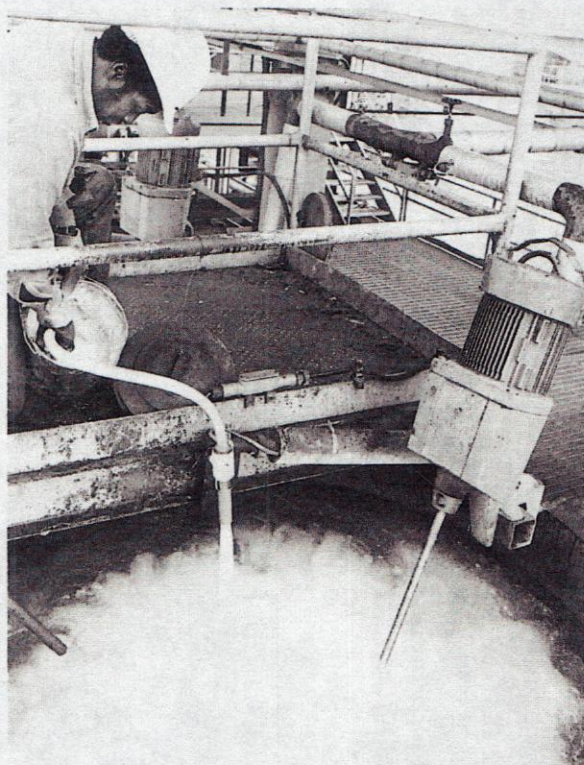

High flow mixers provide non-stop service in the processing of mineral slurries and other industrial applications.

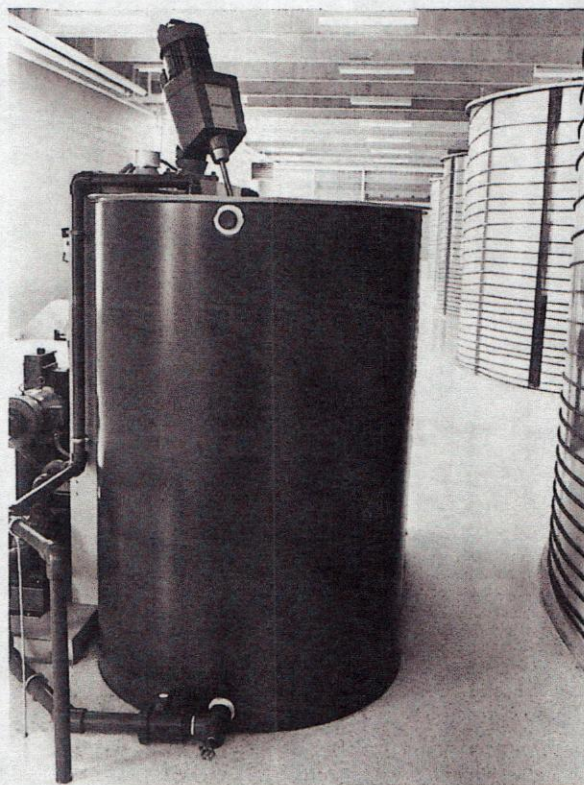

You'll find Lightnin portables making up solutions as diverse as auto wax and chemicals for wastewater treatment.

LARGE BATCHES.

The high torque is very effective in handling low-viscosity fluids in large batches that are beyond the range of direct drive units. Soft drink bottlers, for example, use Lightnin mixers widely for making up syrup in batches ranging from 300 to 6000 gallons.

FOUNDRIES.

These heavy-duty workhorses prepare sand for cores and molds. They mix various washes. They assist circulation of fluids in metal quenching. You'll even find them working in molten metal to help fluxes remove impurities.

DAIRIES.

Lightnin high flow portables prevent rising of cream in storage tanks. They maintain circulation in pasteurizers. They achieve uniformity in ice cream mix and chocolate drinks, and do all manner of other work in the dairy. Your Lightnin sales representative has a selection table covering both high flow and high shear mixers, especially for dairies. Call for a specification for your tank, your volume and your process.

HIGH TEMPERATURES.

You'll find Lightnin mixers at work in molten metal and in tanks for quenching and heat-treating metal as well as in other high temperature applications.

A variety of modifications is available to suit operating temperatures in the tank, and around the mixer motor and housing.

Among them are special grease and bearings, special coupling construction, oversize shafts with impeller welded on, as well as special motor insulation and housing materials.

Call your Lightnin representative for specific recommendations to suit your application.



Gear drive portables deliver high flow, high pumping action in wash and treatment tanks for metal parts.

CLAMP
MOUNT

Standard materials and equipment

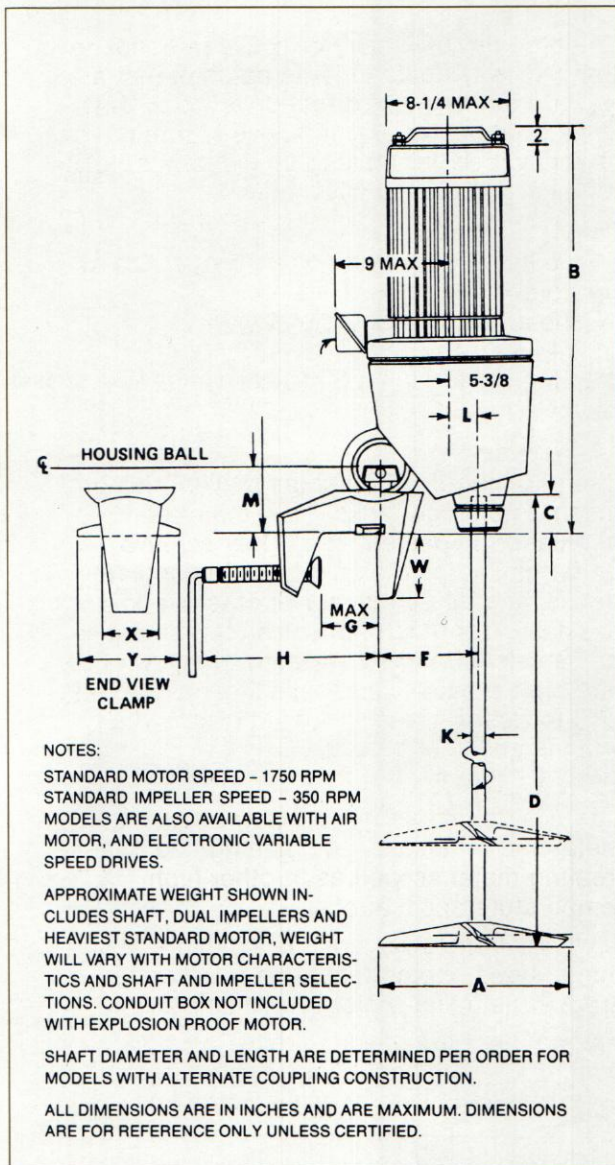

XJ Series

Mixer Housing — Aluminum*

Chuck or Rigid Coupling—Electroless nickel plated steel or steel rigid coupling. Both are available in 316SS as an option.

Clamp — Aluminum*

Shaft and Impellers — Steel or 316 stainless. Also available in any wrought commercial alloys and with coverings of such materials as rubber, PVC, polymers and fluorocarbons.

Paint — Styrenated alkyd enamel, 400 hours minimum salt spray resistance. Electroless nickel plated finish optional.

*Other materials available

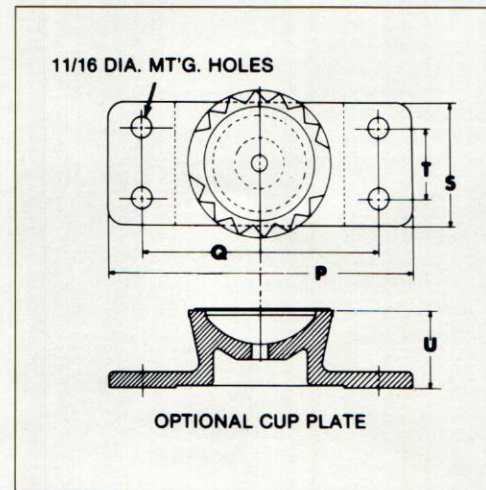

CLAMP MOUNT

HEAVY DUTY, HIGH FLOW GEAR DRIVES

Model	Wgt	A Impeller Dia.		B	C	D	E	F	G	H	K	L	M	P	Q	R	S	T	U	W	X	Y	Z
		Single	Dual																				
XJ-30	65	11.2	10.0	21	3 ⁷ / ₈	36	3 ⁷ / ₈	5	3	9	5 ⁸ / ₁₆	1 ³ / ₈	3 ⁷ / ₁₆	9	7	3 ⁸ / ₁₆	3 ¹ / ₂	2	2 ¹ / ₄	3 ¹ / ₈	2 ³ / ₈	5 ³ / ₁₆	3 ⁸ / ₁₆
XJ-43	70	11.8	11.2	21	3 ⁷ / ₈	36	3 ⁷ / ₈	5	3	9	5 ⁸ / ₁₆	1 ³ / ₈	3 ⁷ / ₁₆	9	7	3 ⁸ / ₁₆	3 ¹ / ₂	2	2 ¹ / ₄	3 ¹ / ₈	2 ³ / ₈	5 ³ / ₁₆	3 ⁸ / ₁₆
XJ-65	86	13.6	11.8	22 ⁷ / ₈	4 ⁷ / ₈	48	4 ³ / ₄	5 ¹ / ₂	3 ³ / ₄	11	3 ⁴ / ₁₆	1 ⁵ / ₈	4 ³ / ₁₆	10	8 ¹ / ₂	0	3 ⁵ / ₈	2	2 ⁷ / ₁₆	3 ¹ / ₂	2 ⁷ / ₈	5 ³ / ₄	1 ¹ / ₂
XJ-87	95	15.1	12.8	22 ⁷ / ₈	4 ⁷ / ₈	48	4 ³ / ₄	5 ¹ / ₂	3 ³ / ₄	11	3 ⁴ / ₁₆	1 ⁵ / ₈	4 ³ / ₁₆	10	8 ¹ / ₂	0	3 ⁵ / ₈	2	2 ⁷ / ₁₆	3 ¹ / ₂	2 ⁷ / ₈	5 ³ / ₄	1 ¹ / ₂
XJ-117	100	15.6	13.6	23 ¹ / ₈	4 ⁷ / ₈	48	4 ³ / ₄	5 ¹ / ₂	3 ³ / ₄	11	3 ⁴ / ₁₆	1 ⁵ / ₈	4 ³ / ₁₆	10	8 ¹ / ₂	0	3 ⁵ / ₈	2	2 ⁷ / ₁₆	3 ¹ / ₂	2 ⁷ / ₈	5 ³ / ₄	1 ¹ / ₂
XJ-174	125	17.0	15.1	26 ⁵ / ₈	4 ⁵ / ₈	60	4 ³ / ₄	6 ¹ / ₂	3 ³ / ₄	12	7 ⁸ / ₁₆	1 ⁷ / ₈	4 ¹ / ₂	10	8 ¹ / ₂	5 ⁸ / ₁₆	4	2 ¹ / ₂	2 ¹ / ₄	4 ³ / ₁₆	3 ¹ / ₄	6 ⁷ / ₈	1 ¹ / ₂
XJ-230	135	18.0	15.6	28 ³ / ₈	4 ⁵ / ₈	60	4 ³ / ₄	6 ¹ / ₂	3 ³ / ₄	12	7 ⁸ / ₁₆	1 ⁷ / ₈	4 ¹ / ₂	10	8 ¹ / ₂	5 ⁸ / ₁₆	4	2 ¹ / ₂	2 ¹ / ₄	4 ³ / ₁₆	3 ¹ / ₄	6 ⁷ / ₈	1 ¹ / ₂
XJ-350	140	19.0	17.0	28 ³ / ₈	4 ⁵ / ₈	60	4 ³ / ₄	6 ¹ / ₂	3 ³ / ₄	12	7 ⁸ / ₁₆	1 ⁷ / ₈	4 ¹ / ₂	10	8 ¹ / ₂	5 ⁸ / ₁₆	4	2 ¹ / ₂	2 ¹ / ₄	4 ³ / ₁₆	3 ¹ / ₄	6 ⁷ / ₈	1 ¹ / ₂

**Packaging - Processing
 Bid on Equipment**

1-847-683-7720

www.bid-on-equipment.com