

M-210EH Series

Electric-Hydraulic Microfluidizer Pilot Scale Equipment
for Continuous High Shear Fluid Processing-Pilot Plant Scale

Pilot Scale Microfluidizer[®] Processors - Models A, B and C

Recommended for:

- *Immiscible Liquid Emulsions*
- *Solids in Liquid Suspensions*
- *Sub-Micron Particle Size Reduction*
- *Cell Disruption*
- *Deagglomeration*

The M-210EH Series A, B and C Microfluidizer Processors are pilot-scale machines that provide the highest shear rates of all available mixers and homogenizers on the market today. Three models are available to provide the user with a broad choice of operating pressures and product flow rates. The M-210EH series machines maximize the energy-per-unit fluid volume, resulting in uniform submicron particle and droplet sizes.

Using Microfluidics' fixed-geometry interaction chamber technology, each M-210EH model is easy to operate, and is capable of processing a wide variety of fluids ranging from simple oil-in-water emulsions to highly abrasive solid-in-liquid suspensions.

The M-210EH machines are also highly efficient in deagglomeration and cell disruption.



The M-210EH Series Microfluidizer processors combine superior, scalable results with easy handling and cleaning

Key benefits:

- Repeatable, uniform results with guaranteed scale-up to full production
- Maximum product yield — continuous or batch mode. The model M-210EH can produce up to 1.5 gpm

Key features:

- Double-acting intensifier pump provides near-perfect pressure profile for repeatable results
- Patented, wear-resistant interaction chamber technology maximizes energy per unit volume of product
- The M-210EH machines are also highly efficient in deagglomeration and cell disruption
- Highest shear rates of all available mixers and homogenizers
- Easy in-line cleaning and simple maintenance



Patented Microfluidizer process produces uniform dispersions with submicron size particles

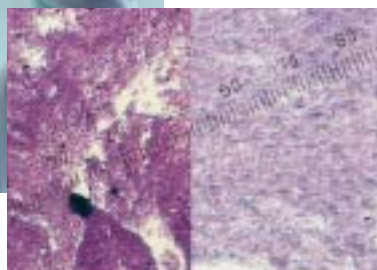

Before processing After processing

 **Microfluidics[™]**

DIVISIONS OF **MFIC**
CORPORATION

Guaranteed scaleup

The Microfluidizer process equipment line is unique in the fluid processing industry in using the same interaction chamber technology throughout our line from laboratory to high-volume production models. This enables Microfluidics to guarantee that results you have obtained in your R&D are reproducible in higher volume production.

In addition, Microfluidics is a service-oriented vendor; we will assist in helping you determine your preferential flow and pressure rates, and work with you in sampling your formulas in our applications laboratory, providing full confidential documentation of results. You will receive qualitative and quantitative analysis, particle size measurement and distribution results, and recommendations on how to achieve desired results.

We work as your partner in product development and production, providing out-of-house expertise and ongoing applications assistance.

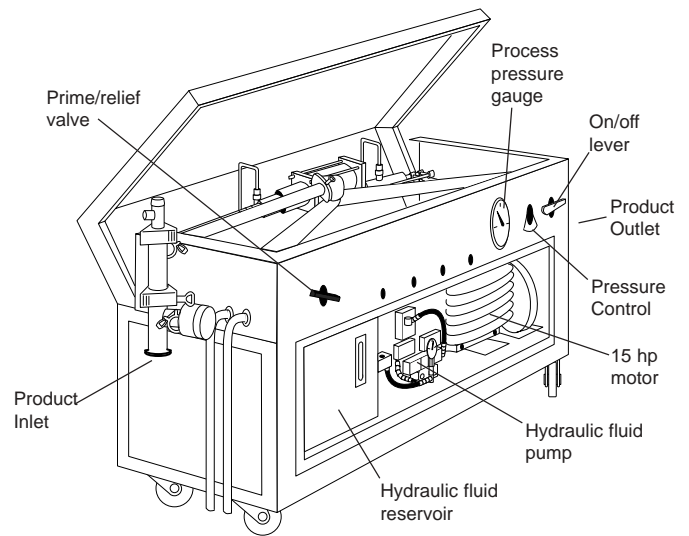

Operating principle

Each M-210EH series machine contains an on-board 15 horsepower electric-hydraulic module that provides power to a double-acting intensifier pump. The intensifier pump amplifies the hydraulic pressure and, in turn, imparts that pressure to the product stream. Process pressures ranging from 2,500 up to 30,000 psi may be selected with the simple turn of a knob.

The intensifier pump is designed to supply the desired pressure at a constant rate to the product stream. As the pump travels in one direction, it drives the product at constant pressure through the interaction chamber. Within the chamber are specially designed fixed geometry micro-channels through which the product accelerates to high velocities, creating shear and impact forces as the product stream impinges upon itself and on wear-resistant surfaces, bringing about the desired results.

As the intensifier pump continues its travel in one direction, a series of check valves allow product to be drawn into the opposite end of the pump. As the intensifier pump completes its stroke, it reverses direction and the new volume of product is pressurized repeating the process. This creates a constant flow of product at near constant pressure through the interaction chamber.

Upon exiting the interaction chamber, the product may be directed through an optional heat exchanger, recirculated through the system for further processing or directed externally to the next step in the process, bringing about the desired results.

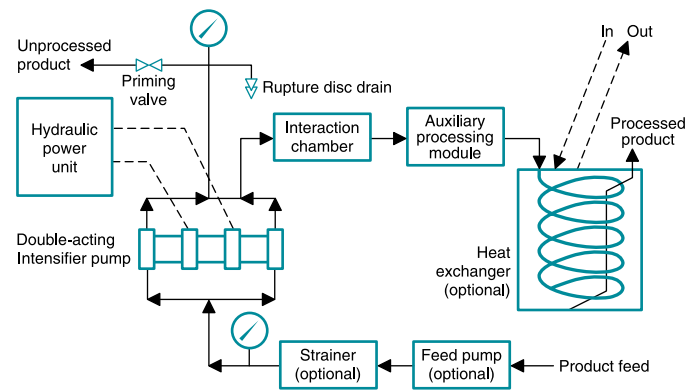

Interaction chamber choices



The interaction chamber is a patented device which allows you to achieve formulations with characteristics that would not be possible or economical with other available techniques. Interaction chambers are of fixed internal geometries through which materials are processed at extreme pressures (up to 40,000* psi) and velocities creating shear rates that are orders of magnitude greater than any other conventional means. All of the product experiences identical processing conditions resulting in uniform, sub-micron particle and droplet sizes, effective deagglomeration and highly efficient cell disruption.

*40kpsi is achievable with M-140K, M-700, and M-610 Series Microfluidizer processors.

| Sample | Pressure | Passes | Results |
|---|--|--|---|
| EMULSIONS Oil-in-water emulsion 10% Mineral Oil, 1% HLB 12 in water Cellulose Fibers Ketchup | 10,000 psi 20,000 psi 2,000 psi | 1 pass 3 passes 1 pass | Small, uniform particle distribution (175 nm +/- 37%) resulting in long-term stability. Formed a thick, creamy emulsion. Increased viscosity. Resulted in smoother, more homogenous ketchup with improved mouth feel, greater yield. |
| DISPERSIONS Dispersion of steroids/water Cosmetic Color Dispersion 30% Iron Oxides (Fe ₃ O ₄) in solvent Phthalocyanine pigment (blue) in polymer and solvent Gasket Material: Carbon Black and rubber in MEK and other solvents | 22,000 psi 19,500 psi 10,000 psi 15,000 psi 18,000 psi | 6 passes 1 pass 1 pass 3 passes 4 passes | Starting size 0-100 microns. Achieved average particle size of 0-2 microns. Reduced particle size, increased uniformity and enhanced color intensity. Total deagglomeration in one pass for magnetic coating. Continuous process. Deagglomerated and dispersed polymer/pigment uniformly in solvent. Replaced media mill; easy to operate and clean with no media contamination. Produced better, smoother dispersion for making gasket compound. |
| LIPOSOMES Diagnostic Liposomes 300 u.mo/ml Phosphatidylcholine and Cholesterol Cosmetic Liposomes 11% Soy Lecithin with Amino Acids | 5,000 psi 18,000 psi | 1 pass 1 pass | Ability to process a very viscous, high concentration of liposomes continuously to achieve a size distribution of 161 nm +/- 40%. Current method used to process a commercial product with a resulting particle size of 71 nm +/- 31%. |
| CELL-DISRUPTION <i>E coli</i> | 11,000 psi | 1 pass | Achieved 90%+ rupture rate while maintaining the process temperature at 15°C. |

Standard features

- Dimensionally Fixed Interaction Chamber Employs No Moving Parts — abrasion resistant ceramic or diamond construction.
- Highly Durable Intensifier Pumping System — efficient at ultrahigh pressures.
- High Pressure Plunger Seals and Check Valves — made to withstand abrasive and corrosive formulations. Both seals and check valves are accessible and can be replaced easily.
- Isolation Of The Process Fluid From The Hydraulic Fluid — prevents cross contamination.
- Coned and threaded tubing and fittings — these connections provide a high degree of reliability and cleanability.
- Stainless Steel Frame and Enclosure — protects the high pressure components from damage, contains spills and features panels which are easily removable.
- Components Rated For Maximum Working Pressure of the Machine.
- Simple and Efficient Fluid Power Drive System.
- Materials of Construction — wetted parts of: 316S.S., Tungsten Carbide, alumina (Al₂O₃), Ultra high molecular weight polyethylene (UHMWPE), Teflon® (PTFE), polyetheretherketone (PEEK), 17.4 PH S.S., Nitronic 60, 15.5 PH S.S.

Equipment options

- Plunger Seals — Teflon® (PTFE) seals are available for high temperatures of up to 300°F
- Outlet heat exchanger
- Chamber Sets — additional sets of interaction chambers are available in different sizes or diamond interiors to suit application requirements
- Steam sterility package
- Ultra Clean In Place (UCIP)
- Solvent seal quench
- Flush Diaphragm Pressure Transducer — for electronic readings of the system pressure
- Explosion Proof Motor — for hazardous environments
- Alternate Finishes — to meet sanitary standards
- CE compliance (Europe)



M-210A Specifications

| | |
|--------------------------|---|
| Operating Pressure Range | 2,500 to 12,000 psi (170 to 810 bar) |
| Nominal Flow Rate | 1.0 to 1.5 GPM (3.8-5.7 lpm) depending on product characteristics |
| Sample Size | 1 gallon (4.0 liters) to continuous |
| Power Requirements | 3 phase electric service, 208/230/460V 15 hp (11 kW) |
| Utility Requirement | Cooling water for hydraulic oil heat exchanger and optional process product heat exchanger, compressed air [50-150 psi 1scfm (3.5-10 bar 28 slpm) @ 50 psi (3.4 bar), pressure dew point of 0-35°F(-17.7 to 1.6°C)] |
| Dimensions | (H x W x D) 56" x 72" x 34" (142 x 183 x 86 cm) |
| Weight | 1400 lbs. (635 kg) |

M-210B Specifications

| | |
|--------------------------|---|
| Operating Pressure Range | 4,000 to 18,000 psi (270 to 1200 bar) |
| Nominal Flow Rate | 0.5 to 0.6 GPM (1.9-2.3 lpm) depending on product characteristics |
| Sample Size | 1 gallon (4.0 liters) to continuous |
| Power Requirements | 3 phase electric service, 208/230/460V 15 hp (11 kW) |
| Utility Requirement | Cooling water for hydraulic oil heat exchanger and optional process product heat exchanger, compressed air [50-150 psi 1scfm (3.5-10 bar 28 slpm) @ 50 psi (3.4 bar), pressure dew point of 0-35°F(-17.6 to 1.6°C)] |
| Dimensions | (H x W x D) 56" x 72" x 34" (142 x 183 x 86 cm) |
| Weight | 1400 lbs. (635 kg) |

M-210C Specifications

| | |
|--------------------------|---|
| Operating Pressure Range | 6,000 to 30,000 psi (410 to 2100 bar) |
| Nominal Flow Rate | 0.33 to 0.43 GPM (1.2-1.6 lpm) depending on product characteristics |
| Sample Size | 1 gallon (4.0 liters) to continuous |
| Power Requirements | 3 phase electric service, 208/230/460V 15 hp (11 kW) |
| Utility Requirement | Cooling water for hydraulic oil heat exchanger and optional process product heat exchanger, compressed air [50-150 psi 1scfm (3.5-10 bar 28 slpm) @ 50 psi (3.4 bar), pressure dew point of 0-35°F(-17.6 to 1.6°C)] |
| Dimensions | (H x W x D) 56" x 72" x 34" (142 x 183 x 86 cm) |
| Weight | 1400 lbs. (635 kg) |



Microfluidics Morehouse-COWLES MEMBER OF MFIC CORPORATION

30 Ossipee Road, P.O. Box 9101
 Newton, MA 02464-9101 USA
 Tel: 1-800-370-5452 or: 617-969-5452
 Fax: 617-965-1213
 e-mail: mixinginfo@mfics.com
www.microfluidicscorp.com

European Office
 Edisonstr.15
 68623 Lampertheim, Germany
 Tel: +49 (0) 6206-503-700
 Fax: +49 (0) 6206-503-705