

MGS Tray Denesting

Tray Denesting: Separating,
Feeding and Placing of Stacked
and Nested Items.

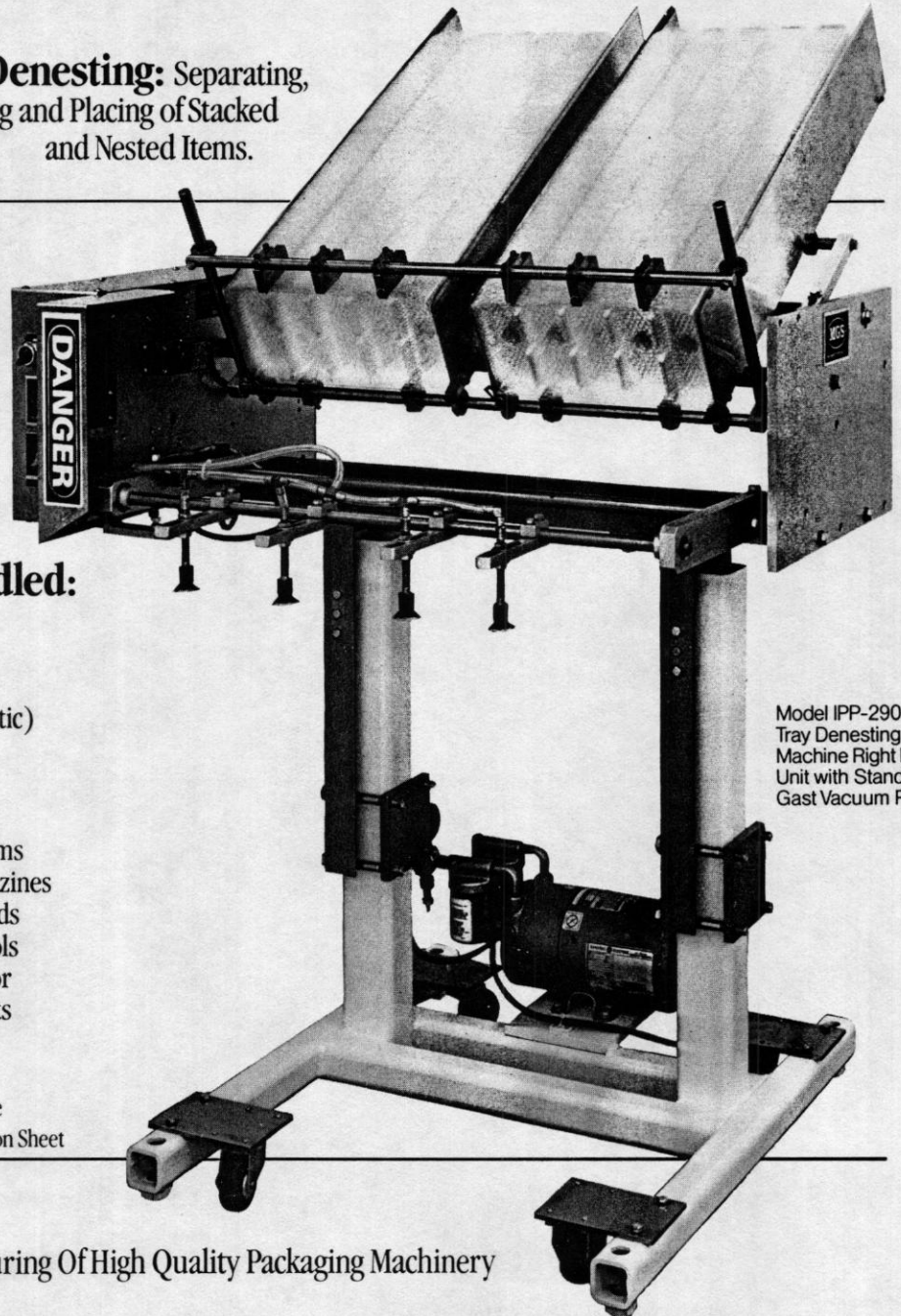

Trays Typically Handled:

Bakery
Candy
Meat/Poultry
TV Dinner (Foil, Pulp & Plastic)
Tubs (Plastic & Foil)

Options:

PIAB or Gast Vacuum Systems
ThumbWheel Adjustable Magazines
Quick Change Vacuum Heads
Downstream Surge Controls
Low Level Magazine Sensor
Various Actuated Clip Units

For Machine Specifications see
the Model "IPP D" Specification Sheet

Model IPP-290D
Tray Denesting
Machine Right Hand
Unit with Stand and
Gast Vacuum Pump

Leaders In The Manufacturing Of High Quality Packaging Machinery

MGS

MACHINE CORPORATION
9900 85th Avenue North
Minneapolis, MN 55369
(612) 425-8808

Packaging - Processing
Bid on Equipment

1-847-683-7720

www.bid-on-equipment.com

MGS Tray Denesting

C O N S T R U C T I O N T Y P E S :

SANITARY: Stainless Steel Drive Cover, Plated Steel, Anodized Aluminum with Painted Stand. Optional Stainless Steel Stand. NEMA 1/12 ELECTRICAL.

WASHDOWN: All Stainless Steel Construction Fabrication with Anodized Aluminum. NEMA 12/4 ELECTRICAL. Not all purchase parts are WASHDOWN.

NEMA 4X: All Stainless Steel Construction Fabrication, Hard Coated Aluminum. NEMA 4X ELECTRICAL. Not all purchase parts are WASHDOWN.

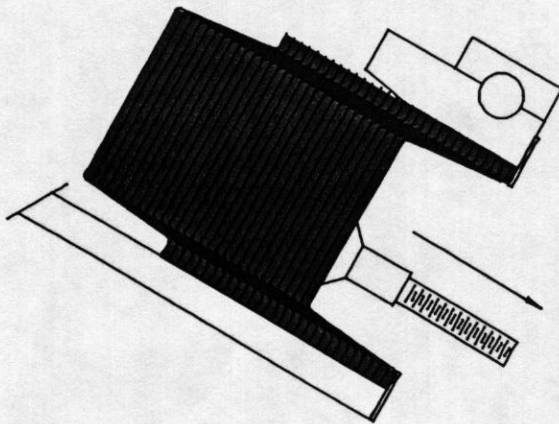

STANDARD PICK

STANDARD MOTION: Smooth, rigid bottom tray.

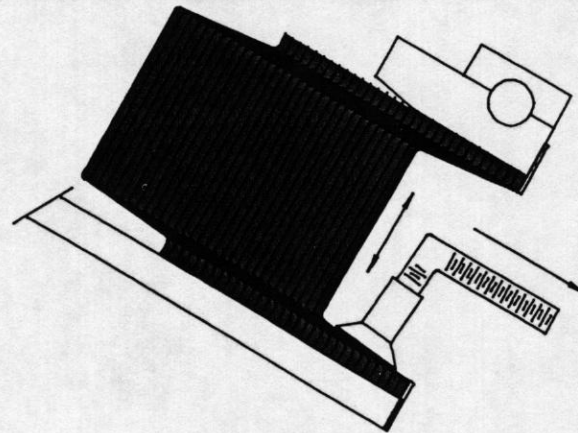

DENEST MOTION

DENEST MOTION: Smooth, rigid sidewall tray (bottom not smooth).

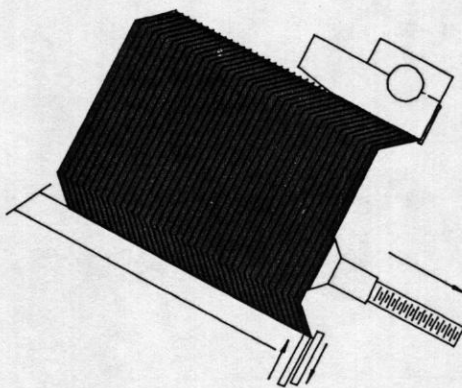

CLAMP & RELEASE

THICK/RIGID TRAY: Clamp and Release. Retractable front clip and clamp device for the second tray.

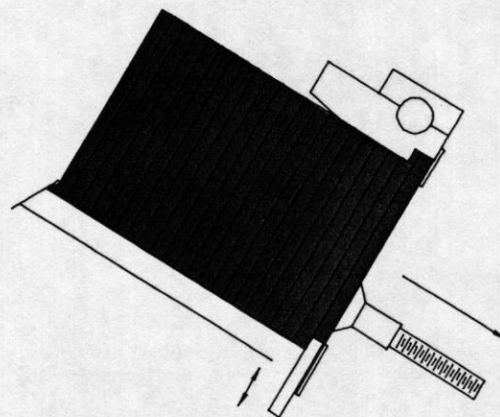

PUSH & PICK

UNIFORM RIGID: Push up and Pick. Bottom actuated blade to push over the bottom clip.

Packaging - Processing
Bid on Equipment

1-847-683-7720

www.bid-on-equipment.com



MACHINE CORPORATION
9900 85th Avenue North
Minneapolis, MN 55369
(612) 425-8808