

Packaging - Processing

Bid on Equipment

1-847-683-7720

www.bid-on-equipment.com

SideWinder™

O U T S E R T E R



Front View with 48" Long
Powered Magazine and 8'
Long Tabletop Conveyor

SPECIFICATIONS

FEATURES & BENEFITS:

- Versatile standard design allows the *SideWinder*™ to be supplied as a stand-alone machine, provided with a conveyor, or fit over an existing line.
- MGS' standard rotary motion is a proven design that creates a clean and simple picking motion and has years of field-tested experience.
- Clean GMP design eliminates the possibility of lost outserts in the machine and reduces time spent in outsert count validation.
- Easy-to-load horizontal powered magazine means a lower, more ergonomic magazine load height.
- Open station prior to outsert placement allows for additional functions, such as bar code scanning. This capability can greatly reduce waste and rework.
- Many options available such as various styles of bottle metering devices, allowing the end user to customize the machine to their specific needs.

SPECIFICATIONS

SideWinderTM O U T S E R T E R

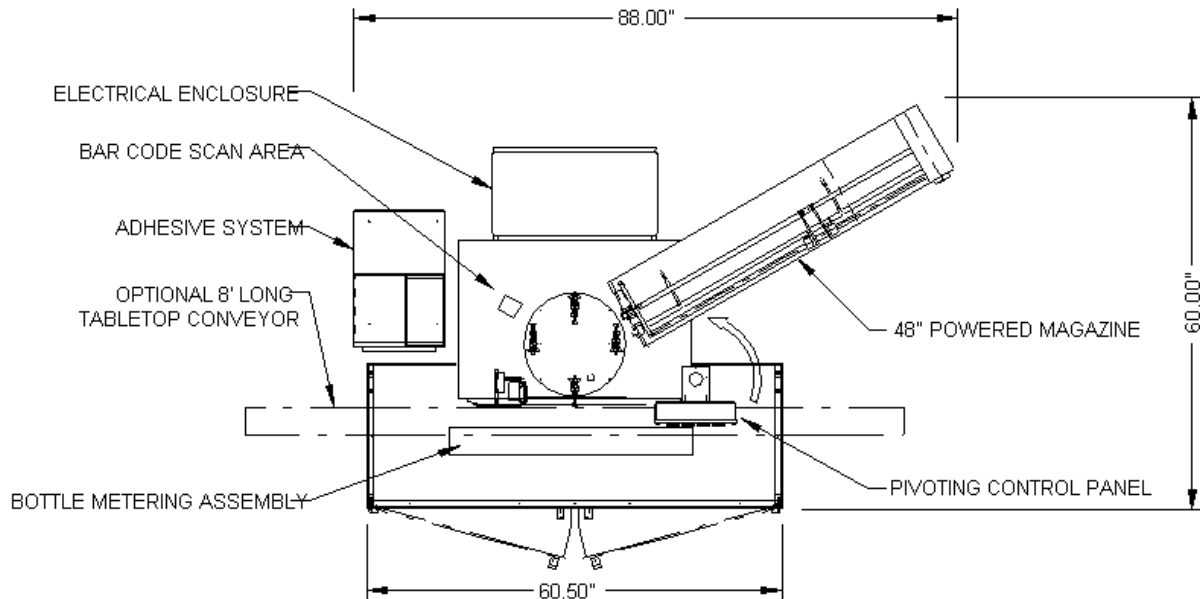

TYPICAL UTILITY REQUIREMENTS:

ELECTRICAL: 230 VAC, 3 Ph, 50/60 Hz
SideWinder: 15 Amps Max
Glue System: 17 Amps Max
AIR: 80 PSI Filter and Regulator Provided
VACUUM: Up To 10 SCFM At 20" HG
(if optional pump is not purchased)

MAXIMUM SPEEDS:

Up to 120 BPM Random Cycle Mode
Up to 250 BPM Continuous Mode

OPTIONS AVAILABLE:

- Machine Orientation
- Casters
- Powered Magazine – many lengths available
- Upstream/Downstream Surge Sensors
- Low Level Magazine Sensor
- No Product No Placement
- Tabletop Conveyor
- Missed Detection System with or without buzzer
- Timing Screw Indexer
- Bar Code Scanner
- Bottle Turning Modules
- Outsert Presence Detection
- Other Drive Options
- Product Reject Station with Reject Verification
- Venturi Vacuum System
- Rotary Vane Vacuum Pump
- Floor Stand
- Screw Height Adjustment

PRODUCT SIZE RANGE:

Outserts:

- Minimum: 1.13" L x 1.13" H x .03" Thick
- Maximum: 2.75" L x 4" H x .38" Thick

Target (Bottles or Cartons):

- Minimum: 1.25" A x 1.25" P x 2.63" H
- Maximum: 4" A x 4" P x 8" H

(A = Across Conveyor P = Parallel to Flow)



WE do it RIGHT

763.425.8808 ■ www.mgsmachine.com

Packaging - Processing
Bid on Equipment

1-847-683-7720

www.bid-on-equipment.com