

Packaging - Processing
Bid on Equipment

1-847-683-7720

www.bid-on-equipment.com

Carton Forming Machines

MGS

MACHINE CORPORATION

Glue Style Plunge Forming



Model CFG-100
Without Discharge Conveyor

FEATURES:

- Small Size
- Cam Controlled Short Stroke Forming Head
- Carton Magazine 40" Above the floor
- PLC and Encoder Controls
- Positive Vacuum Carton Stripper
- Angled Feed and Forming Design
- Shuttle Blank Transfer
- Low Friction Material, Female Cavity
- Screw Adjustments



Materials

Typically Handled

Four Corner Tray

Tri-Seal Carton

Open Top Carton

Flip Top Carton

Packaging - Processing
Bid on Equipment

1-847-683-7720

www.bid-on-equipment.com

Specifications

OPTIONS AVAILABLE

- SCR Variable Speed Drive
- Detented Overload Clutch
- Clutch & Brake Cycle Control
- Discharge Conveyors
 - Belt or Lugged
 - Inline or Right Angle
- Message Display
- Low Magazine Sensor
- Downstream Surge Sensor
- Glue System PMI Interlock
- Casters

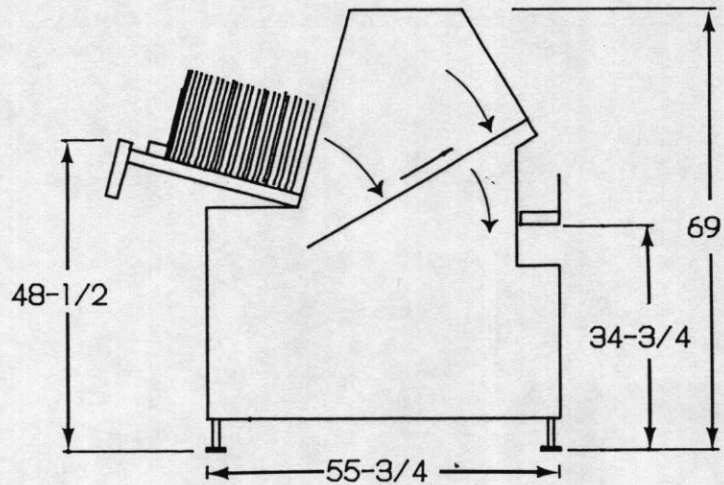

Typical Power Requirements

230/460 VAC 3 Phase 60 Hz

115 VAC 1 Phase 60 Hz

6 KVA (approx)

Air: Less than 3.0 CFM @ 80 PSIG

 OPERATOR STATION

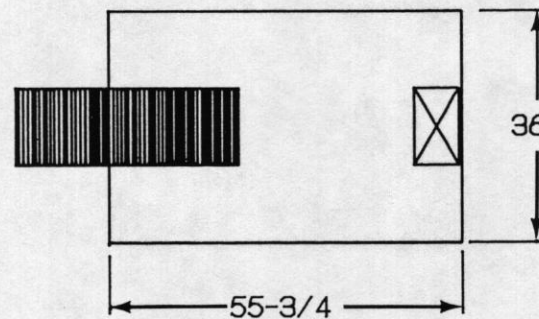
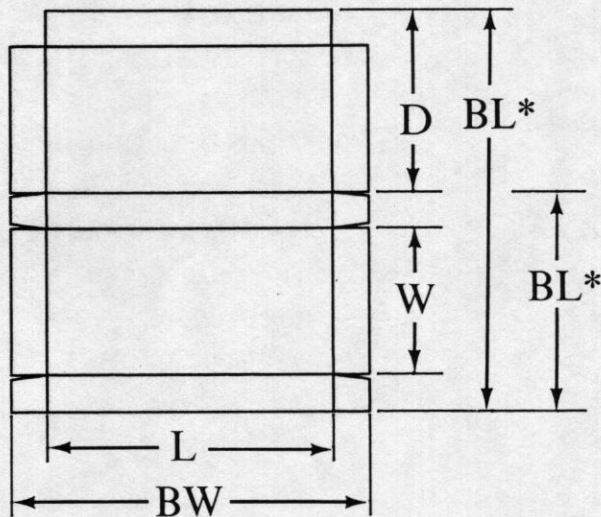

CARTON SIZE RANGE					
	L	W	D	BW	BL*
Minimum	6"	3.5"	0.75"	7.5"	5"
Maximum	16.5"	17"	3.5"	18"	18.5"

BL* This dimension applies with or without cover.

LEADERS IN THE MANUFACTURING OF HIGH QUALITY PACKAGING MACHINERY

MGS

MACHINE CORPORATION

9900 85th AVENUE NORTH

MINNEAPOLIS, MN 55369

(612) 425-8805